

fi-6140/fi-6240
fi-6130/fi-6230
Image Scanner
fi-614PR, Imprinter
Maintenance Manual



						TITLE	fi-6140/fi-6240/fi-6130/fi-6230/fi-614PR Maintenance Manual		
08	July 27, 09	K.Okada	A.Miyoshi	I.Fujioka	Refer to Revision Record on page 2.	DRAW No.	P1PA03540-B0XX/6	CUST.	
07	Nov.12, 08	K.Okada	T.Anzai	I.Fujioka	Refer to Revision Record on page 2.				
06	Mar.10, 08	K.Okada	T.Anzai	I.Fujioka	Refer to Revision Record on page 2.				
Rev.	DATE	DESIGN	CHECK	APPR.	DESCRIPTION	PFU LIMITED		Page	1 /257
Design	July 27, 2007	K.Okada	CHECK	K.Okada		APPR.	T.Anzai		

Revision Record		
Edition	Date published	Revised contents
01	July 27, 2007	First version released
02	August 31, 2007	47, 48: Error Recovery Guide messages added. 77, 106-107, 114: Replacement procedure changed.
03	September 20, 2007	78, 122, 128, 171: Photos changed. 93: Reference step changed.
04	November 14, 2007	fi-6130/fi-6230/fi-614PR added. P30, 44: Maintenance parts numbers revised.
05	December 18, 2007	P12, 13: Specification revised. Chapter 5 and Section 8-6: Screw classification added. P110: Tension when the spring balance touches the rib revised. P226: Tips for removing the inner cover added. P233-234: LF Motor belt tension adjustment procedure revised. P253-254: Screw specifications added.
06	March 10, 2008	P49, 68: "J0" error added.
07	November 12, 2008	Section 1-1-2: Minimum document (A8) size changed. Section 4-3-11: Procedures on "Vertical straight streaks appear in scanned image" added. Section 5-3-4: Procedure for cleaning "Glass inside of Flatbed" changed. Appendix 2: Emulation mode" added.
08	July 27, 2009	Section 4-3-23 (P61): Troubleshooting for "F4: Background changeover unit alarm" revised. Section 5-9-5 (P95): Notes on US Sensor FX installation added. Section 6-1, 6-1-5 (P156, 167): Notes on Maintenance mode (white level adjustment) added.

The contents of this manual are subject to change without prior notice.

All rights reserved. Copyright© PFU LIMITED 2007-2009

						TITLE	fi-6140/fi-6240/fi-6130/fi-6230/fi-614PR Maintenance Manual			
08	July 27, 09	K.Okada	A.Miyoshi	I.Fujioka	Refer to Revision Record on page 2.	DRAW No.	P1PA03540-B0XX/6	Page	2/257	
07	Nov.12, 08	K.Okada	T.Anzai	I.Fujioka	Refer to Revision Record on page 2.					CUST.
06	Mar.10, 08	K.Okada	T.Anzai	I.Fujioka	Refer to Revision Record on page 2.					
Rev.	DATE	DESIGN	CHECK	APPR.	DESCRIPTION	PFU LIMITED				
Design	July 27, 2007	K.Okada	CHECK	K.Okada		APPR.	T.Anzai			

Trademarks

Microsoft, Windows, and Windows NT are registered trademarks of Microsoft Corporation in the United States and/or other countries.

ISIS, QuickScan and their respective logos are trademarks or registered trademarks of Pixel Translations, a division of Captiva Software Corporation in the United States.

Adobe, the Adobe logo, and Acrobat are either registered trademarks of Adobe Systems Incorporated in the United States and/or other countries.

Other product names are the trademarks or registered trademarks of the respective companies.

How Trademarks are Indicated in This Manual

References to operating systems (OS) and applications are indicated as follows:

Windows 2000: Microsoft® Windows® 2000 Professional operating system.

Windows XP: Microsoft® Windows® XP Professional operating system (32-bit/64-bit)
 Microsoft® Windows® XP Home Edition operating system.

Windows Server2003: Microsoft® Windows Server™ 2003 Standard Edition operating system (32-bit/64-bit)

Windows Vista: Microsoft® Windows Vista™ Home Basic operating system (32-bit/64-bit)
 Microsoft® Windows Vista™ Home Premium operating system (32-bit/64-bit)
 Microsoft® Windows Vista™ Business operating system (32-bit/64-bit)
 Microsoft® Windows Vista™ Enterprise operating system (32-bit/64-bit)
 Microsoft® Windows Vista™ Ultimate operating system (32-bit/64-bit)

Where there is no distinction between the different versions of the above operating system, the general term “Windows” is used.

						TITLE	fi-6140/fi-6240/fi-6130/fi-6230/fi-614PR Maintenance Manual		
08	July 27, 09	K.Okada	A.Miyoshi	I.Fujioka	Refer to Revision Record on page 2.	DRAW No.	P1PA03540-B0XX/6	CUST.	
07	Nov.12, 08	K.Okada	T.Anzai	I.Fujioka	Refer to Revision Record on page 2.				
06	Mar.10, 08	K.Okada	T.Anzai	I.Fujioka	Refer to Revision Record on page 2.				
Rev.	DATE	DESIGN	CHECK	APPR.	DESCRIPTION	PFU LIMITED		Page	4/257
Design	July 27, 2007	K.Okada	CHECK	K.Okada		APPR.	T.Anzai		

Contents

Chapter 1 Overview	10
1-1 Specification.....	10
1-1-1 Features	10
1-1-2 Scanner Specifications.....	11
1-1-3 Environmental Specifications	12
1-1-4 Appearance.....	13
1-1-5 Outer Dimensions	16
1-1-6 Document Specifications.....	17
1-1-7 Multi feed Detection Condition	18
1-2 Scanner Configuration	19
1-2-1 ADF Unit.....	19
1-2-2 Reading Station	20
1-2-3 Controller	22
1-2-4 Electric Component Block Diagram.....	24
Chapter 2 Description of Scanner Operation	25
2-1 Unpacking the scanner	25
2-2 Installing the scanner	27
2-2-1 For safety installation	27
2-2-2 Installation.....	27
Chapter 3 Maintenance Parts	29
3-1 BASE UNIT.....	31
3-2 BASE ASSY	31
3-3 INVERTER.....	32
3-4 LAMP	32
3-5 US SENSOR FX (Multifeed detection)	33
3-6 OPT UNIT	33
3-7 BW MOTOR.....	34
3-8 GUIDE P ASSY (Sheet Guide)	34
3-9 PICK MOTOR ASSY	35
3-10 PICK MOTOR	35
3-11 PICK SHAFT ASSY.....	36
3-12 SWITCH (ADF open detection)	36
3-13 UPPER UNIT.....	37
3-14 UPPER ASSY	37
3-15 ADF MOTOR	38
3-16 (Reserved).....	38
3-17 (Reserved).....	38
3-18 (Reserved).....	38
3-19 US SENSOR RV (Multifeed detection).....	38
3-20 SENSOR EMP (Paper empty detection).....	39
3-21 PANEL PCA.....	39
3-22 BR SHAFT ASSY	39
3-23 CONTROL PCA	40
3-24 (Reserved).....	41
3-25 STACKER UNIT	41
3-26 CHUTER UNIT (ADF paper chute).....	41
3-27 AC ADAPTER.....	42
3-28 AC CORDSETS.....	42

						TITLE	fi-6140/fi-6240/fi-6130/fi-6230/fi-614PR Maintenance Manual		
08	July 27, 09	K.Okada	A.Miyoshi	I.Fujioka	Refer to Revision Record on page 2.	DRAW	P1PA03540-B0XX/6	CUST.	
07	Nov.12, 08	K.Okada	T.Anzai	I.Fujioka	Refer to Revision Record on page 2.	No.			
06	Mar.10, 08	K.Okada	T.Anzai	I.Fujioka	Refer to Revision Record on page 2.				
Rev.	DATE	DESIGN	CHECK	APPR.	DESCRIPTION	PFU LIMITED		Page	5/257
Design	July 27, 2007	K.Okada	CHECK	K.Okada		APPR.	T.Anzai		

3-29	USB CABLE.....	42
3-30	FB TOP COVER.....	43
3-31	FB MOTOR UNIT.....	43
3-32	FB MOTOR.....	44
3-33	OPT BOX UNIT.....	44
3-34	(Reserved).....	44
3-35	(Reserved).....	44
3-36	(Reserved).....	44
3-37	CR CABLE.....	45
3-38	DOC COVER ASSY.....	45
3-39	JOINT PCA.....	46
6-40	(Reserved).....	46

Chapter 4 Troubleshooting..... 47

4-1	Operation Panel Sequence at Power-on.....	47
4-2	Temporary errors and Alarm detection algorithm.....	48
4-2-1	Temporary errors.....	48
4-2-2	Alarms.....	48
4-2-3	Error Recovery Guide.....	48
4-3	Troubleshooting.....	49
4-3-1	Scanner is not turned ON (Display of the operator panel goes out).....	51
4-3-2	Scanning does not start.....	51
4-3-3	Scanned image is distorted.....	51
4-3-4	Resolution is not satisfactory or tone error is too large.....	52
4-3-5	Too much jitter on scanned image with FB scanning fi-6240/fi-6230	52
4-3-6	Scanned image is misaligned with FB scanning fi-6240/fi-6230	53
4-3-7	Scan magnification factor abnormal with FB scanning fi-6240/fi-6230	53
4-3-8	Too much jitter on scanned image with ADF scanning.....	54
4-3-9	Scanned image is misaligned with ADF scanning.....	55
4-3-10	Scan magnification factor abnormal with ADF scanning.....	55
4-3-11	Vertical streaks appear in scanned image.....	56
4-3-12	When calibrating white of scanned image.....	56
4-3-13	Frequent “J1: paper jam” error at scanner section.....	57
4-3-14	Frequent “J2: multi feed error”.....	58
4-3-15	Error detection of “U4: Scanner Cover open”.....	58
4-3-16	Error detection of “No paper on the ADF paper chute (Chuter Unit)”.....	58
4-3-17	Frequent “U0: Shipping lock error” or “E0: Carrier drive alarm”.....	59
4-3-18	“E1/E2/E3: Optical alarm”.....	59
4-3-19	“E6: Operator panel alarm”.....	60
4-3-20	“E7: EEPROM alarm”.....	60
4-3-21	“E8: SCSI alarm”.....	60
4-3-22	“E9: Image memory alarm”.....	60
4-3-23	“F4: Background changeover unit alarm”.....	61
4-3-24	“C0: LSI alarm”.....	61
4-3-25	“H0/H8: Motor alarm”.....	62
4-3-26	“Lamp alarm”.....	63
4-3-27	“L6: US sensor alarm”.....	63
4-3-28	“F: ROM sum check alarm”.....	63
4-3-29	Driver error.....	63
4-3-30	“Abnormal command”.....	64
4-3-31	“Interface alarm”.....	64
4-3-32	Frequent “J1: paper jam” error at Imprinter (with Imprinter installed) fi-6140/fi-6130	64
4-3-33	Error detection of “U5:Imprinter cover open” (with Imprinter installed) fi-6140/fi-6130	64
4-3-34	Imprinter does not initially operate (with Imprinter installed) fi-6140/fi-6130	65
4-3-35	“U6: No print cartridge” (with Imprinter installed) fi-6140/fi-6130	65

						TITLE	fi-6140/fi-6240/fi-6130/fi-6230/fi-614PR Maintenance Manual		
08	July 27, 09	K.Okada	A.Miyoshi	I.Fujioka	Refer to Revision Record on page 2.	DRAW No.	P1PA03540-B0XX/6	Page	6/257
07	Nov.12, 08	K.Okada	T.Anzai	I.Fujioka	Refer to Revision Record on page 2.				
06	Mar.10, 08	K.Okada	T.Anzai	I.Fujioka	Refer to Revision Record on page 2.				
Rev.	DATE	DESIGN	CHECK	APPR.	DESCRIPTION	PFU LIMITED			
Design	July 27, 2007	K.Okada	CHECK	K.Okada		APPR.	T.Anzai		

4-3-36	“H6: Imprinter fuse blown” (with Imprinter installed)	fi-6140/fi-6130	66
4-3-37	“A0: Imprinter control board alarm” (with Imprinter installed)	fi-6140/fi-6130	66
	“A1: Imprinter communication timeout” (with Imprinter installed)	fi-6140/fi-6130	66
	“A2: Ink head alarm” (with Imprinter installed)	fi-6140/fi-6130	66
	“A3: Imprinter EEPROM alarm” (with Imprinter installed)	fi-6140/fi-6130	66
	“A4: Imprinter ROM alarm” (with Imprinter installed)	fi-6140/fi-6130	66
4-3-38	No printing / Printed letters are distorted (with Imprinter installed)	fi-6140/fi-6130	67
4-3-39	Print form is dirty (with Imprinter installed)	fi-6140/fi-6130	67
4-3-40	Printing is interrupted in process (with Imprinter installed)	fi-6140/fi-6130	67
4-3-41	Frequent “J0: paper jam” (paper protection function)	fi-6140/fi-6240	68

Chapter 5 Disassembly/Assembly 69

5-1	For the safety operation	69
5-2	Periodic Maintenance	70
5-3	Cleaning	71
5-3-1	OPT Unit (common to ADF front/backside and Flatbed)	71
5-3-2	Glass inside of Base Unit	71
5-3-3	Glass inside of Upper Unit	71
5-3-4	Glass inside of Flatbed	fi-6240/fi-6230
5-3-5	White reference inside of Base Unit	72
5-3-6	White reference inside of Upper Unit	72
5-4	Maintenance tool	73
5-5	Parts that should not be Disassembled	74
5-6	(Reserved)	74
5-7	Removing Flatbed	fi-6240/fi-6230
5-8	Chuter Unit (ADF Paper Chute), Stacker Unit	77
5-8-1	Chuter Unit (ADF Paper Chute)	77
5-8-2	Stacker Unit	fi-6140/fi-6130
5-9	Base Unit	79
5-9-1	Base Unit	79
5-9-2	Base ASSY	84
5-9-3	Inverter (for front side scanning)	85
5-9-4	Lamp (for front side scanning)	87
5-9-5	US Sensor FX (Multifeed detection)	93
5-9-6	OPT Unit (for front side scanning)	96
5-9-7	BW Motor	98
5-9-8	Guide P ASSY (Sheet Guide)	100
5-9-9	PICK Motor ASSY	101
5-9-10	PICK Motor	103
5-9-11	PICK Shaft ASSY	105
5-9-12	Switch (ADF open detection)	106
5-10	Upper Unit	107
5-10-1	Upper Unit	107
5-10-2	Upper ASSY	108
5-10-3	ADF Motor	109
5-10-4	OPT Unit (for backside scanning)	112
5-10-5	Inverter (for backside scanning)	114
5-10-6	Lamp (for backside scanning)	116
5-10-7	US Sensor RV (Multifeed detection)	123
5-10-8	Sensor EMP (Paper empty detection)	124
5-10-9	Panel PCA	125
5-10-10	BR Shaft ASSY	127
5-10-11	Top Cover	128
5-11	Control PCA	130

						TITLE	fi-6140/fi-6240/fi-6130/fi-6230/fi-614PR Maintenance Manual		
08	July 27, 09	K.Okada	A.Miyoshi	I.Fujioka	Refer to Revision Record on page 2.	DRAW	P1PA03540-B0XX/6	CUST.	
07	Nov.12, 08	K.Okada	T.Anzai	I.Fujioka	Refer to Revision Record on page 2.	No.			
06	Mar.10, 08	K.Okada	T.Anzai	I.Fujioka	Refer to Revision Record on page 2.				
Rev.	DATE	DESIGN	CHECK	APPR.	DESCRIPTION	PFU LIMITED		Page	7/257
Design	July 27, 2007	K.Okada	CHECK	K.Okada		APPR.	T.Anzai		

5-12	Flatbed	133
5-12-1	FB Top Cover	fi-6240/fi-6230	133
5-12-2	FB Motor Unit	fi-6240/fi-6230	134
5-12-3	FB Motor	fi-6240/fi-6230	138
5-12-4	OPT Box Unit	fi-6240/fi-6230	140
5-12-5	OPT Unit	fi-6240/fi-6230	143
5-12-6	Inverter	fi-6240/fi-6230	145
5-12-7	Lamp	fi-6240/fi-6230	147
5-12-8	CR Cable	fi-6240/fi-6230	150
5-12-9	Document Cover	fi-6240/fi-6230	153
5-12-10	Joint PCA	fi-6240/fi-6230	154
Chapter 6 Adjustment/Settings			156
6-1	Maintenance mode	156
6-1-1	Activating the Maintenance mode	156
6-1-2	Maintenance mode #1: Paper feeding / Sensor / Background changeover test	158
6-1-3	Maintenance mode #2: Main scanning / Sub-scanning magnification adjustment	160
6-1-4	Maintenance mode #3: Offset adjustment	164
6-1-5	Maintenance mode #4: White level adjustment	167
6-1-6	Maintenance mode #5: Consumable counter display and reset	170
6-1-7	Maintenance mode #6: Miscellaneous information display	172
6-1-8	Maintenance mode #7: EEPROM data restore	174
6-2	Saving EEPROM data	175
Chapter 7 Basic Operation and Daily Care			177
7-1	Basic Operation	177
7-1-1	Turn ON/OFF the Scanner	177
7-1-2	Loading Documents on the ADF for Scanning	178
7-1-3	Loading Documents on the Flatbed for Scanning	fi-6240/fi-6230	181
7-2	Daily Care	182
7-2-1	Cleaning the ADF	182
7-2-2	Cleaning the Flatbed	fi-6240/fi-6230	185
7-3	Replacing the consumables	186
7-3-1	Consumables	186
7-3-2	Checking and Resetting the Consumables Counters	187
7-3-3	Brake roller replacement	189
7-3-4	Pick roller replacement	191
Chapter 8 Imprinter (Optional)			194
8-1	Imprinter Specifications	194
8-1-1	Printing Functions	194
8-1-2	Environmental Specifications	195
8-1-3	Appearance	196
8-1	Imprinter Operation	198
8-2-1	Imprinter Operation	198
8-2-2	Circuit Block Diagram	199
8-3	Unpacking and Installation of Imprinter	200
8-3-1	Unpacking the Imprinter	200
8-3-2	Installing the Imprinter	201
8-3-3	Loading the Print cartridge	203
8-3-4	Operation Test	205
8-4	Maintenance Parts for the Imprinter	206
8-4-1	SENSOR	207
8-4-2	IMP CT	207
8-4-3	IMP JNT	208

						TITLE	fi-6140/fi-6240/fi-6130/fi-6230/fi-614PR Maintenance Manual		
08	July 27, 09	K.Okada	A.Miyoshi	I.Fujioka	Refer to Revision Record on page 2.	DRAW	P1PA03540-B0XX/6	CUST.	
07	Nov.12, 08	K.Okada	T.Anzai	I.Fujioka	Refer to Revision Record on page 2.	No.			
06	Mar.10, 08	K.Okada	T.Anzai	I.Fujioka	Refer to Revision Record on page 2.				
Rev.	DATE	DESIGN	CHECK	APPR.	DESCRIPTION	PFU LIMITED		Page	8/257
Design	July 27, 2007	K.Okada	CHECK	K.Okada		APPR.	T.Anzai		

8-4-4	PR HARNESS.....	208
8-4-5	IM FELT	209
8-4-6	LF MOTOR	209
8-4-7	IM HOLDER ASSY3	210
8-4-8	IM HOLD LEVER3	210
8-4-9	FPC CABLE	211
8-4-10	IM PINCH ASSY3.....	211
8-4-11	IM LOCK LEVER.....	212
8-4-12	SWITCH (Cover open detection).....	212
8-4-13	GUIDE SHEET.....	213
8-4-14	PAPER GUIDE3.....	213
8-5	Troubleshooting.....	214
8-6	Disassembly/Assembly.....	215
8-6-1	For Safety operation.....	215
8-6-2	Maintenance tool.....	215
8-6-3	(Reserved).....	215
8-6-4	Removing Imprinter	216
8-6-5	IM HOLD LEVER3	217
8-6-6	IM PINCH ASSY3.....	218
8-6-7	IMP JNT.....	221
8-6-8	IM HOLDER ASSY3/FPC CABLE	223
8-6-9	IMP CT	225
8-6-10	SENSOR	227
8-6-11	SWITCH (Cover open detection).....	230
8-6-12	LF MOTOR.....	232
8-6-13	PR HARNESS.....	235
8-6-14	IM FELT	236
8-6-15	IM LOCK LEVER	238
8-6-16	GUIDE SHEET	239
8-7	Adjustment/Settings.....	240
8-8	Basic Operation and Daily Care of the Imprinter	241
8-8-1	Setting The Print Position	241
8-8-2	How to Use the Paper Guides.....	242
8-8-3	Print Setup.....	244
8-8-4	Removing Jammed Documents.....	247
8-9	Cleaning and Consumables.....	248
8-9-1	Cleaning the Print Cartridge.....	248
8-9-2	Cleaning the Imprinter	249
8-9-3	Cleaning the Imprinter Rollers	250
8-9-4	Replacing the Print Cartridge.....	251
Appendix 1 Screws		253
Appendix 2 Emulation Mode		255

						TITLE	fi-6140/fi-6240/fi-6130/fi-6230/fi-614PR Maintenance Manual		
08	July 27, 09	K.Okada	A.Miyoshi	I.Fujioka	Refer to Revision Record on page 2.	DRAW No.	P1PA03540-B0XX/6	CUST.	
07	Nov.12, 08	K.Okada	T.Anzai	I.Fujioka	Refer to Revision Record on page 2.				
06	Mar.10, 08	K.Okada	T.Anzai	I.Fujioka	Refer to Revision Record on page 2.				
Rev.	DATE	DESIGN	CHECK	APPR.	DESCRIPTION	PFU LIMITED		Page	9/257
Design	July 27, 2007	K.Okada	CHECK	K.Okada		APPR.	T.Anzai		

Chapter 1 Overview

1-1 Specification

1-1-1 Features

The fi-6140/fi-6240/fi-6130/fi-6230 (hereinafter called “the scanner”) offers high-speed color/gray/monochrome scanning with 600 dpi of optical resolution, up to A4 size (Legal size for ADF). It supports two interfaces, SCSI interface and USB interface, either of which can be used at a time.

The following points have been improved for the scanner compared to the previous type (fi-5120C/fi-5220C).

- (1) Improvement of color scanning speed
By changing the CCD, color scanning speed (A4 Portrait 300dpi) is improved from 30 ppm to 40 ppm.
- (2) Ultrasonic multi feed sensor
As with the previous model, the scanner introduces ultrasonic sensor in order to perform very reliable multi feed detection.
- (3) Prevention of image chipping at overscan

Increasing the number of CCD pixels enables to extend overscan width, so that the image will not be chipped even when the document is skewed.

- (4) Thicker card transportation
Feeding thick cards up to 1.4mm thick (including emboss) is available by improving the ADF transportation path.
- (5) Specified number of scanned pages ejected to the stacker
Pre-pick is operable when the number of documents to be scanned is specified.

fi-6140/fi-6130

An exclusive imprinter (fi-614PR, option) can be installed under fi-6140/fi-6130 as shown in the photo below. See Chapter 8 for the details of the imprinter.



Rev.	DATE	DESIGN	CHECK	APPR.	DESCRIPTION	TITLE				
08	July 27, 09	K.Okada	A.Miyoshi	I.Fujioka	Refer to Revision Record on page 2.	fi-6140/fi-6240/fi-6130/fi-6230/fi-614PR Maintenance Manual				
07	Nov.12, 08	K.Okada	T.Anzai	I.Fujioka	Refer to Revision Record on page 2.	DRAW No.	P1PA03540-B0XX/6	CUST.		
06	Mar.10, 08	K.Okada	T.Anzai	I.Fujioka	Refer to Revision Record on page 2.					
Design	July 27, 2007	K.Okada	CHECK	K.Okada		APPR.	T.Anzai	PFU LIMITED	Page	10 / 257

1-1-2 Scanner Specifications

No.	Items	Specifications				
		fi-6140	fi-6130	fi-6240	fi-6230	
1	Operating method	Automatic Document Feeder (ADF)		Automatic Document Feeder (ADF) and Flatbed (FB)		
2	Optical resolution	600 dpi				
3	Output resolution	Binary: 50 – 600dpi (unit: 1dpi), 1200dpi (by driver) Gray: 50 – 600 dpi (unit: 1dpi), 1200dpi (by driver) Color: 50 – 600 dpi (unit: 1dpi), 1200dpi (by driver)				
4	Bit depth	Color 24 bit/pixel, 8 bit/pixel (by driver), 4 bit/pixel (by driver) Gray 8 bit/pixel, 4 bit/pixel (by driver) Binary 1 bit				
5	Scanning speed (Engine speed) @A4, 200dpi	Binary	Simplex/Duplex	Simplex/Duplex	Simplex/Duplex	Simplex/Duplex
		Color	60 ppm / 120 ipm	40 ppm / 80 ipm	60 ppm / 120 ipm	40 ppm / 80 ipm
			40 ppm / 80 ipm	30 ppm / 60 ipm	40 ppm / 80 ipm	30 ppm / 60 ipm
6	Document size	Max: A4 (210 x 297 mm) or Legal (216 x 355.6 mm / 8.50 x 14 in.) Up to 3045 3048 mm (120 in.) of long page scanning is available. Min: A8 (52 52 x 74 mm) Portrait / Landscape				
7	Paper weight	0.05 ~ 0.26 mm (41 ~ 210 g/m ² , 9.4 ~ 56 lbs) A8 size: 0.15 ~ 0.26 mm (127 ~ 210 g/m ²)				
8	Card transport	Available, Portrait/Landscape feeding, Continuous feeding (up to 3 sheets of continuous feeding) Thickness: 1.4mm or less (fi-6140/fi-6240 models: Monochrome, 200dpi or smaller, Landscape, Card thickness: 1.25mm or smaller)				
9	Capacity of ADF	50 sheets @ A4, 80g/m ² or 20lb				
10	Background	Selectable (black or white)				
11	Multi feed detection	Ultrasonic sensor and paper detection sensor Document overlapping and document length detection				
12	Document size	---		Maximum: 216 x 297mm / 8.5 x 11.7 in.		
13	Scanning time	---		Binary/Gray/Color: approx.1.7 sec. @A4 Portrait, 200dpi		
14	background	---		White (Option: black)		
15	Scanning sensor	Color CCD x 2		Color CCD x 3		
16	Light source	White cold cathode discharge lamp x2		White cold cathode discharge lamp x3		
17	Interface	Ultra SCSI (x1) USB 2.0 (x1)	USB 2.0 (x1)	Ultra SCSI (x1) USB 2.0 (x1)	USB 2.0 (x1)	
18	Image memory	256 MB	64 MB	256 MB	64 MB	
19	Attached driver	FJ TWAIN / ISIS, ScandAll PRO, Adobe Acrobat, QuickScan Pro.Demo (Trial), Image processing software option (Trial)				
20	Operator panel	Buttons: Function, Send to, Scan/Stop, Power Lamps: Check LED, Power LED, Scanner status (Function No. Display)				
21	Supported Options	fi-614PR Imprinter		Black document pad		

Rev.	DATE	DESIGN	CHECK	APPR.	DESCRIPTION	TITLE			
08	July 27, 09	K.Okada	A.Miyoshi	I.Fujioka	Refer to Revision Record on page 2.	fi-6140/fi-6240/fi-6130/fi-6230/fi-614PR Maintenance Manual			
07	Nov.12, 08	K.Okada	T.Anzai	I.Fujioka	Refer to Revision Record on page 2.		DRAW No.	P1PA03540-B0XX/6	CUST.
06	Mar.10, 08	K.Okada	T.Anzai	I.Fujioka	Refer to Revision Record on page 2.				
Design	July 27, 2007	K.Okada	CHECK	K.Okada	APPR.	T.Anzai	PFU LIMITED	Page	11 / 257

1-1-3 Environmental Specifications

No.	Items		Specifications			
			fi-6140	fi-6130	fi-6240	fi-6230
1	Input power	Voltage	100 to 240V			
		Frequency	50/60 Hz			
2	Power consumption (Rated power)		42 W or less	38 W or less	50 W or less	45W or less
3	Noise		50 dB or less (excluding operator's area)			
4	Outer dimensions (Without ADF paper Chute and Stacker Unit)		301 (W) x 160 (D) x 158 (H) mm 11.8 (W) x 6.3 (D) x 6.2 (H) inch		301 (W) x 567 (D) x 229 (H) mm 11.8 (W) x 22.3 (D) x 9.0 (H) inch	
			Weight		4.2kg (9.3 lb)	
6	Ambient condition	Temperature	5 to 35 °C / 41 to 95 °F (Operating) -20 to 60 °C / -4 to 140 °F (Not operating)			
		Humidity	20 to 80 % (Operating)		8 to 95 % (Not operating)	
7	Calorific value	05	36.2 kcal/H or less	37.7 kcal/H or less	43.0 kcal/H or less	38.7 kcal/H or less
8	Weight at shipping		6.5 kg		13.0 kg	

						TITLE	fi-6140/fi-6240/fi-6130/fi-6230/fi-614PR Maintenance Manual		
08	July 27, 09	K.Okada	A.Miyoshi	I.Fujioka	Refer to Revision Record on page 2.	DRAW No.	P1PA03540-B0XX/6	CUST.	
07	Nov.12, 08	K.Okada	T.Anzai	I.Fujioka	Refer to Revision Record on page 2.				
06	Mar.10, 08	K.Okada	T.Anzai	I.Fujioka	Refer to Revision Record on page 2.				
Rev.	DATE	DESIGN	CHECK	APPR.	DESCRIPTION	PFU LIMITED		Page	12 / 257
Design	July 27, 2007	K.Okada	CHECK	K.Okada		APPR.	T.Anzai		

1-1-4 Appearance

[Front]

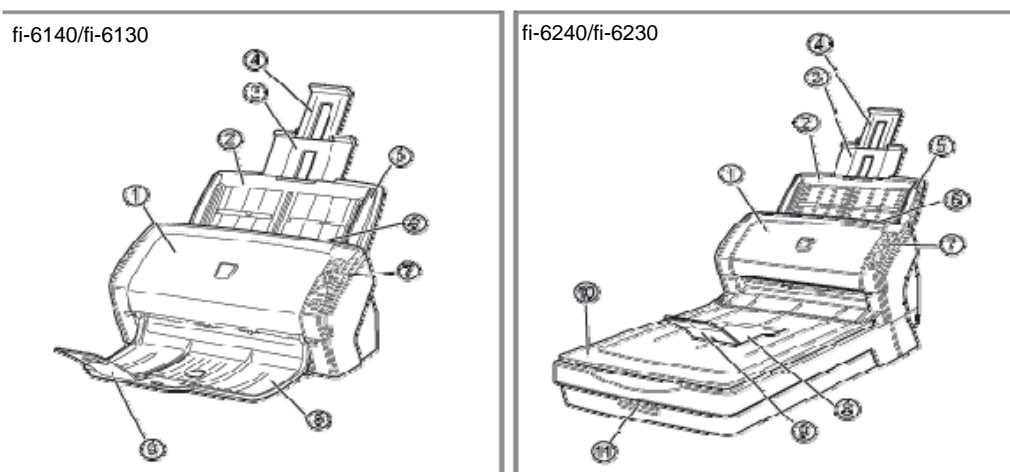

No.	Parts name	Function
1	ADF (Automatic Document Feeder)	Transports the documents to the reading position automatically.
2	ADF Paper Chute (Chute Unit)	Holds in place the document pages / sheets that are fed into the ADF.
3	Paper chute extension 1	
4	Paper chute extension 2	
5	Side Guide	Adjusted to the width of the paper in order not to scan skewed pages.
6	ADF open lever	Pull this lever toward you to open the ADF.
7	Operator Panel	This panel consists of a Function No. Display, four operating push buttons, and a LED.
8	Stacker	Scanned documents are ejected from the ADF onto this stacker.
9	Stacker extension	
10	Flatbed (FB) [fi-6240/fi-6230 only]	Place documents on the glass sheet by sheet for single-sheet scanning.
11	Transport lock switch [fi-6240/fi-6230 only]	Used to lock the carrier unit inside the flatbed during transportation.

[Inside]

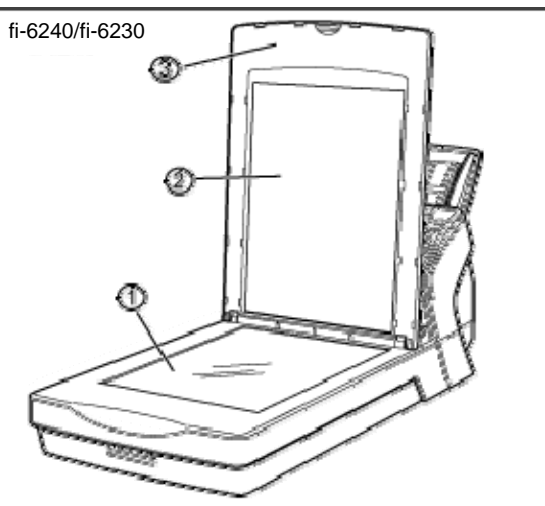

No.	Parts name	Function
1	Document bed	Place documents on the glass when scanning through the flatbed.
2	Document holding pad	Holds documents down on the document bed.
3	Document cover	Holds the document loaded at the reading position when closed.

Rev.	DATE	DESIGN	CHECK	APPR.	DESCRIPTION	TITLE	fi-6140/fi-6240/fi-6130/fi-6230/fi-614PR Maintenance Manual		
08	July 27, 09	K.Okada	A.Miyoshi	I.Fujioka	Refer to Revision Record on page 2.	DRAW No.	P1PA03540-B0XX/6	CUST.	
07	Nov.12, 08	K.Okada	T.Anzai	I.Fujioka	Refer to Revision Record on page 2.				
06	Mar.10, 08	K.Okada	T.Anzai	I.Fujioka	Refer to Revision Record on page 2.				
Design	July 27, 2007	K.Okada	CHECK	K.Okada	APPR.	T.Anzai	PFU LIMITED	Page	13 / 257

[Rear]

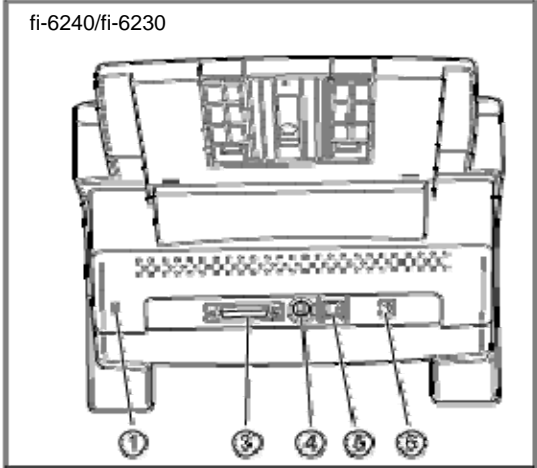
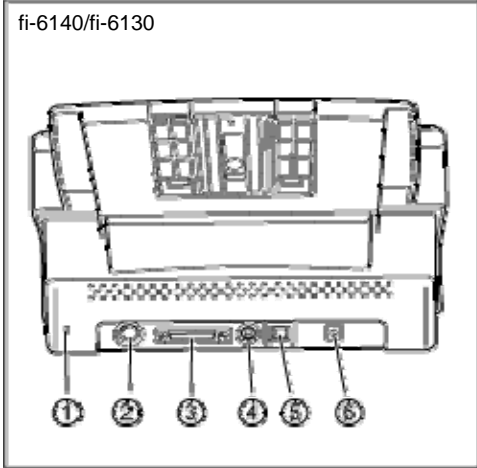

No.	Parts name	Function
1	Security slot	Attaches the antitheft chain
2	EXT connector (for imprinter) [fi-6140/fi-6130 only]	Connects the cable from the Imprinter.
3	SCSI connector	Connects the SCSI interface cable from the host system.
4	SCSI ID switch	Sets the SCSI ID. (default setting: SCSI ID=5)
5	USB connector	Connects the USB cable from the host system.
6	DC inlet	Connects the AC Adapter.

						TITLE	fi-6140/fi-6240/fi-6130/fi-6230/fi-614PR Maintenance Manual	
08	July 27, 09	K.Okada	A.Miyoshi	I.Fujioka	Refer to Revision Record on page 2.	DRAW No.	P1PA03540-B0XX/6	CUST.
07	Nov.12, 08	K.Okada	T.Anzai	I.Fujioka	Refer to Revision Record on page 2.			
06	Mar.10, 08	K.Okada	T.Anzai	I.Fujioka	Refer to Revision Record on page 2.			
Rev.	DATE	DESIGN	CHECK	APPR.	DESCRIPTION	PFU LIMITED		Page
Design	July 27, 2007	K.Okada	CHECK	K.Okada		APPR.	T.Anzai	14 / 257

[Operator Panel]

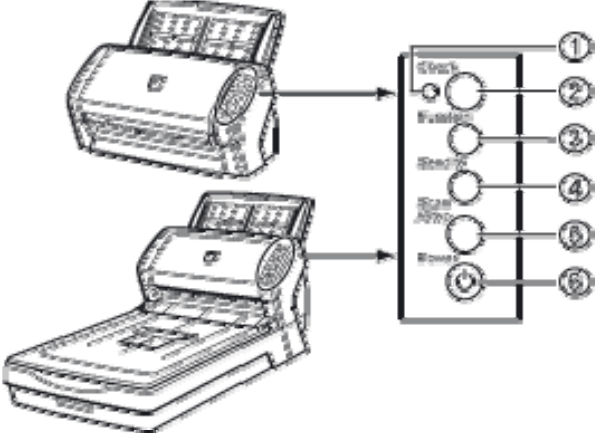

No.	Name	Function
2	Check LED	Lights when an error occurs.
1	Function Number Display	Indicates the function number and error status.
3	[Function] button	Changes the Function activated by the [Send to] button.
4	[Send to] button	Launches the linked application software. Resets an error.
5	[Scan / Stop] button	Launches the linked application software. Resets and error. Cancels ongoing scanning.
6	Power button / LED	Turns the scanner ON and OFF. Lights when the scanner is turned ON.

						TITLE	fi-6140/fi-6240/fi-6130/fi-6230/fi-614PR Maintenance Manual		
08	July 27, 09	K.Okada	A.Miyoshi	I.Fujioka	Refer to Revision Record on page 2.	DRAW No.	P1PA03540-B0XX/6	CUST.	
07	Nov.12, 08	K.Okada	T.Anzai	I.Fujioka	Refer to Revision Record on page 2.				
06	Mar.10, 08	K.Okada	T.Anzai	I.Fujioka	Refer to Revision Record on page 2.				
Rev.	DATE	DESIGN	CHECK	APPR.	DESCRIPTION	PFU LIMITED		Page	15 / 257
Design	July 27, 2007	K.Okada	CHECK	K.Okada		APPR.	T.Anzai		

1-1-5 Outer Dimensions

fi-6140/fi-6130

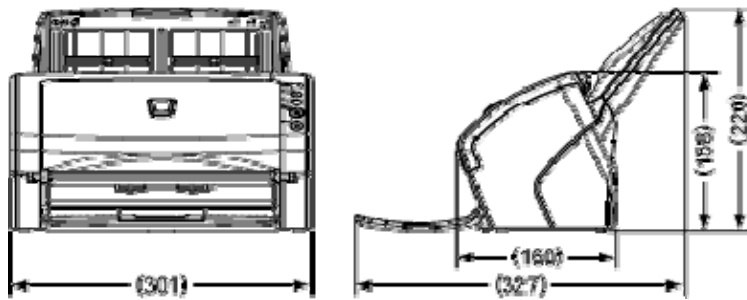

fi-6240/fi-6230

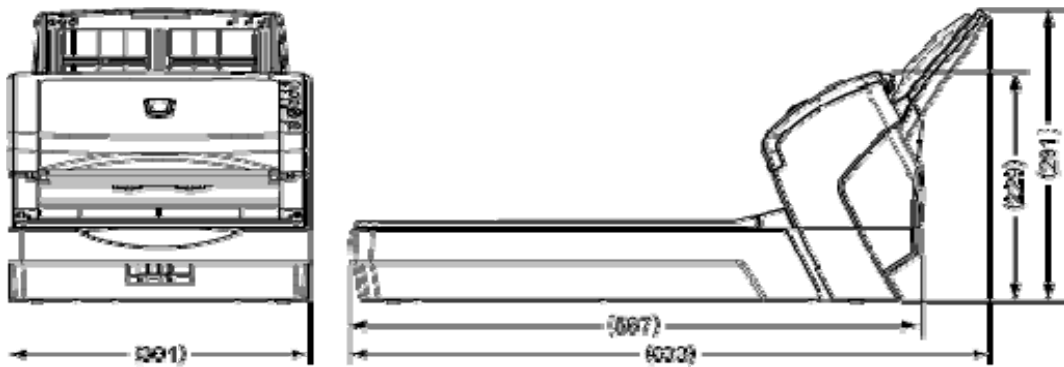

(Unit: mm)

						TITLE	fi-6140/fi-6240/fi-6130/fi-6230/fi-614PR Maintenance Manual		
08	July 27, 09	K.Okada	A.Miyoshi	I.Fujioka	Refer to Revision Record on page 2.	DRAW	P1PA03540-B0XX/6	CUST.	
07	Nov.12, 08	K.Okada	T.Anzai	I.Fujioka	Refer to Revision Record on page 2.	No.			
06	Mar.10, 08	K.Okada	T.Anzai	I.Fujioka	Refer to Revision Record on page 2.				
Rev.	DATE	DESIGN	CHECK	APPR.	DESCRIPTION	PFU LIMITED		Page	16 / 257
Design	July 27, 2007	K.Okada	CHECK	K.Okada		APPR.	T.Anzai		

1-1-6 Document Specifications

- Document Type

The following paper types are recommended for document use:

- Woodfree paper
- Wood containing paper

When using documents of paper type other than the above, check whether or not the document can be scanned by test-scanning a few sheets before executing the actual document.

Any other paper types of documents can be scanned through the Flatbed.

- Document Thickness

Paper thickness is expressed by “paper weight”. The following shows the paper weights that can be used on this scanner:

0.05~0.26mm, 41~210 g/m²

Only paper weight of 127 to 210 g/m² is acceptable for A8-size documents.

- Precautions

The following documents may not be scanned successfully.

- Documents of non-uniform thickness (e.g. envelopes and photo-attached documents)
- Wrinkled or curled documents (See right figure)
- Folded or torn documents
- Tracing paper
- Coated paper
- Carbon paper
- Photosensitive paper
- Perforated documents
- Documents that are not square or rectangular
- Very thin documents
- Photographs

Do not use the following documents:

- Paper-clipped or stapled documents
- Documents on which the ink is still wet
- Documents smaller than A8 (Portrait) in size
- Documents wider than A4 or Letter size (216mm)
- Documents other than paper such as fabric, metal foil, or transparencies
- Important documents such as certificate and cash vouchers that must not get scratched or become smeared

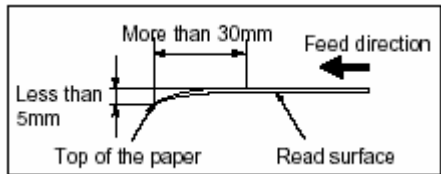
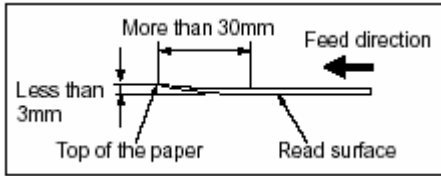

Note: - When scanning semi-transparent documents, slide the [Brightness] bar to light to avoid bleed through.
 - To prevent the rollers from becoming dirty, avoid scanning documents containing large areas written or filled in pencil. If scanning of such document is inevitable, clean the rollers more frequently.

Note: - Carbonless paper contains chemical substances that may harm the Brake roller or paper feeding rollers (e.g. Pick roller) when documents are fed. Pay attention to the following:
Cleaning: If document jams occur frequently, clean the Brake roller and the Pick roller, by referring Section 7-2-1.
Replacing parts: The service life of the Brake roller and the Pick roller may be shortened compared to that of the rollers used for scanning wood containing paper documents.
 - If paper containing wood is scanned, the service life of the Brake roller and the Pick roller may become shorter than that of the rollers used for scanning only woodfree paper.
 - The Brake roller or Pick rollers of the scanner could be damaged if photographs or sheets of paper attached to the scanned document have contact with the Brake or Pick rollers during scanning.
 - Scanning documents of calendered paper such as photographs may damage the surface of them.

						TITLE	fi-6140/fi-6240/fi-6130/fi-6230/fi-614PR Maintenance Manual		
08	July 27, 09	K.Okada	A.Miyoshi	I.Fujioka	Refer to Revision Record on page 2.	DRAW	P1PA03540-B0XX/6	CUST.	
07	Nov.12, 08	K.Okada	T.Anzai	I.Fujioka	Refer to Revision Record on page 2.	No.			
06	Mar.10, 08	K.Okada	T.Anzai	I.Fujioka	Refer to Revision Record on page 2.				
Rev.	DATE	DESIGN	CHECK	APPR.	DESCRIPTION	PFU LIMITED		Page	17/257
Design	July 27, 2007	K.Okada	CHECK	K.Okada		APPR.	T.Anzai		

1-1-7 Multi feed Detection Condition

One of the following method of multi feed detection is selected by the driver.

- Check overlapping
- Check length
- Check overlapping and length

The following condition is required for each selection:

1) Check overlapping

- Paper weight: 0.05 – 0.26 mm, 41~210 g/m²
- Punched holes are not allowed within 35 mm (2.12 in) of the vertical centerline of the document.
- Other paper shall not be glued within 35 mm (2.12 in) of the vertical centerline of the document.

2) Check length

- Document length deviation: 1 % or less
- Punched holes are not allowed within 35 mm (2.12 in) of the vertical centerline of the document.

3) Check overlapping and length

- Paper weight: 0.05 – 0.26 mm, 41~210 g/m²
- Document length deviation: 1 % or less
- Punched holes are not allowed within 35 mm (2.12 in) of the vertical centerline of the document.
- Other paper shall not be glued within 35 mm (2.12 in) of the vertical centerline of the document.

When the overlapping check is specified, the papers which contact closely each other, such as glued paper or electro-statically charged paper, can result in the miss-detection of multi feed.

Multifeed detection monitoring area

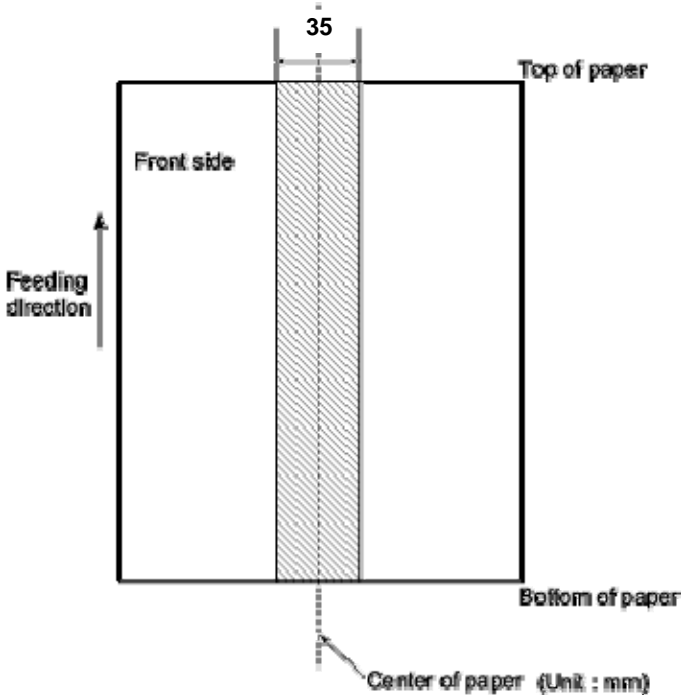

						TITLE	fi-6140/fi-6240/fi-6130/fi-6230/fi-614PR Maintenance Manual		
08	July 27, 09	K.Okada	A.Miyoshi	I.Fujioka	Refer to Revision Record on page 2.	DRAW No.	P1PA03540-B0XX/6	CUST.	
07	Nov.12, 08	K.Okada	T.Anzai	I.Fujioka	Refer to Revision Record on page 2.				
06	Mar.10, 08	K.Okada	T.Anzai	I.Fujioka	Refer to Revision Record on page 2.				
Rev.	DATE	DESIGN	CHECK	APPR.	DESCRIPTION	PFU LIMITED		Page	18 / 257
Design	July 27, 2007	K.Okada	CHECK	K.Okada		APPR.	T.Anzai		

1-2 Scanner Configuration

1-2-1 ADF Unit

(1) Paper separation

When scanning with the ADF, documents loaded on the ADF paper chute (Chute Unit) are separated respectively by the Pick rollers and Brake rollers and fed into the ADF. Separated documents are transported by the feed rollers at the speed that corresponds to specified reading resolution until they are ejected to the stacker.

Paper feeding unit includes Hopper empty sensor (Sensor EMP), PICK sensor, TOP sensor, Multi feed sensor (US Sensor), Paper protection roller (fi-6140/fi-6240 only) and Cover Open Sensor.

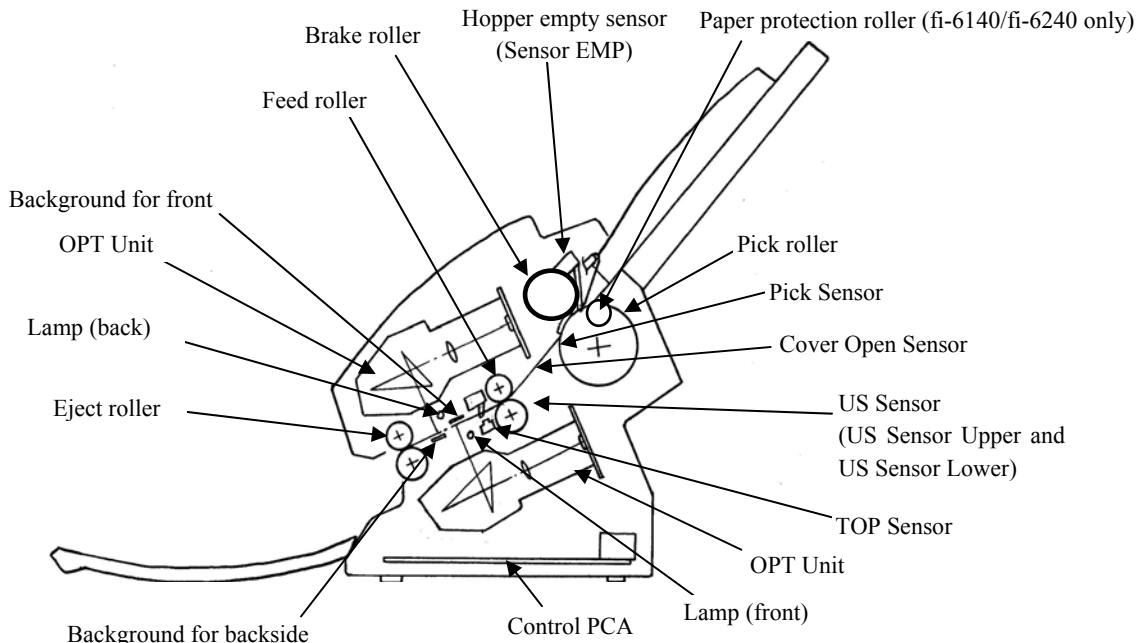

(2) Consumables

The Pick roller and Brake roller are consumables and need to be replaced by a user. (Refer to Section 7-3 for detail.)

The scanner supports two consumable counters, Pick roller counter and Brake roller counter, which indicate the number of sheets that have been scanned so far. Users can check the counters from the driver screen or scanner built-in Maintenance mode, and reset the counter after replacing the consumables. (See Section 6-1-6 for details.)

(3) Drive unit

The Pick rollers are driven by the PICK Motor. The Brake rollers, Feed rollers, and Eject rollers are turned by the ADF Motor. The PICK Motor and ADF Motor are controlled separately. This can widen the gap between documents and extend the amount of overscan while overscanning.

The motor drive circuit and motor fuse are located in the Control PCA. If abnormal electric current runs through the motor drive circuit, the current is cut off by the motor fuse in the Control PCA.

						TITLE	fi-6140/fi-6240/fi-6130/fi-6230/fi-614PR Maintenance Manual		
08	July 27, 09	K.Okada	A.Miyoshi	I.Fujioka	Refer to Revision Record on page 2.	DRAW	No.	P1PA03540-B0XX/6	CUST.
07	Nov.12, 08	K.Okada	T.Anzai	I.Fujioka	Refer to Revision Record on page 2.				
06	Mar.10, 08	K.Okada	T.Anzai	I.Fujioka	Refer to Revision Record on page 2.				
Rev.	DATE	DESIGN	CHECK	APPR.	DESCRIPTION	PFU LIMITED		Page	19 / 257
Design	July 27, 2007	K.Okada	CHECK	K.Okada		APPR.	T.Anzai		

1-2-2 Reading Station

(1) ADF optical system

Documents are set in the ADF paper chute (Chuter Unit) facing front side down. The front side of a document is scanned by the Optical Unit in the Base Unit, and the backside of a document is scanned by the Optical Unit in the Upper Unit. These two Optical Units have the same part number.

An image on a document is projected to a color CCD through lens and mirror system and converted to signals with 10 bit per pixel at 600 dpi resolution.

(2) FB optical system **fi-6240/fi-6230**

When FB scanning is specified, a document set on the document bed (glass) is scanned by the Optical Unit of the Carrier unit, which moves in the direction of sub scanning.

The Carrier unit also includes the Lamp and the Inverter to illuminate the document. The Optical Unit, Lamp and Inverter used in FB are the same type as those used in ADF.

(3) FB scanning control **fi-6240/fi-6230**

During initial processing immediately after power-on, the Carrier unit moves to the home position (the opposite side of ADF). When FB scanning is specified, the scanner moves the Carrier unit to scan the white reference in FB and then adjust the gain of CCD amplifier as a result of scanning the white reference. At that time, if the CCD output does not reach the standard level even after increasing the gain to the maximum level, an optical alarm occurs.

After successful gain adjustment, the scanner scans the specified length of the document while shifting the Carrier unit in the sub scanning direction at the speed that corresponds to the specified scanning resolution. If abnormal electric current runs through the FB Motor, the current is cut off by the motor fuse (the same type as that used in ADF) in Control PCA.

(4) Light source

The scanner uses three Lamps (Incandescent fluorescent lamp) which illuminate the scanning areas in order to get sufficient CCD output. The Lamps are turned ON/OFF by the Inverters that are controlled by the Control PCA.

The life of a Lamp is about 10,000 hours, which means the Lamp lasts during the life of device and is not a consumable.

						TITLE	fi-6140/fi-6240/fi-6130/fi-6230/fi-614PR Maintenance Manual		
08	July 27, 09	K.Okada	A.Miyoshi	I.Fujioka	Refer to Revision Record on page 2.	DRAW No.	P1PA03540-B0XX/6	CUST.	
07	Nov.12, 08	K.Okada	T.Anzai	I.Fujioka	Refer to Revision Record on page 2.				
06	Mar.10, 08	K.Okada	T.Anzai	I.Fujioka	Refer to Revision Record on page 2.				
Rev.	DATE	DESIGN	CHECK	APPR.	DESCRIPTION	PFU LIMITED		Page	20 / 257
Design	July 27, 2007	K.Okada	CHECK	K.Okada		APPR.	T.Anzai		

(5) Scan controller

Before scanning a document, the scanner scans white background of the scanning area and adjusts the gain of CCD amplifier. If the CCD output does not reach a certain level after the gain adjustment, Optical alarm is issued.

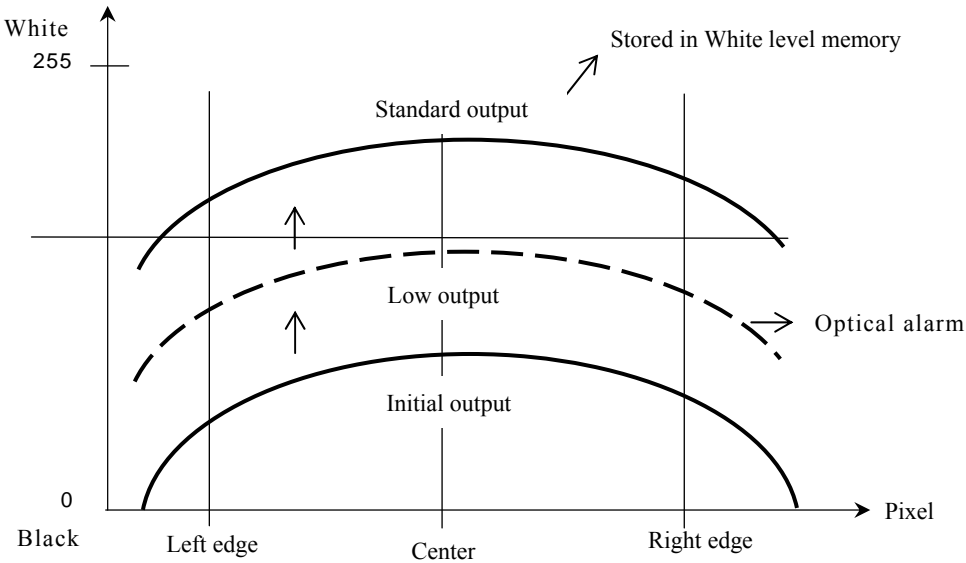

When the gain adjustment completes successfully, the scanner feeds the document to the scanning area at the speed that corresponds to specified scanning resolution. Then the leading edge of the document is detected by the TOP sensor in front of the scanning area. After the document is fed from TOP sensor by some defined length for front and back side scanning (the length which determines sub-scanning offset), the scanner starts scanning the image. The scanner terminates scan operation when the length specified from the host is scanned (Fixed size scanning) or when the TOP sensor detects the trailing edge of a document (Page end detection scanning).

						TITLE	fi-6140/fi-6240/fi-6130/fi-6230/fi-614PR Maintenance Manual		
08	July 27, 09	K.Okada	A.Miyoshi	I.Fujioka	Refer to Revision Record on page 2.	DRAW	P1PA03540-B0XX/6	CUST.	
07	Nov.12, 08	K.Okada	T.Anzai	I.Fujioka	Refer to Revision Record on page 2.	No.			
06	Mar.10, 08	K.Okada	T.Anzai	I.Fujioka	Refer to Revision Record on page 2.				
Rev.	DATE	DESIGN	CHECK	APPR.	DESCRIPTION	PFU LIMITED		Page	21 / 257
Design	July 27, 2007	K.Okada	CHECK	K.Okada		APPR.	T.Anzai		

1-2-3 Controller

(1) Control PCA

Control PCA controls the units shown in the figure below. It includes the following connectors and a switch.

- SCSI connector (fi-6140/fi-6240 only)
- USB connector
- DC voltage input connector
- SCSI ID setting rotary switch

If both SCSI and USB cables are connected,
 - SCSI is selected when selection phase is recognized first.
 - USB is selected when H level VBUS signal is detected first.

The firmware can be updated through a SCSI/USB interface using firmware update tool.

fi-6140/fi-6130

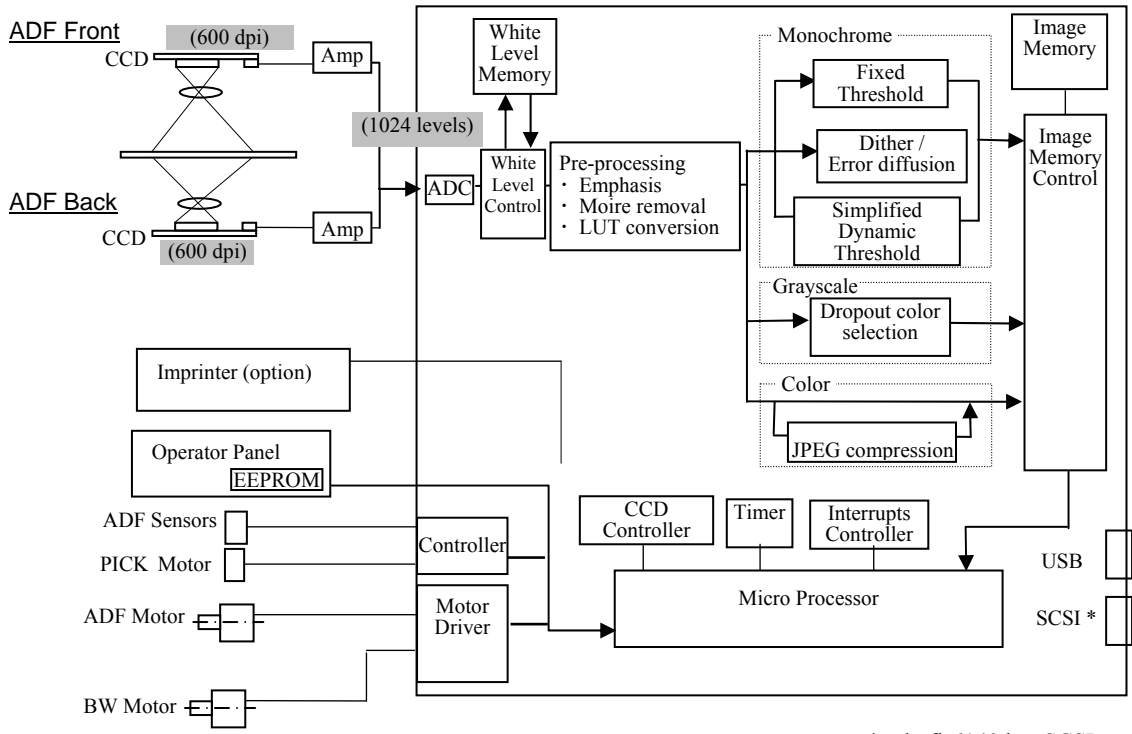

*only fi-6140 has SCSI.

						TITLE	fi-6140/fi-6240/fi-6130/fi-6230/fi-614PR		
08	July 27, 09	K.Okada	A.Miyoshi	I.Fujioka	Refer to Revision Record on page 2.		Maintenance Manual		
07	Nov.12, 08	K.Okada	T.Anzai	I.Fujioka	Refer to Revision Record on page 2.	DRAW No.	P1PA03540-B0XX/6		CUST.
06	Mar.10, 08	K.Okada	T.Anzai	I.Fujioka	Refer to Revision Record on page 2.				
Rev.	DATE	DESIGN	CHECK	APPR.	DESCRIPTION	PFU LIMITED		Page	22 / 257
Design	July 27, 2007	K.Okada	CHECK	K.Okada		APPR.	T.Anzai		

fi-6240/fi-6230

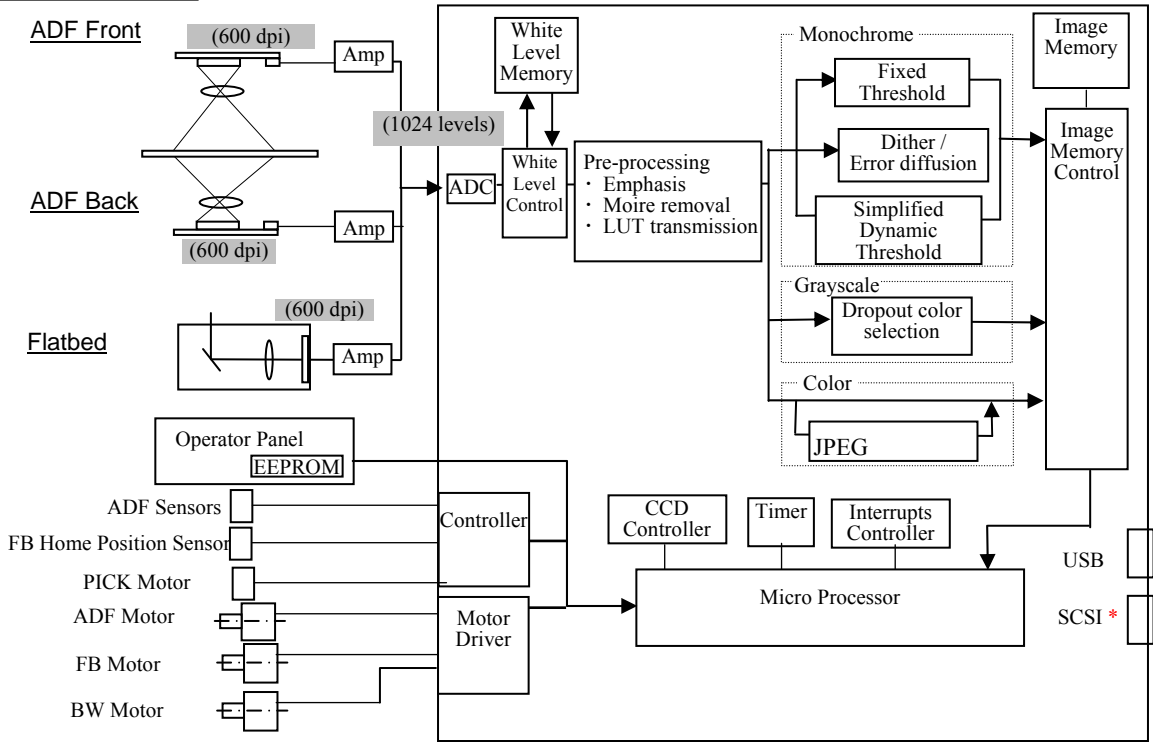

*only fi-6240 has SCSI.

(2) Panel PCA

The Panel PCA in operator panel includes not only the switch and operator panel described in Section 1-1-4, but also EEPROM that records the information below. When replacing the Panel PCA with new one, you need to move all data stored in the EEPROM to the Control PCA, and then return the data from the Control PCA to the new Panel PCA.

- Magnification correction value for main/sub scanning direction
- Offset correction value for main/sub scanning direction
- White level correction value
- Values of Brake roller counter and Pick roller counter
- First date of the scanner operation, ADF scanned number of documents

(3) Joint PCA fi-6240/fi-6230

This is a PCA installed in carrier unit (a unit including Optical Unit, Lamp, Lamp Inverter) of flatbed and used to convert the connector interface among CR Cable, the cable from Optical Unit and Lamp Inverter.

						TITLE	fi-6140/fi-6240/fi-6130/fi-6230/fi-614PR		
08	July 27, 09	K.Okada	A.Miyoshi	I.Fujioka	Refer to Revision Record on page 2.		Maintenance Manual		
07	Nov.12, 08	K.Okada	T.Anzai	I.Fujioka	Refer to Revision Record on page 2.	DRAW	P1PA03540-B0XX/6		CUST.
06	Mar.10, 08	K.Okada	T.Anzai	I.Fujioka	Refer to Revision Record on page 2.	No.			
Rev.	DATE	DESIGN	CHECK	APPR.	DESCRIPTION	PFU LIMITED		Page	23 / 257
Design	July 27, 2007	K.Okada	CHECK	K.Okada		APPR.	T.Anzai		

1-2-4 Electric Component Block Diagram

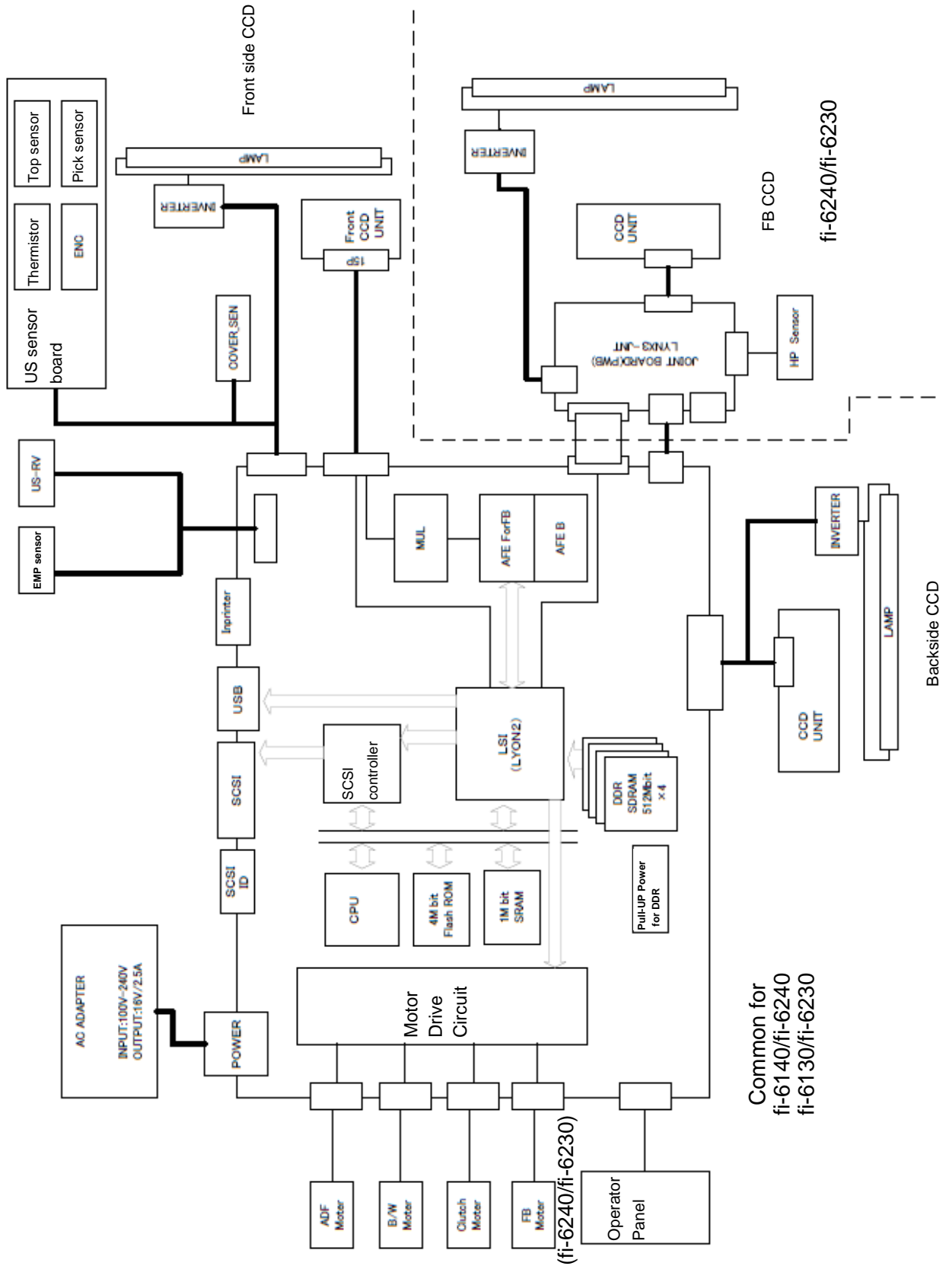

						TITLE	fi-6140/fi-6240/fi-6130/fi-6230/fi-614PR Maintenance Manual		
08	July 27, 09	K.Okada	A.Miyoshi	I.Fujioka	Refer to Revision Record on page 2.	DRAW No.	P1PA03540-B0XX/6		CUST.
07	Nov.12, 08	K.Okada	T.Anzai	I.Fujioka	Refer to Revision Record on page 2.				
06	Mar.10, 08	K.Okada	T.Anzai	I.Fujioka	Refer to Revision Record on page 2.				
Rev.	DATE	DESIGN	CHECK	APPR.	DESCRIPTION	PFU LIMITED		Page	24 / 257
Design	July 27, 2007	K.Okada	CHECK	K.Okada		APPR.	T.Anzai		

Chapter 2 Description of Scanner Operation

2-1 Unpacking the scanner

Follow the procedure below to unpack the scanner package. Make sure that all the accessories are included in the package.

1. Remove the tape to open the package box.
2. Take out the CD tray and other accessories.
3. Take out the scanner and cushions. And remove the cushioning materials.
4. Open the polyethylene bag to take out the scanner.
5. Take out all the accessories and remove the tape protecting the scanner.

The following table lists the packaging configuration.

fi-6140/fi-6130

No.	Items	Quantity
1	Package box	1
2	CD tray (including accessories)	1
3	Cushion TR	1
4	Cushion TL	1
5	Cushion BR	1
6	Cushion BL	1
7	Scanner in Polyethylene bag	1
8	ADF paper chute (Chute Unit) and other accessories	1

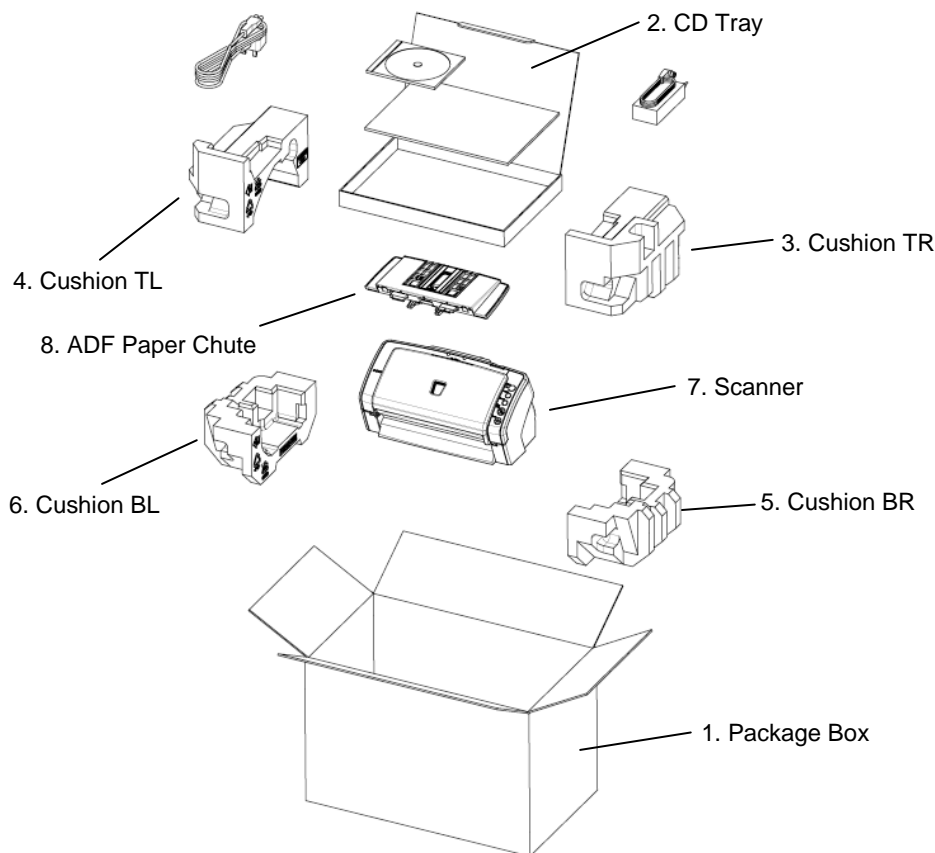

Rev.	DATE	DESIGN	CHECK	APPR.	DESCRIPTION	TITLE	fi-6140/fi-6240/fi-6130/fi-6230/fi-614PR Maintenance Manual	
08	July 27, 09	K.Okada	A.Miyoshi	I.Fujioka	Refer to Revision Record on page 2.	DRAW No.	P1PA03540-B0XX/6	CUST.
07	Nov.12, 08	K.Okada	T.Anzai	I.Fujioka	Refer to Revision Record on page 2.			
06	Mar.10, 08	K.Okada	T.Anzai	I.Fujioka	Refer to Revision Record on page 2.			
Design	July 27, 2007	K.Okada	CHECK	K.Okada	APPR.	T.Anzai	PFU LIMITED	Page 25 / 257

fi-6240/fi-6230

No.	Items	Quantity
1	Package box	1
2	CD tray (including accessories)	1
3	Cushion TR	1
4	Cushion TL	1
5	Cushion BR	1
6	Cushion BL	1
7	Scanner in Polyethylene bag	1
8	ADF paper chute (Chute Unit) and other accessories	1

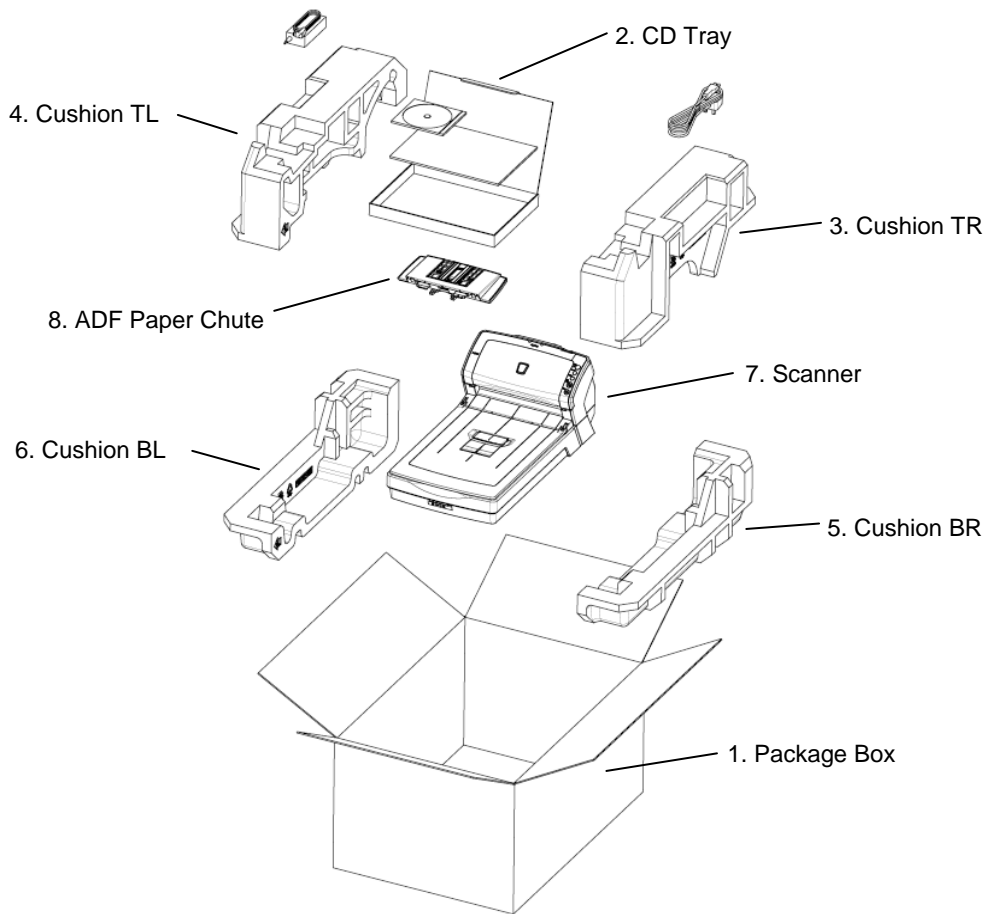

						TITLE	fi-6140/fi-6240/fi-6130/fi-6230/fi-614PR Maintenance Manual		
08	July 27, 09	K.Okada	A.Miyoshi	I.Fujioka	Refer to Revision Record on page 2.	DRAW	P1PA03540-B0XX/6	CUST.	
07	Nov.12, 08	K.Okada	T.Anzai	I.Fujioka	Refer to Revision Record on page 2.	No.			
06	Mar.10, 08	K.Okada	T.Anzai	I.Fujioka	Refer to Revision Record on page 2.				
Rev.	DATE	DESIGN	CHECK	APPR.	DESCRIPTION	PFU LIMITED		Page	26 / 257
Design	July 27, 2007	K.Okada	CHECK	K.Okada		APPR.	T.Anzai		

2-2 Installing the scanner

2-2-1 For safety installation

Before installing the scanner, read the following cautions carefully to avoid scanner trouble.
 Refer to Section 1-1-3 “Environmental Specifications” for information of power source and scanner dimensions.

- Install the scanner away from strong magnetic fields and other sources of noise.
- Do not install the scanner near heating apparatus or in the direct sunlight.
- Install the scanner in a location which is level and subject to minimal vibration.
- Do not install the scanner in locations subject to humidity and dust.
- Do not block the ventilation ports.
- Protect the scanner from static electricity.
- Use proper AC voltage.
- Make sure the rubber pads on the bottom of the scanner grounds evenly.

2-2-2 Installation

(1) **fi-6140/fi-6130** If you wish to install the imprinter (optional), refer to Section 8-3-2 before performing the following procedures.

(2) **fi-6240/fi-6230** Unlock the Transport lock.
 The carrier unit inside the fi-6240/fi-6230 is fixed in place with the transport lock to prevent the scanner from being damaged during transportation. To unlock the transport lock, slide the transport lock switch on the scanner front.

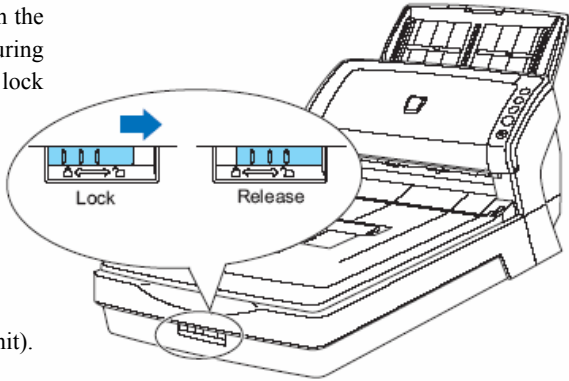

(3) Referring to Section 5-8-1, attach the ADF paper chute (Chuter Unit).

(4) Connect the AC cable to the AC Adapter.
 Note: Use only the supplied AC adapter.

(5) Connect the AC adapter connector to the scanner’s DC inlet. (right figure)

(6) Plug the AC cable into an outlet. If you want to plug it into a two-slot outlet, use the supplied adapter plug.

- Notes:
- Before plugging the adapter plug into an outlet, be sure to establish a ground.
 - The Function Number Display and LED of the operator panel of the scanner may flash for an instant when the AC cable is plugged into an outlet. This is a phenomenon due to the initial diagnosis, but not a failure.

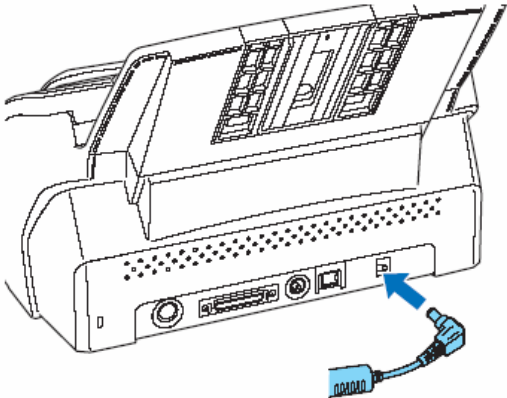

						TITLE	fi-6140/fi-6240/fi-6130/fi-6230/fi-614PR Maintenance Manual		
08	July 27, 09	K.Okada	A.Miyoshi	I.Fujioka	Refer to Revision Record on page 2.	DRAW	P1PA03540-B0XX/6	CUST.	
07	Nov.12, 08	K.Okada	T.Anzai	I.Fujioka	Refer to Revision Record on page 2.	No.			
06	Mar.10, 08	K.Okada	T.Anzai	I.Fujioka	Refer to Revision Record on page 2.				
Rev.	DATE	DESIGN	CHECK	APPR.	DESCRIPTION	PFU LIMITED		Page	27 / 257
Design	July 27, 2007	K.Okada	CHECK	K.Okada		APPR.	T.Anzai		

(7) Connect either with the USB cable or the SCSI cable. (fi-6130/fi-6230 has USB cable only.)

Note 1: Connect only one of the USB or SCSI cable.

Note 2: Be sure to use the USB cable which comes as an accessory with this scanner. Scanning operation with commercially available cables is not guaranteed.

Note 3: When connecting to a USB hub, use the first stage USB hub that is closest to the computer. If you use the second or later hub stages, the scanner may not operate correctly.

Note 4: If you connect the scanner with USB 2.0, it is required that the USB port and Hub are compliant with USB 2.0. The scanning speed may slow down if it is connected with USB 1.1.

Note 5: When using the scanner with a SCSI interface, the following SCSI cable and SCSI card must be purchased.

- SCSI cable:

Use a cable which complies with a 50 Pin Contact Shielded High-Density SCSI Device Connector for Ultra SCSI.

- SCSI card:

Find the recommended SCSI card information in the Fujitsu web site (FAQ).

<http://imagescanner.fujitsu.com/>

Note 6: When connecting the SCSI cable, be sure to first connect the SCSI cable, and, then turn on the scanner and the PC.

Note 7: In a SCSI daisy chain formation, connect the scanner so that it is the terminated device.

(8) The SCSI ID initially set at the factory is [5]. If the SCSI ID of another SCSI device is set to the same ID, either change the scanner's SCSI ID or SCSI ID of the other SCSI device. Turn off the scanner, and then set the SCSI ID using the SCSI ID switch on the back of the scanner.

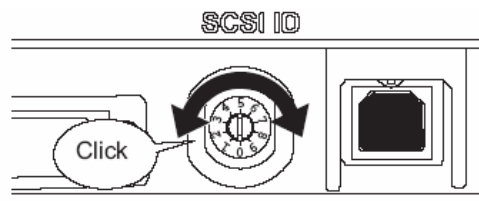

ID No.	Description
0 to 7	Can be set as the ID
8, 9	Works with the factory default value (SCSI ID=5).

(9) Press the Power button to turn ON the scanner.

(10) Turn ON the computer.

(11) Install either of the scanner drivers below and ScandAll PRO and Error Recovery Guide.

Scanner drivers:

- FUJITSU TWAIN 32
- FUJITSU ISIS

Scanning Application:

- ScandAll PRO (Supports both FUJITSU TWAIN 32 and ISIS)

Information at scanner error:

- Error Recovery Guide

						TITLE	fi-6140/fi-6240/fi-6130/fi-6230/fi-614PR Maintenance Manual		
08	July 27, 09	K.Okada	A.Miyoshi	I.Fujioka	Refer to Revision Record on page 2.	DRAW No.	P1PA03540-B0XX/6	CUST.	
07	Nov.12, 08	K.Okada	T.Anzai	I.Fujioka	Refer to Revision Record on page 2.				
06	Mar.10, 08	K.Okada	T.Anzai	I.Fujioka	Refer to Revision Record on page 2.				
Rev.	DATE	DESIGN	CHECK	APPR.	DESCRIPTION	PFU LIMITED		Page	28 / 257
Design	July 27, 2007	K.Okada	CHECK	K.Okada		APPR.	T.Anzai		

Chapter 3 Maintenance Parts

POS	Description	Part Number	Quantity							Ref. for appearance	Ref. for replacement	Remarks
			fi-6140	fi-6240	fi-6130	fi-6230						
ADF Section												
1	BASE UNIT	PA03540-D941	1		1					3-1	5-9-1	
	BASE UNIT L	PA03540-D951					1		1			
2	BASE ASSY	PA03540-E941		1		1				3-2	5-9-2	
	BASE ASSY L	PA03540-E951					1		1			
3	INVERTER	PA03540-K910		1		1		1		3-3	5-9-3	
4	LAMP	PA03540-K911		1		1		1		3-4	5-9-4	
5	US SENSOR FX	PA03540-K913		1		1		1		3-5	5-9-5	Multifeed detection
6	OPT UNIT	PA03540-E903		1		1		1		3-6	5-9-6	
7	BW MOTOR	PA03540-F901		1		1		1		3-7	5-9-7	
8	GUIDE P ASSY(Sheet guide)	PA03540-E908		1		1				3-8	5-9-8	
	GUIDE P ASSY L(Sheet guide)	PA03540-E909					1		1			
9	PICK MOTOR ASSY	PA03540-F904		1		1		1		3-9	5-9-9	
10	PICK MOTOR	PA03540-F903		1		1		1		3-10	5-9-10	
11	PICK SHAFT ASSY	PA03540-F907		1		1		1		3-11	5-9-11	
12	SWITCH	PA03484-K804		1		1		1		3-12	5-9-12	ADF open detection.
13	UPPER UNIT	PA03540-D961	1							3-13	5-10-1	*1
	UPPER UNIT C	PA03540-D967										*2
	UPPER UNIT	PA03540-D971			1				*1			
	UPPER UNIT C	PA03540-D977							*2			
	UPPER UNIT L	PA03540-D981				1			*1			
	UPPER UNIT LC	PA03540-D987							*2			
	UPPER UNIT L	PA03540-D991						1	*1			
	UPPER UNIT LC	PA03540-D997							*2			
14	UPPER ASSY	PA03540-E931		1		1		1		3-14	5-10-2	
15	ADF MOTOR	PA03540-K915		1		1		1		3-15	5-10-3	
16	OPT UNIT	PA03540-E903		1		1		1		3-6	5-10-4	
17	INVERTER	PA03540-K910		1		1		1		3-3	5-10-5	
18	LAMP	PA03540-K911		1		1		1		3-4	5-10-6	
19	US SENSOR RV	PA03484-K905		1		1		1		3-19	5-10-7	Multifeed detection *3
20	SENSOR EMP	PA03540-K906		1		1		1		3-20	5-10-8	Paper empty detection
21	PANEL PCA	PA03540-K907		1		1		1		3-21	5-10-9	
22	BR SHAFT ASSY	PA03540-F905		1		1		1		3-22	5-10-10	

*1: For Europe, North America

*2: For China

*3: Shared with fi-5120C/fi-5220C.

						TITLE	fi-6140/fi-6240/fi-6130/fi-6230/fi-614PR Maintenance Manual				
08	July 27, 09	K.Okada	A.Miyoshi	I.Fujioka	Refer to Revision Record on page 2.	DRAW No.	P1PA03540-B0XX/6				CUST.
07	Nov.12, 08	K.Okada	T.Anzai	I.Fujioka	Refer to Revision Record on page 2.						
06	Mar.10, 08	K.Okada	T.Anzai	I.Fujioka	Refer to Revision Record on page 2.						
Rev.	DATE	DESIGN	CHECK	APPR.	DESCRIPTION	PFU LIMITED		Page	29 / 257		
Design	July 27, 2007	K.Okada	CHECK	K.Okada		APPR.	T.Anzai				

Maintenance Parts (Cont'd)

POS	Description	Part Number	Quantity								Ref. for appearance	Ref. for replacement	Remarks
			fi-6140	fi-6240	fi-6130	fi-6230							
23	CONTROL PCA	PA03540-K901	1								3-23	5-11	
		PA03540-K917		1									
24	CONTROL PCA L	PA03540-K918				1					3-23	5-11	
		PA03540-K919						1					
25	STACKER UNIT	PA03540-E904	1			1					3-25	5-8-2	
26	CHUTER UNIT (ADF paper chute)	PA03540-E905	1		1		1		1		3-26	5-8-1	
27	AC ADAPTER	PA03334-K920	1		1		1		1		3-27		*4
28	AC CORDSET E	PA63083-1831	1		1		1		1		3-28		For Europe
	AC CORDSET UK	PA63098-1831											For UK
	AC CORDSET U	PA63082-1831											For North America
	AC CORDSET C	PA63084-1831											For China
29	USB CABLE	PA61001-0142	1		1		1		1		3-29		
Flatbed													
30	FB TOP COV ASSY	PA03540-E961			1				1		3-30	5-12-1	
31	FB MOTOR UNIT	PA03540-E919			1				1		3-31	5-12-2	
32	FB MOTOR	PA03540-E909			1				1		3-32	5-12-3	
		PA03540-F90904											
33	OPT BOX UNIT	PA03540-E910			1				1		3-33	5-12-4	
34	OPT UNIT	PA03540-E903			1				1		3-6	5-12-5	
35	INVERTER	PA03540-K910			1				1		3-3	5-12-6	
36	LAMP	PA03540-K911			1				1		3-4	5-12-7	
37	CR CABLE	PA70002-0928			1				1		3-37	5-12-8	*5
38	DOC COV ASSY	PA03540-E921			1				1		3-38	5-12-9	
39	JOINT PCA	PA03540-K916			1				1		3-39	5-12-10	

*4: Shared with fi-5530C2

*5: Shared with fi-5220C

						TITLE	fi-6140/fi-6240/fi-6130/fi-6230/fi-614PR Maintenance Manual					
08	July 27, 09	K.Okada	A.Miyoshi	I.Fujioka	Refer to Revision Record on page 2.	DRAW No.	P1PA03540-B0XX/6				CUST.	
07	Nov.12, 08	K.Okada	T.Anzai	I.Fujioka	Refer to Revision Record on page 2.							
06	Mar.10, 08	K.Okada	T.Anzai	I.Fujioka	Refer to Revision Record on page 2.							
Rev.	DATE	DESIGN	CHECK	APPR.	DESCRIPTION	PFU LIMITED		Page	30 / 257			
Design	July 27, 2007	K.Okada	CHECK	K.Okada		APPR.	T.Anzai					

3-1 BASE UNIT

Description	Parts No.	Remarks	
BASE UNIT	PA03540-D941	fi-6140/fi-6240	
BASE UNIT L	PA03540-D951	fi-6130/fi-6230	

Paper protection sensor

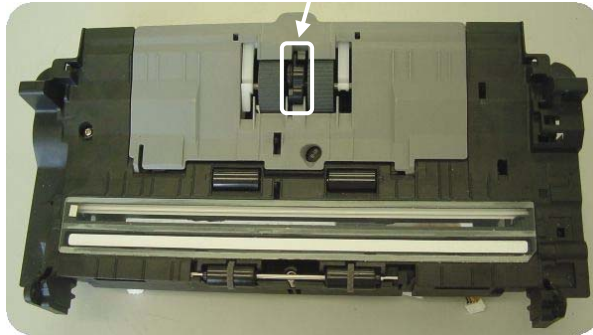

3-2 BASE ASSY

Description	Parts No.	Remarks	
BASE ASSY	PA03540-E941	fi-6140/fi-6240	OPT Unit is not included. (Remove OPT Unit from Base Unit. The remaining assembly is Base ASSY.)
BASE ASSY L	PA03540-E951	fi-6130/fi-6230	

Paper protection sensor

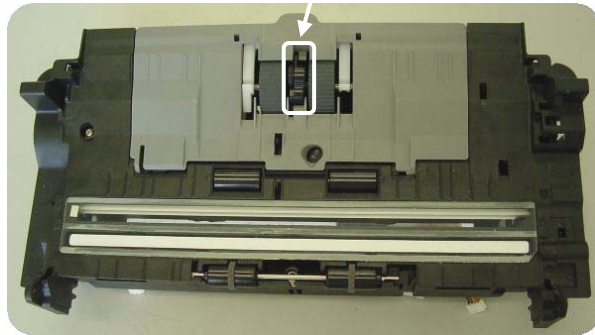

						TITLE	fi-6140/fi-6240/fi-6130/fi-6230/fi-614PR Maintenance Manual		
08	July 27, 09	K.Okada	A.Miyoshi	I.Fujioka	Refer to Revision Record on page 2.	DRAW No.	P1PA03540-B0XX/6	CUST.	
07	Nov.12, 08	K.Okada	T.Anzai	I.Fujioka	Refer to Revision Record on page 2.				
06	Mar.10, 08	K.Okada	T.Anzai	I.Fujioka	Refer to Revision Record on page 2.				
Rev.	DATE	DESIGN	CHECK	APPR.	DESCRIPTION	PFU LIMITED		Page	31 / 257
Design	July 27, 2007	K.Okada	CHECK	K.Okada		APPR.	T.Anzai		

3-3 INVERTER

Description	Parts No.	Remarks
INVERTER	PA03540-K910	

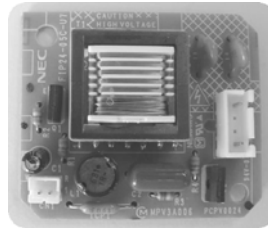

3-4 LAMP

Description	Parts No.	Remarks
LAMP	PA03540-K911	

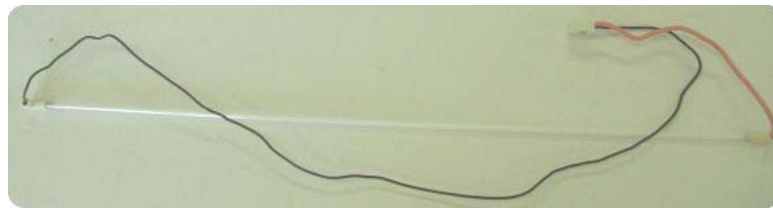

						TITLE	fi-6140/fi-6240/fi-6130/fi-6230/fi-614PR Maintenance Manual		
08	July 27, 09	K.Okada	A.Miyoshi	I.Fujioka	Refer to Revision Record on page 2.	DRAW No.	P1PA03540-B0XX/6	CUST.	
07	Nov.12, 08	K.Okada	T.Anzai	I.Fujioka	Refer to Revision Record on page 2.				
06	Mar.10, 08	K.Okada	T.Anzai	I.Fujioka	Refer to Revision Record on page 2.				
Rev.	DATE	DESIGN	CHECK	APPR.	DESCRIPTION	PFU LIMITED		Page	32 / 257
Design	July 27, 2007	K.Okada	CHECK	K.Okada		APPR.	T.Anzai		

3-5 US SENSOR FX (Multifeed detection)

Description	Parts No.	Remarks
US SENSOR FX	PA03540-K913	Transmitter. PICK sensor and Top sensor are included. US shield FX is not included.

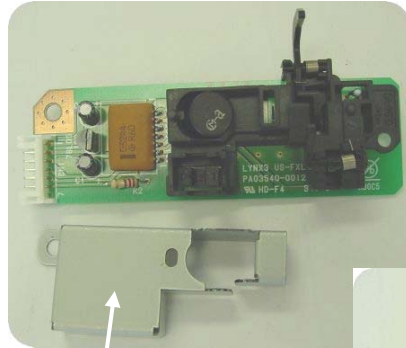

US Shield FX
(not included))

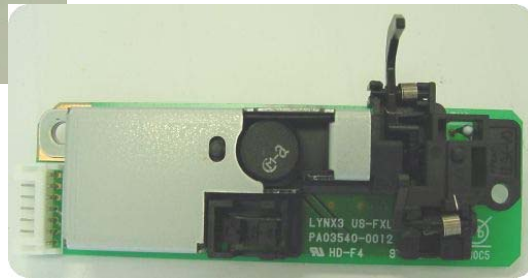

3-6 OPT UNIT

Description	Parts No.	Remarks
OPT UNIT	PA03540-E903	



						TITLE	fi-6140/fi-6240/fi-6130/fi-6230/fi-614PR Maintenance Manual		
08	July 27, 09	K.Okada	A.Miyoshi	I.Fujioka	Refer to Revision Record on page 2.	DRAW No.	P1PA03540-B0XX/6	CUST.	
07	Nov.12, 08	K.Okada	T.Anzai	I.Fujioka	Refer to Revision Record on page 2.				
06	Mar.10, 08	K.Okada	T.Anzai	I.Fujioka	Refer to Revision Record on page 2.				
Rev.	DATE	DESIGN	CHECK	APPR.	DESCRIPTION	PFU LIMITED		Page	33 / 257
Design	July 27, 2007	K.Okada	CHECK	K.Okada	APPR.				

3-7 BW MOTOR

Description	Parts No.	Remarks
BW MOTOR	PA03540-F901	

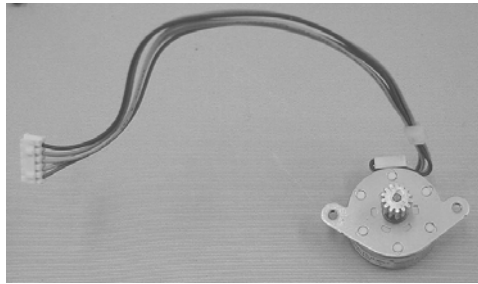

3-8 GUIDE P ASSY (Sheet Guide)

Description	Parts No.	Remarks
GUIDE P ASSY	PA03540-E908	fi-6140/fi-6240
GUIDE P ASSY L	PA03540-E909	fi-6130/fi-6230

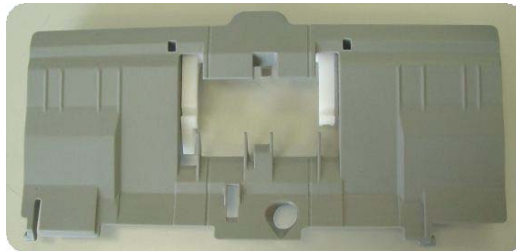

						TITLE	fi-6140/fi-6240/fi-6130/fi-6230/fi-614PR Maintenance Manual		
08	July 27, 09	K.Okada	A.Miyoshi	I.Fujioka	Refer to Revision Record on page 2.	DRAW No.	P1PA03540-B0XX/6	CUST.	
07	Nov.12, 08	K.Okada	T.Anzai	I.Fujioka	Refer to Revision Record on page 2.				
06	Mar.10, 08	K.Okada	T.Anzai	I.Fujioka	Refer to Revision Record on page 2.				
Rev.	DATE	DESIGN	CHECK	APPR.	DESCRIPTION	PFU LIMITED		Page	34 / 257
Design	July 27, 2007	K.Okada	CHECK	K.Okada		APPR.	T.Anzai		

3-9 PICK MOTOR ASSY

Description	Parts No.	Remarks
PICK MOTOR ASSY	PA03540-F904	



3-10 PICK MOTOR

Description	Parts No.	Remarks
PICK MOTOR	PA03540-F903	A belt tension adjusting spring is attached.



Adjusting spring

						TITLE	fi-6140/fi-6240/fi-6130/fi-6230/fi-614PR Maintenance Manual		
08	July 27, 09	K.Okada	A.Miyoshi	I.Fujioka	Refer to Revision Record on page 2.	DRAW No.	P1PA03540-B0XX/6	CUST.	
07	Nov.12, 08	K.Okada	T.Anzai	I.Fujioka	Refer to Revision Record on page 2.				
06	Mar.10, 08	K.Okada	T.Anzai	I.Fujioka	Refer to Revision Record on page 2.				
Rev.	DATE	DESIGN	CHECK	APPR.	DESCRIPTION	PFU LIMITED		Page	35 / 257
Design	July 27, 2007	K.Okada	CHECK	K.Okada		APPR.	T.Anzai		

3-11 PICK SHAFT ASSY

Description	Parts No.	Remarks
PICK SHAFT ASSY	PA03540-F907	

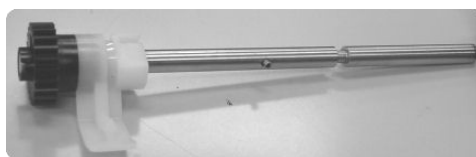

3-12 SWITCH (ADF open detection)

Description	Parts No.	Remarks
SWITCH	PA03540-K804	Shared with fi-5120C/fi-5220C.



						TITLE	fi-6140/fi-6240/fi-6130/fi-6230/fi-614PR Maintenance Manual		
08	July 27, 09	K.Okada	A.Miyoshi	I.Fujioka	Refer to Revision Record on page 2.	DRAW No.	P1PA03540-B0XX/6	CUST.	
07	Nov.12, 08	K.Okada	T.Anzai	I.Fujioka	Refer to Revision Record on page 2.				
06	Mar.10, 08	K.Okada	T.Anzai	I.Fujioka	Refer to Revision Record on page 2.				
Rev.	DATE	DESIGN	CHECK	APPR.	DESCRIPTION	PFU LIMITED		Page	36 / 257
Design	July 27, 2007	K.Okada	CHECK	K.Okada		APPR.	T.Anzai		

3-13 UPPER UNIT

Description	Parts No.	Remarks
UPPER UNIT	PA03540-D961	fi-6140 for Europe and North America
UPPER UNIT C	PA03540-D967	fi-6140 for China
UPPER UNIT	PA03540-D971	fi-6240 for Europe and North America
UPPER UNIT C	PA03540-D977	fi-6240 for China
UPPER UNIT L	PA03540-D981	fi-6130 for Europe and North America
UPPER UNIT LC	PA03540-D987	fi-6130 for China
UPPER UNIT L	PA03540-D991	fi-6230 for Europe and North America
UPPER UNIT LC	PA03540-D997	fi-6230 for China

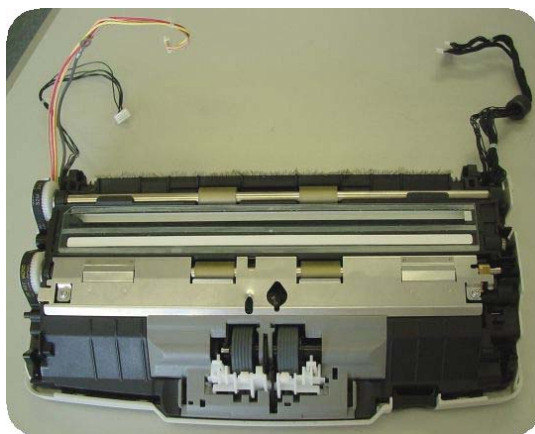

3-14 UPPER ASSY

Description	Parts No.	Remarks
UPPER ASSY	PA03450-E931	Panel PCA and OPT Unit are not included. A dummy TOP cover is included. (Remove OPT Unit from Upper Unit. The remaining assembly is Upper ASSY.)

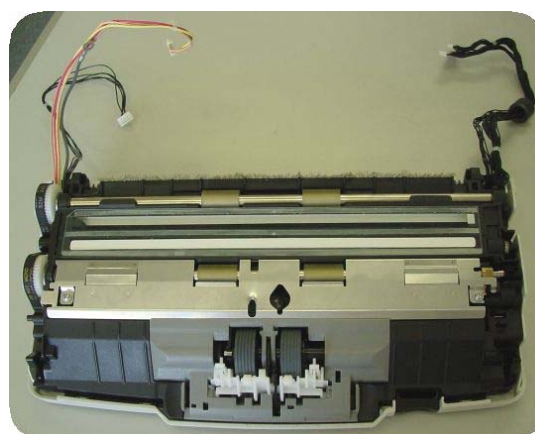

						TITLE	fi-6140/fi-6240/fi-6130/fi-6230/fi-614PR Maintenance Manual		
08	July 27, 09	K.Okada	A.Miyoshi	I.Fujioka	Refer to Revision Record on page 2.	DRAW No.	P1PA03540-B0XX/6	CUST.	
07	Nov.12, 08	K.Okada	T.Anzai	I.Fujioka	Refer to Revision Record on page 2.				
06	Mar.10, 08	K.Okada	T.Anzai	I.Fujioka	Refer to Revision Record on page 2.				
Rev.	DATE	DESIGN	CHECK	APPR.	DESCRIPTION	PFU LIMITED		Page	37 / 257
Design	July 27, 2007	K.Okada	CHECK	K.Okada		APPR.	T.Anzai		

3-15 ADF MOTOR

Description	Parts No.	Remarks
ADF MOTOR	PA03540-K915	A belt tension adjusting spring is attached.



Adjusting spring

3-16 (Reserved)

3-17 (Reserved)

3-18 (Reserved)

3-19 US SENSOR RV (Multifeed detection)

Description	Parts No.	Remarks
US SENSOR RV	PA03484-K905	Receiver. Shared with fi-5120C/fi-5220C

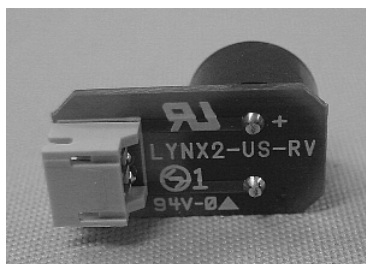

						TITLE	fi-6140/fi-6240/fi-6130/fi-6230/fi-614PR Maintenance Manual		
08	July 27, 09	K.Okada	A.Miyoshi	I.Fujioka	Refer to Revision Record on page 2.	DRAW No.	P1PA03540-B0XX/6	CUST.	
07	Nov.12, 08	K.Okada	T.Anzai	I.Fujioka	Refer to Revision Record on page 2.				
06	Mar.10, 08	K.Okada	T.Anzai	I.Fujioka	Refer to Revision Record on page 2.				
Rev.	DATE	DESIGN	CHECK	APPR.	DESCRIPTION	PFU LIMITED		Page	38 / 257
Design	July 27, 2007	K.Okada	CHECK	K.Okada		APPR.	T.Anzai		

3-20 SENSOR EMP (Paper empty detection)

Description	Parts No.	Remarks
SENSOR EMP	PA03540-K906	

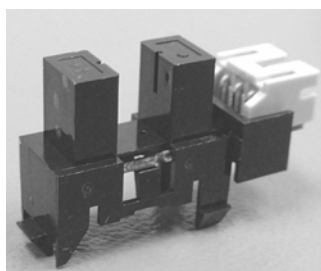

3-21 PANEL PCA

Description	Parts No.	Remarks
PANEL PCA	PA03540-K907	EEPROM data need to be saved. (Refer to Section 6-2.)



3-22 BR SHAFT ASSY

Description	Parts No.	Remarks
BR SHAFT ASSY	PA03540-F905	



						TITLE	fi-6140/fi-6240/fi-6130/fi-6230/fi-614PR Maintenance Manual		
08	July 27, 09	K.Okada	A.Miyoshi	I.Fujioka	Refer to Revision Record on page 2.	DRAW No.	P1PA03540-B0XX/6	CUST.	
07	Nov.12, 08	K.Okada	T.Anzai	I.Fujioka	Refer to Revision Record on page 2.				
06	Mar.10, 08	K.Okada	T.Anzai	I.Fujioka	Refer to Revision Record on page 2.				
Rev.	DATE	DESIGN	CHECK	APPR.	DESCRIPTION	PFU LIMITED		Page	39 / 257
Design	July 27, 2007	K.Okada	CHECK	K.Okada		APPR.	T.Anzai		

3-23 CONTROL PCA

Description	Parts No.		Remarks
CONTROL PCA	PA03540-K901	fi-6140	The bracket is not included.
	PA03540-K917	fi-6240	
CONTROL PCA L	PA03540-K918	fi-6130	The bracket is not included.
	PA03540-K919	fi-6230	

fi-6240/fi-6230

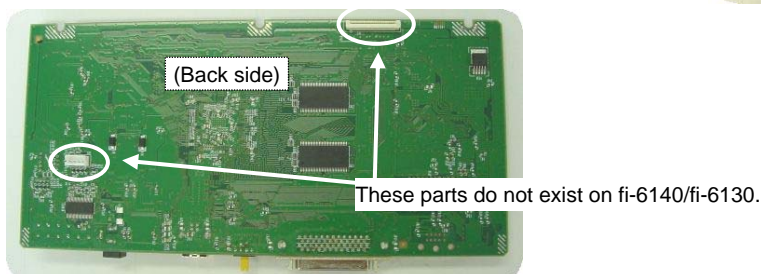
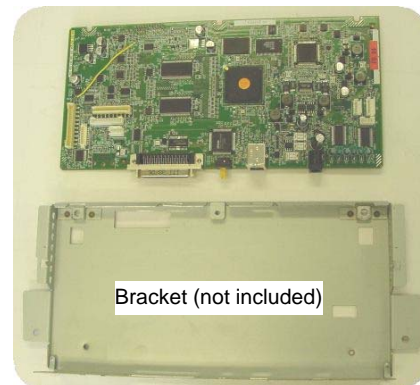

fi-6140/fi-6130



These parts do not exist on fi-6240/fi-6230.

Rev.	DATE	DESIGN	CHECK	APPR.	DESCRIPTION	TITLE			
08	July 27, 09	K.Okada	A.Miyoshi	I.Fujioka	Refer to Revision Record on page 2.	fi-6140/fi-6240/fi-6130/fi-6230/fi-614PR Maintenance Manual			
07	Nov.12, 08	K.Okada	T.Anzai	I.Fujioka	Refer to Revision Record on page 2.		DRAW No.	P1PA03540-B0XX/6	CUST.
06	Mar.10, 08	K.Okada	T.Anzai	I.Fujioka	Refer to Revision Record on page 2.				
Design	July 27, 2007	K.Okada	CHECK	K.Okada	APPR.	T.Anzai	PFU LIMITED	Page	40 / 257

3-24 (Reserved)

3-25 STACKER UNIT

Description	Parts No.	Remarks
STACKER UNIT	PA03540-E904	fi-6140/fi-6130 only



3-26 CHUTER UNIT (ADF paper chute)

Description	Parts No.	Remarks
CHUTER UNIT	PA03540-E905	



						TITLE	fi-6140/fi-6240/fi-6130/fi-6230/fi-614PR Maintenance Manual		
08	July 27, 09	K.Okada	A.Miyoshi	I.Fujioka	Refer to Revision Record on page 2.	DRAW No.	P1PA03540-B0XX/6	CUST.	
07	Nov.12, 08	K.Okada	T.Anzai	I.Fujioka	Refer to Revision Record on page 2.				
06	Mar.10, 08	K.Okada	T.Anzai	I.Fujioka	Refer to Revision Record on page 2.				
Rev.	DATE	DESIGN	CHECK	APPR.	DESCRIPTION	PFU LIMITED		Page	41 / 257
Design	July 27, 2007	K.Okada	CHECK	K.Okada		APPR.	T.Anzai		

3-27 AC ADAPTER

Description	Parts No.	Remarks
AC ADAPTER	PA03334-K920	Shared with fi-5530C2.



3-28 AC CORDSETS

Description	Parts No.	Remarks
AC CORDSET E	PA63083-1831	For Europe
AC CORDSET UK	PA63098-1831	For UK
AC CORDSET U	PA63082-1831	For North America
AC CORDSET C	PA63084-1831	For China



3-29 USB CABLE

Description	Parts No.	Remarks
USB CABLE	PA61001-0142	

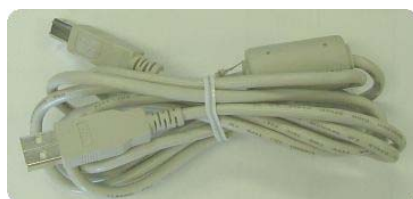

						TITLE	fi-6140/fi-6240/fi-6130/fi-6230/fi-614PR Maintenance Manual		
08	July 27, 09	K.Okada	A.Miyoshi	I.Fujioka	Refer to Revision Record on page 2.	DRAW No.	P1PA03540-B0XX/6	CUST.	
07	Nov.12, 08	K.Okada	T.Anzai	I.Fujioka	Refer to Revision Record on page 2.				
06	Mar.10, 08	K.Okada	T.Anzai	I.Fujioka	Refer to Revision Record on page 2.				
Rev.	DATE	DESIGN	CHECK	APPR.	DESCRIPTION	PFU LIMITED		Page	42 / 257
Design	July 27, 2007	K.Okada	CHECK	K.Okada		APPR.	T.Anzai		

3-30 FB TOP COVER

Description	Parts No.	Remarks
FB TOP COVER	PA03450-E961	FB LID L and FB LID R are not included.

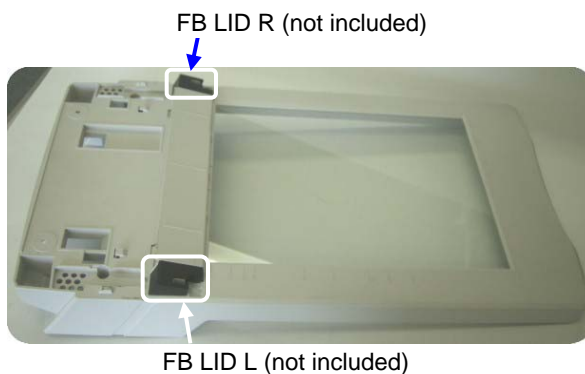

3-31 FB MOTOR UNIT

Description	Parts No.	Remarks
FB MOTOR UNIT	PA03540-E919	A belt tension adjusting spring is attached.

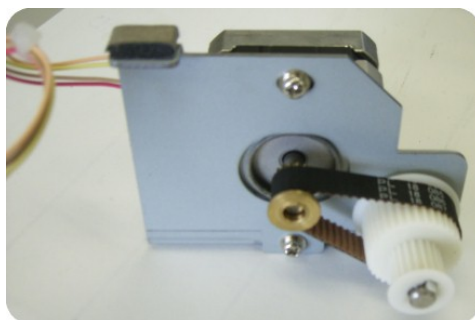

Adjusting spring

						TITLE	fi-6140/fi-6240/fi-6130/fi-6230/fi-614PR Maintenance Manual		
08	July 27, 09	K.Okada	A.Miyoshi	I.Fujioka	Refer to Revision Record on page 2.	DRAW No.	P1PA03540-B0XX/6	CUST.	
07	Nov.12, 08	K.Okada	T.Anzai	I.Fujioka	Refer to Revision Record on page 2.				
06	Mar.10, 08	K.Okada	T.Anzai	I.Fujioka	Refer to Revision Record on page 2.				
Rev.	DATE	DESIGN	CHECK	APPR.	DESCRIPTION	PFU LIMITED		Page	43 / 257
Design	July 27, 2007	K.Okada	CHECK	K.Okada		APPR.	T.Anzai		

3-32 FB MOTOR

Description	Parts No.	Remarks
FB MOTOR	PA03540-E909 PA03540-F909 04	A belt tension adjusting spring is attached. 04

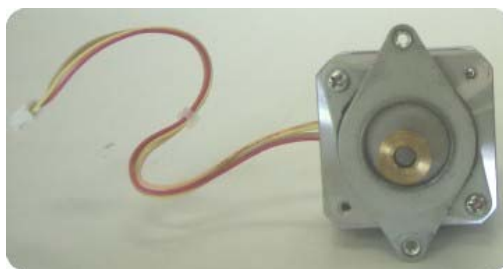

3-33 OPT BOX UNIT

Description	Parts No.	Remarks
OPT BOX UNIT	PA03540-E910	The following parts are NOT included. - OPT UNIT - JOINT PCA - Core - Inverter cable The following parts are included. - INVERTER - LAMP

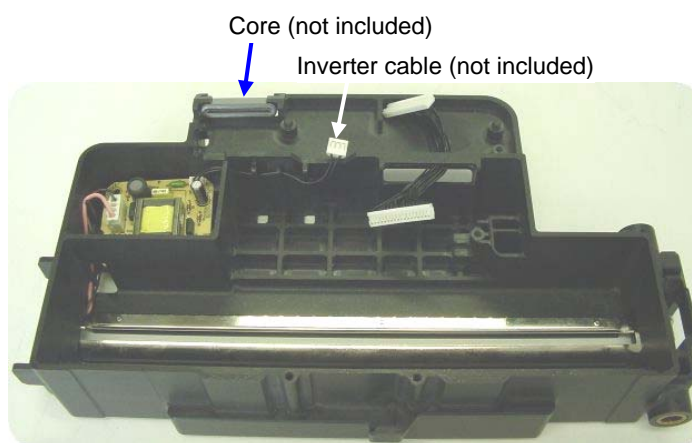

3-34 (Reserved)

3-35 (Reserved)

3-36 (Reserved)

						TITLE	fi-6140/fi-6240/fi-6130/fi-6230/fi-614PR Maintenance Manual		
08	July 27, 09	K.Okada	A.Miyoshi	I.Fujioka	Refer to Revision Record on page 2.	DRAW No.	P1PA03540-B0XX/6	CUST.	
07	Nov.12, 08	K.Okada	T.Anzai	I.Fujioka	Refer to Revision Record on page 2.				
06	Mar.10, 08	K.Okada	T.Anzai	I.Fujioka	Refer to Revision Record on page 2.				
Rev.	DATE	DESIGN	CHECK	APPR.	DESCRIPTION	PFU LIMITED		Page	44 / 257
Design	July 27, 2007	K.Okada	CHECK	K.Okada		APPR.	T.Anzai		

3-37 CR CABLE

Description	Parts No.	Remarks
CR CABLE	PA70002-0928	Shared with fi-5220C

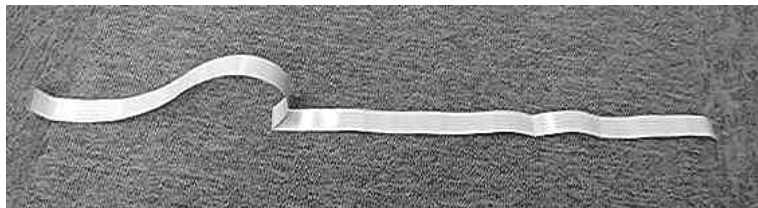
**3-38 DOC COVER ASSY**

Description	Parts No.	Remarks
DOC COVER ASSY	PA03540-E921	Cushion is attached.

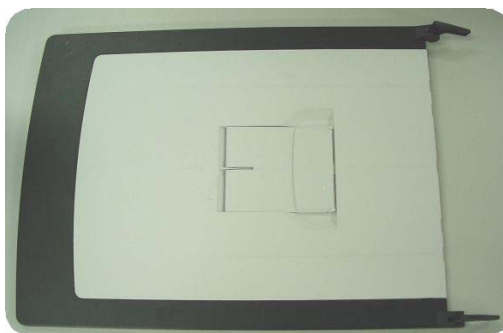

						TITLE	fi-6140/fi-6240/fi-6130/fi-6230/fi-614PR Maintenance Manual		
08	July 27, 09	K.Okada	A.Miyoshi	I.Fujioka	Refer to Revision Record on page 2.	DRAW No.	P1PA03540-B0XX/6	CUST.	
07	Nov.12, 08	K.Okada	T.Anzai	I.Fujioka	Refer to Revision Record on page 2.				
06	Mar.10, 08	K.Okada	T.Anzai	I.Fujioka	Refer to Revision Record on page 2.				
Rev.	DATE	DESIGN	CHECK	APPR.	DESCRIPTION	PFU LIMITED		Page	45 / 257
Design	July 27, 2007	K.Okada	CHECK	K.Okada		APPR.	T.Anzai		

3-39 JOINT PCA

Description	Parts No.	Remarks
JOINT PCA	PA03540-K916	



6-40 (Reserved)

						TITLE	fi-6140/fi-6240/fi-6130/fi-6230/fi-614PR Maintenance Manual		
08	July 27, 09	K.Okada	A.Miyoshi	I.Fujioka	Refer to Revision Record on page 2.	DRAW No.	P1PA03540-B0XX/6	CUST.	
07	Nov.12, 08	K.Okada	T.Anzai	I.Fujioka	Refer to Revision Record on page 2.				
06	Mar.10, 08	K.Okada	T.Anzai	I.Fujioka	Refer to Revision Record on page 2.				
Rev.	DATE	DESIGN	CHECK	APPR.	DESCRIPTION	PFU LIMITED		Page	46 / 257
Design	July 27, 2007	K.Okada	CHECK	K.Okada	APPR.				

Chapter 4 Troubleshooting

4-1 Operation Panel Sequence at Power-on

The following display is shown during initial processing.

Function No. Display	Power LED	Description
	ON	Displays "8" without blinking. Immediately after power-on, scanner turns all the segments ON.

When the initial processing starts, the following display is shown.

Function No. Display	Power LED	Description
	ON	Displays "P" without blinking. It indicates scanner is currently in initial processing.

When the lamp intensity is getting close to the standard value, the following display is shown.

Function No. Display	Power LED	Description
	ON	Displays "0" without blinking. It indicates the lamp intensity is getting close to the standard value.

When the initial processing terminates properly, the following display is shown.

Function No. Display	Power LED	Description
	ON	Displays default Function No. without blinking. It indicates that scanner is in ready state.

The Function No. is incremented by 1 every time the Function button is pressed. After Function No. 9 is displayed, the number changes to "C" and then returns to "0".

Any error at initial processing (self-diagnosis) is displayed on the Operator Panel (Function No. Display).

						TITLE	fi-6140/fi-6240/fi-6130/fi-6230/fi-614PR Maintenance Manual		
08	July 27, 09	K.Okada	A.Miyoshi	I.Fujioka	Refer to Revision Record on page 2.	DRAW	No. P1PA03540-B0XX/6	CUST.	
07	Nov.12, 08	K.Okada	T.Anzai	I.Fujioka	Refer to Revision Record on page 2.				
06	Mar.10, 08	K.Okada	T.Anzai	I.Fujioka	Refer to Revision Record on page 2.				
Rev.	DATE	DESIGN	CHECK	APPR.	DESCRIPTION	PFU LIMITED		Page	47 / 257
Design	July 27, 2007	K.Okada	CHECK	K.Okada		APPR.	T.Anzai		

4-2 Temporary errors and Alarm detection algorithm

4-2-1 Temporary errors

Temporary errors occur during scanning operation and can be remedied by an operator. The temporary errors are displayed on the PC screen through the driver and/or on the operator panel.

When a temporary error occurs, the scanner displays the following:

Function No. Display	Power LED	Description (supplement)
	ON	Displays “U” or “J” and the error No. (0~8) alternately. Example) When error “U0” occurs, the scanner displays the following: “U”→”SP”→”0” The interval of changing the display is approximately 0.5 second.

When **Scan** or **Send to** button is pressed while the alarm is displayed, the scanner returns to the “Ready” display (Function number display).

4-2-2 Alarms

Alarms require the maintenance conducted by an authorized service person. The following table shows the display and detection algorithm for alarms. The alarms are displayed on a PC screen and/or on the operator panel (Function No. Display).

When an alarm occurs, the scanner displays the following on the operator panel:

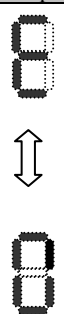
Function No. Display	Power LED	Description (supplement)
	ON	Displays “A”, “C”, “E”, “F”, “H”, or “L” and one of the alarms (0 ~ 9) alternately. The example shown in the left column is the case of Alarm “E0”. The display sequence is: “E” →”SP”→”0” The interval of changing the display is approximately 0.5 second.

When **Scan** or **Send to** button is pressed while the alarm is displayed, the scanner returns to the “Ready” display (Function number display).

4-2-3 Error Recovery Guide

If the application “Error Recovery Guide” (step (11) of Section 2.2.2) is installed in the PC, the corresponding error name and error code are displayed on the PC screen when any error or scanner alarm comes up.

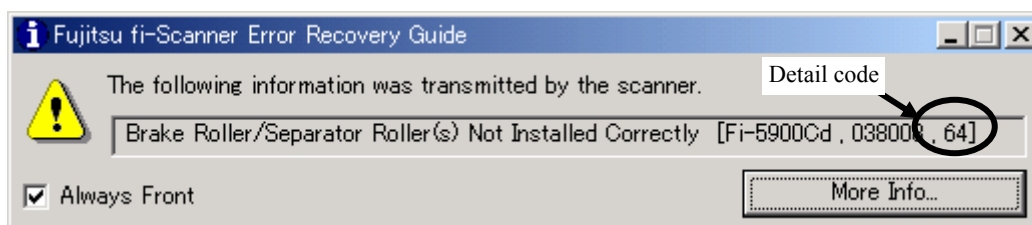

						TITLE	fi-6140/fi-6240/fi-6130/fi-6230/fi-614PR Maintenance Manual		
08	July 27, 09	K.Okada	A.Miyoshi	I.Fujioka	Refer to Revision Record on page 2.	DRAW No.	P1PA03540-B0XX/6		CUST.
07	Nov.12, 08	K.Okada	T.Anzai	I.Fujioka	Refer to Revision Record on page 2.				
06	Mar.10, 08	K.Okada	T.Anzai	I.Fujioka	Refer to Revision Record on page 2.				
Rev.	DATE	DESIGN	CHECK	APPR.	DESCRIPTION	PFU LIMITED		Page	48 / 257
Design	July 27, 2007	K.Okada	CHECK	K.Okada		APPR.	T.Anzai		

4-3 Troubleshooting

When a temporary error or an alarm occurs, find the troubleshooting procedure from the list in this section and go to the related section for maintenance. Before starting the troubleshooting, get the following information from your customer to understand whether the error is scanner-related or system-related.

- Is the scanner operated correctly?
- Are the fault symptoms reproducible or persistent?

(Check if the target scanner causes the same error under other systems.)

Following lists the case of troubleshooting described later in this section.

[Scanner Section]

Error category	Error description	Related section	Error Recovery Guide message 02
Device	Scanner is not turned ON. (Display of the operator panel goes out)	4-3-1	---
	Scanning does not start.	4-3-2	---
	Scanned image is distorted.	4-3-3	---
Image	Resolution is not satisfactory or tone error is too large.	4-3-4	---
	Too much jitter on scanned image with FB scanning	4-3-5	---
	Scanned image is misaligned with FB scanning	4-3-6	---
	Scan magnification factor abnormal with FB scanning	4-3-7	---
	Too much jitter on scanned image with ADF scanning	4-3-8	---
	Scanned image is misaligned with ADF scanning	4-3-9	---
	Scan magnification factor abnormal with ADF scanning	4-3-10	---
	Vertical streaks appear in scanned image	4-3-11	---
	When calibrating white level of scanned image	4-3-12	---
Temporary error	Frequent "J0: Paper jam error" 06	4-3-41	Stopped Scanning to prevent paper damage 038001 51 06
	Frequent "J1: Paper jam error" at scanner section	4-3-13	Document jam 038001 31 038001 50
	Frequent "J2: Multi feed error"	4-3-14	Multifeed Detected (Length) 038007 56 Multifeed Detected (Overlap) 038007 55
	Error detection of "U4: Scanner cover open"	4-3-15	ADF cover opened 038002 40
	Error detection of "No paper on the ADF paper chute (Chuter Unit)"	4-3-16	No Document in Hopper 038003 20
Scanner alarm	Frequent "U0: Shipping lock error"	4-3-17	Shipping lock malfunction 048005 10
	Frequent "E0: Carrier drive alarm"		Flatbed motor malfunction 048005 87
	"E1: Optical alarm (FB)"	4-3-18	Optical error (Flatbed) 048006 7E
	"E2: Optical alarm (ADF front)"		Optical error (ADF Front) 048006 74
	"E3: Optical alarm (ADF back)"		Optical error (ADF Back) 048006 75
	"E6: Operator panel alarm"	4-3-19	---
	"E7: EEPROM alarm"	4-3-20	EEPROM error 044400 D2
	"E8: SCSI alarm"	4-3-21	---
	"E9: Image memory alarm"	4-3-22	Memory malfunction 044400 E4
	"F4: Background changeover unit alarm"	4-3-23	Background changeover unit failure 048005 C2 (Front)
			Background changeover unit failure 048005 C3 (Back)
	"C0: LSI alarm"	4-3-24	LSI malfunction 044400 nn
	"H0: Motor alarm"	4-3-25	Fuse for ADF motor blown 048004 nn
	"H8: Motor alarm"		
	"H7: Lamp alarm"	4-3-26	Lamp fuse malfunction 048003 84
	"L6: US sensor alarm"	4-3-27	Sensor malfunction 044400 nn
"F: ROM sum check alarm"	4-3-28	---	
	Driver error	4-3-29	---

Rev.	DATE	DESIGN	CHECK	APPR.	DESCRIPTION	TITLE	fi-6140/fi-6240/fi-6130/fi-6230/fi-614PR	
08	July 27, 09	K.Okada	A.Miyoshi	I.Fujioka	Refer to Revision Record on page 2.	DRAW No.	Maintenance Manual	
07	Nov.12, 08	K.Okada	T.Anzai	I.Fujioka	Refer to Revision Record on page 2.		P1PA03540-B0XX/6	CUST.
06	Mar.10, 08	K.Okada	T.Anzai	I.Fujioka	Refer to Revision Record on page 2.			
Design	July 27, 2007	K.Okada	CHECK	K.Okada	APPR.	T.Anzai	PFU LIMITED	Page 49 / 257

Error category	Error description	Related section	Error Recovery Guide message 02
	“Abnormal command”	4-3-30	Invalid command 052000 nn Invalid CDB field 052400 nn Unsupported logical unit (LUN) 052500 nn Invalid field parameter list 052600 nn Command sequence error 052C00 nn Wrong windows combination 052C02 nn
Scanner alarm (cont'd)	“Interface alarm”	4-3-31	Message error 0B4300 nn Select/Reselect Failure 0B4500 nn SCSI parity error 0B4700 nn Initiator Detected Error Message Received 0B4800 nn Overlapped Command Attempted 0B4E00 nn Image transfer error 0B8001 nn

[Imprinter section]

Error category	Error description	Related section	Error Recovery Guide message
Temporary error	Frequent “J1: Paper jam” error at Imprinter	4-3-32	Document jam 038001 5A
	Error detection of “U5: Imprinter cover open”	4-3-33	ADF cover opened 038002 4A
Imprinter (option)	Imprinter does not initially operate	4-3-34	---
	“U6: No print cartridge”	4-3-35	Print cartridge not installed (Post-Imprinter) 038010 B4
	“H6: Imprinter fuse blown”	4-3-36	Imprinter fuse malfunction 048011 B1
	“A0: Imprinter control board alarm”	4-3-37	Post-Imprinter Error (RAM) 048010 B2
	“A1: Imprinter communication timeout”		Post-Imprinter Error (Communication Timed Out) 048010 B3
	“A2: Ink head alarm”		Post-Imprinter Error (Printer head) 048010 B5
	“A3: Imprinter EEPROM alarm”		Post-Imprinter Error (EEPROM) 048010 B6
	“A4: Imprinter ROM alarm”	4-3-37	Post-Imprinter Error (ROM) 048010 B8
	No printing / Printed letters are distorted	4-3-38	---
	Print form is dirty	4-3-39	---
Printing is interrupted in process	4-3-40	---	

						TITLE	fi-6140/fi-6240/fi-6130/fi-6230/fi-614PR Maintenance Manual		
08	July 27, 09	K.Okada	A.Miyoshi	I.Fujioka	Refer to Revision Record on page 2.	DRAW No.	P1PA03540-B0XX/6	CUST.	
07	Nov.12, 08	K.Okada	T.Anzai	I.Fujioka	Refer to Revision Record on page 2.				
06	Mar.10, 08	K.Okada	T.Anzai	I.Fujioka	Refer to Revision Record on page 2.				
Rev.	DATE	DESIGN	CHECK	APPR.	DESCRIPTION	PFU LIMITED		Page	50 / 257
Design	July 27, 2007	K.Okada	CHECK	K.Okada		APPR.	T.Anzai		

How to Troubleshoot:

- ◇ The troubleshooting should be conducted from item number 1 to the last item number in each table. Continue the troubleshooting until the error is corrected.

4-3-1 Scanner is not turned ON (Display of the operator panel goes out)

Table 4-3-1

Item No.	Check items	How/where to check
1	Does the same symptom occur after turning OFF and ON the scanner?	Press power button of the scanner for more than 2 seconds to turn it OFF, and after more than 2 seconds elapse, press the power button to turn the scanner ON.
	Are the AC cable and AC Adapter correctly connected?	---
2	Replace the AC cable and AC Adapter and see if the error is resolved.	---
3	Replace Panel PCA and see if the error is resolved.	Refer to Section 5-10-9.
4	Replace Control PCA and see if the error is resolved.	Refer to Section 5-11.

4-3-2 Scanning does not start

Table 4-3-2

Item No.	Check items	How/where to check
1	Does the same symptom appear when turning the scanner ON again?	Press power button of the scanner for more than 2 seconds to turn it OFF, and after more than 2 seconds elapse, press the power button to turn the scanner ON.
2	Check the items listed in the right column.	<ul style="list-style-type: none"> • Are the AC cable and AC Adapter correctly connected? • Is there documents loaded on ADF paper chute (Chuter Unit)? • Is ADF cover completely closed? • Is interface cable correctly connected? • Is SCSI ID correctly set? • If any temporary error or alarm is indicated, follow the corresponding troubleshooting.

4-3-3 Scanned image is distorted

Due to loose connection of connectors, cut wire in cables or defective parts, scanned image may have regular or random pattern distortion on it.

Table 4-3-3

Item No.	Check items	How/where to check
1	Check the items listed in the right column.	<ul style="list-style-type: none"> • Is interface cable correctly connected? • If any temporary error or alarm is indicated, follow the corresponding troubleshooting.
2	Are the cables between Control PCA and Optical Unit damaged? Or are the connectors connected correctly?	ADF front scanning: See Section 5-9-6 for checking. ADF back scanning: See Section 5-10-4 for checking. FB scanning: See Section 5-12-5 for checking.
3	Replace Optical Unit and see if the error is resolved.	ADF front scanning: See Section 5-9-6 for replacement. ADF back scanning: See Section 5-10-4 for replacement. FB scanning: See Section 5-12-5 for replacement.
4	Replace Control PCA and see if the error is resolved.	Refer to Section 5-11.

						TITLE	fi-6140/fi-6240/fi-6130/fi-6230/fi-614PR Maintenance Manual		
08	July 27, 09	K.Okada	A.Miyoshi	I.Fujioka	Refer to Revision Record on page 2.	DRAW	P1PA03540-B0XX/6	CUST.	
07	Nov.12, 08	K.Okada	T.Anzai	I.Fujioka	Refer to Revision Record on page 2.	No.			
06	Mar.10, 08	K.Okada	T.Anzai	I.Fujioka	Refer to Revision Record on page 2.				
Rev.	DATE	DESIGN	CHECK	APPR.	DESCRIPTION	PFU LIMITED		Page	51 / 257
Design	July 27, 2007	K.Okada	CHECK	K.Okada		APPR.	T.Anzai		

4-3-4 Resolution is not satisfactory or tone error is too large

Table 4-3-4

Item No.	Check items	How/where to check
1	Check the items listed in the right column.	<ul style="list-style-type: none"> Does the document satisfy the paper specifications described in Section 1-1-6? Are the scan settings correctly specified for the application software used? Is interface cable correctly connected? If any temporary error or alarm is indicated, follow the corresponding troubleshooting.
2	Clean feed rollers, Eject rollers, plastic rollers and glass surface, and check whether the error is resolved.	Refer to Section 7-2-1 "Cleaning the ADF."
3	Is the OPT Unit or Lamp dirty? Are the cables damaged? Or are the connectors connected correctly?	See Section 5-3-1 for cleaning/checking.
4	Is the OPT Unit for this scanner installed?	ADF front scanning: See Section 5-9-6 for removal. ADF back scanning: See Section 5-10-4 for removal. FB scanning: See Section 5-12-5 for removal.
5	Replace OPT Unit and see if the error is resolved.	ADF front scanning: See Section 5-9-6 for replacement. ADF back scanning: See Section 5-10-4 for replacement. FB scanning: See Section 5-12-5 for replacement.
6	Replace Control PCA and see if the error is resolved.	Refer to Section 5-11.

4-3-5 Too much jitter on scanned image with FB scanning fi-6240/fi-6230

The following shows the sample of scanned image when "Jitter" error occurs. This error occurs when the carrier unit does not move smoothly.

Scanned image with jitter

ABCDEF G

Normal scanned image

ABCDEF G

Table 4-3-5

Item No.	Check items	How/where to check
1	Check the items listed in the right column.	<ul style="list-style-type: none"> Any shock given to the scanner during operation? Is the scanner placed on a level surface?
2	Does any foreign object get inside and prevent Carrier unit from moving?	Remove FB top cover for checking by referring to Section 5-12-1.
3	Is CR belt tension loose?	Refer to a note of procedure (2) of Section 5-5 for checking.
4	Is the OPT Unit correctly installed?	Refer to Section 5-12-5.
5	Replace FB Motor and see if the error is resolved.	Refer to Section 5-12-3 for checking.
6	Replace Control PCA and see if the error is resolved.	Refer to Section 5-11.

						TITLE	fi-6140/fi-6240/fi-6130/fi-6230/fi-614PR Maintenance Manual		
08	July 27, 09	K.Okada	A.Miyoshi	I.Fujioka	Refer to Revision Record on page 2.	DRAW No.	P1PA03540-B0XX/6	CUST.	
07	Nov.12, 08	K.Okada	T.Anzai	I.Fujioka	Refer to Revision Record on page 2.				
06	Mar.10, 08	K.Okada	T.Anzai	I.Fujioka	Refer to Revision Record on page 2.				
Rev.	DATE	DESIGN	CHECK	APPR.	DESCRIPTION	PFU LIMITED		Page	52 / 257
Design	July 27, 2007	K.Okada	CHECK	K.Okada		APPR.	T.Anzai		

4-3-6 Scanned image is misaligned with FB scanning **fi-6240/fi-6230**

Table 4-3-6

Item No.	Check items	How/where to check
1	Check the items listed in the right column.	<ul style="list-style-type: none"> Any shock given to the scanner during operation? Is the scanner placed on a level surface? Are the scan settings correct for the application software used?
2	Is the document aligned to the reference point on the document bed?	Refer to Section 7-1-3 "Loading Documents on the Flatbed for Scanning..
3	Adjust the offset by Maintenance mode.	Refer to Section 6-1-4.
4	Is FB top cover installed correctly?	Refer to procedure (1) ~ (5) in Section 5-12-1.
5	Is the OPT Unit installed correctly?	Refer to Section 5-12-5 for removal.
6	Replace OPT Unit in FB and see if the error is resolved.	Refer to Section 5-12-5.

4-3-7 Scan magnification factor abnormal with FB scanning **fi-6240/fi-6230**

Table 4-3-7

Item No.	Check items	How/where to check
1	Check the items listed in the right column.	<ul style="list-style-type: none"> Any shock given to the scanner during operation? Is the scanner placed on a level surface? Are the scan settings correct for the application software used?
2	Does the abnormal magnification occur horizontally (main scanning direction) or vertically (sub scanning direction)?	Main scanning direction: Go to Item No.3. Sub scanning direction Go to Item No.7.
3	Adjust the magnification by Maintenance mode.	Refer to Section 6-1-3.
4	Does any foreign object get inside and prevent Carrier unit from moving?	Remove FB cover for checking by referring to Section 5-12-1.
5	Is CR belt tension loose?	Refer to a notice of (2) in Section 5-5 for checking.
6	Replace FB Motor and see if the error is resolved.	Refer to Section 5-12-3. If FB Motor is OK, go to item No. 9.
7	Is the OPT Unit installed correctly?	Refer to Section 5-12-5 for removal.
8	Replace the OPT Unit and see if the error is resolved.	Refer to Section 5-12-5.
9	Replace Control PCA and see if the error is resolved.	Refer to Section 5-11.

						TITLE	fi-6140/fi-6240/fi-6130/fi-6230/fi-614PR Maintenance Manual		
08	July 27, 09	K.Okada	A.Miyoshi	I.Fujioka	Refer to Revision Record on page 2.	DRAW No.	P1PA03540-B0XX/6	CUST.	
07	Nov.12, 08	K.Okada	T.Anzai	I.Fujioka	Refer to Revision Record on page 2.				
06	Mar.10, 08	K.Okada	T.Anzai	I.Fujioka	Refer to Revision Record on page 2.				
Rev.	DATE	DESIGN	CHECK	APPR.	DESCRIPTION	PFU LIMITED		Page	53 / 257
Design	July 27, 2007	K.Okada	CHECK	K.Okada		APPR.	T.Anzai		

4-3-8 Too much jitter on scanned image with ADF scanning

The following shows the sample of scanned image when “Jitter” error occurs. This error occurs when the ADF feed roller does not transport the document smoothly.

Scanned image with jitter

ABCDEF G

Normal scanned image

ABCDEF G

Table 4-3-8

Item No.	Check items	How/where to check
1	Does the document satisfy the paper specification?	Refer to Section 1-1-6.
2	Clean Feed rollers, Eject rollers, plastic rollers, glass surface and paper feeding surface, and see if the error is resolved.	Refer to Section 7-2-1 “Cleaning ADF”.
3	Replace Pick roller or Brake roller and see if the error is resolved.	Check the consumable counter from the TWAIN driver screen or in the built-in Maintenance mode. When the counter exceeds the values shown in Section 7-3-1, replace Pick roller or Brake roller.
4	Are the Guide P ASSY (Sheet Guide) and Feed roller cover (plate guide) installed correctly?	Guide P ASSY (Sheet Guide): Refer to Section 5-9-8. Feed roller cover (plate guide): Refer to Section 5-10-7.
5	Are the belt tensions of PICK Motor or ADF Motor appropriate?	PICK Motor: Refer to Section 5-9-10. ADF Motor: Refer to Section 5-10-3.
6	Are the cables between Control PCA and PICK Motor or ADF Motor damaged? Are the connectors connected correctly?	PICK Motor: Refer to Section 5-9-10. ADF Motor: Refer to Section 5-10-3.
7	Are the OPT Units installed correctly?	ADF front scanning: Refer to Section 5-9-6 for removal. ADF back scanning: Refer to Section 5-10-4 for removal.
8	Replace PICK Motor or ADF Motor and see if the error is resolved.	PICK Motor: Refer to Section 5-9-10. ADF Motor: Refer to Section 5-10-3.
9	Replace Upper Unit and see if the error is resolved.	Refer to Section 5-10-1.
10	Replace Base Unit and see if the error is resolved.	Refer to Section 5-9-1.

						TITLE	fi-6140/fi-6240/fi-6130/fi-6230/fi-614PR Maintenance Manual		
08	July 27, 09	K.Okada	A.Miyoshi	I.Fujioka	Refer to Revision Record on page 2.	DRAW No.	P1PA03540-B0XX/6	CUST.	
07	Nov.12, 08	K.Okada	T.Anzai	I.Fujioka	Refer to Revision Record on page 2.				
06	Mar.10, 08	K.Okada	T.Anzai	I.Fujioka	Refer to Revision Record on page 2.				
Rev.	DATE	DESIGN	CHECK	APPR.	DESCRIPTION	PFU LIMITED		Page	54 / 257
Design	July 27, 2007	K.Okada	CHECK	K.Okada		APPR.	T.Anzai		

4-3-9 Scanned image is misaligned with ADF scanning

Table 4-3-9

Item No.	Check items	How/where to check
1	Check the items listed in the right column.	- Does the document satisfy the paper specifications described in Section 1-1-6? - Are the scan settings correct for the application software used?
2	Clean feed rollers, Eject rollers and plastic roller and see if the error is resolved.	Refer to Section 7-2-1.
3	Adjust the offset by Maintenance mode.	Refer to Section 6-1-4.
4	Check the Pick roller and Brake roller counter to see if they need to be replaced.	Refer to Section 6-1-6 "Maintenance mode #5: Consumable counter display and reset" and Section 7-3-1 "Consumables."
5	Is the OPT Unit installed correctly?	ADF (front) scanning: Refer to Section 5-9-6.
6	Replace the OPT Unit and see if the error is resolved.	ADF (back) scanning: Refer to Section 5-10-4.
7	When the backside image is misaligned, replace Upper Unit and see whether the error is resolved.	Refer to Section 5-10-1.
8	When the front side image is misaligned, replace Base Unit and see whether the error is resolved.	Refer to Section 5-9-1.

4-3-10 Scan magnification factor abnormal with ADF scanning

Table 4-3-10

Item No.	Check items	How/where to check
1	Check the items listed in the right column.	Are the scan settings correct for the application software used?
2	Adjust the magnification in Maintenance mode.	Refer to Section 6-1-3. When main scanning magnification is abnormal: Go to Item No.3 When sub-scanning magnification is abnormal: Go to Item No.8
3	Clean feed rollers roller and plastic roller and see if the error is resolved.	Refer to Section 7-2-1.
4	Does any foreign object get inside Upper Unit and disturb transporting operation by feed rollers?	Open the ADF and check Upper Unit gear.
5	Check the Pick roller and Brake roller counter to see if they need to be replaced.	Refer to Section 6-1-6 "Maintenance mode #5: Consumable counter display and reset" and Section 7-3-1 "Consumables."
6	Is the ADF Motor belt loose?	Refer to Section 5-10-3.
7	Replace the ADF Motor and see whether the error is resolved.	Refer to Section 5-10-3.
8	Is the OPT Unit installed correctly?	ADF (front) scanning: Refer to Section 5-9-6.
9	Replace the OPT Unit and see whether the error is resolved.	ADF (back) scanning: Refer to Section 5-10-4.

						TITLE	fi-6140/fi-6240/fi-6130/fi-6230/fi-614PR Maintenance Manual		
08	July 27, 09	K.Okada	A.Miyoshi	I.Fujioka	Refer to Revision Record on page 2.	DRAW	P1PA03540-B0XX/6	CUST.	
07	Nov.12, 08	K.Okada	T.Anzai	I.Fujioka	Refer to Revision Record on page 2.	No.			
06	Mar.10, 08	K.Okada	T.Anzai	I.Fujioka	Refer to Revision Record on page 2.				
Rev.	DATE	DESIGN	CHECK	APPR.	DESCRIPTION	PFU LIMITED		Page	55 / 257
Design	July 27, 2007	K.Okada	CHECK	K.Okada		APPR.	T.Anzai		

4-3-11 Vertical streaks appear in scanned image

Table 4-3-11

Item No.	Check items	How/where to check
1	Check the items listed in the right column.	<ul style="list-style-type: none"> Are the scan settings correctly specified for the application software used? Is interface cable correctly connected?
2	Clean glass in the ADF and see if the error is resolved.	Refer to Section 7-2-1.
3	When the error occurs on ADF front, clean the glass inside of Base Unit. When the error occurs on ADF back, clean the glass of the Upper Unit. 07 If glasses inside of the Units cannot be cleaned, replace the Base Unit/Upper Unit. When the error occurs on FB, clean inside of the glass of the FB.	Glass inside of Base Unit: Refer to Section 5-3-2. Glass inside of Upper Unit: Refer to Section 5-3-3. Glass inside of FB: Refer to Section 5-3-4. Base Unit replacement: Section 5-9-1 Upper Unit replacement: Section 5-10-1
4	Does any dirt get on the white reference sheet?	Base Unit: Refer to Section 5-3-5 Upper Unit: Refer to Section 5-3-6
5	Is the mirror of the OPT Unit dirty? Are cables damaged? Are connectors connected correctly?	ADF (front/back)/ FB: Refer to Section 5-3-1.
6	Replace the OPT Unit and see if the error is resolved.	ADF front: Refer to Section 5-9-6 for replacement procedure. ADF back: Refer to Section 5-10-4 for replacement procedure. FB: Refer to Section 5-12-5 for replacement procedure.
7	Replace Control PCA and see if the error is resolved.	Refer to Section 5-11.

4-3-12 When calibrating white of scanned image

Table 4-3-12

Item No.	Check items	How/where to check
1	Check the items listed in the right column.	<ul style="list-style-type: none"> Are the scan settings correct for the application software used? Are the white reference and glass in the ADF dirty?
2	Conduct the white adjustment by Maintenance mode.	Refer to Section 6-1-5.

08	July 27, 09	K.Okada	A.Miyoshi	I.Fujioka	Refer to Revision Record on page 2.	TITLE	fi-6140/fi-6240/fi-6130/fi-6230/fi-614PR Maintenance Manual		
07	Nov.12, 08	K.Okada	T.Anzai	I.Fujioka	Refer to Revision Record on page 2.	DRAW No.	P1PA03540-B0XX/6	CUST.	
06	Mar.10, 08	K.Okada	T.Anzai	I.Fujioka	Refer to Revision Record on page 2.				
Rev.	DATE	DESIGN	CHECK	APPR.	DESCRIPTION	PFU LIMITED		Page	56 / 257
Design	July 27, 2007	K.Okada	CHECK	K.Okada		APPR.	T.Anzai		

4-3-13 Frequent “J1: paper jam” error at scanner section

(ERG: Document jam 038001 31, 038001 50)

Table 4-3-13

Item No.	Check items	How/where to check
1	Do the documents satisfy paper specification?	Refer to Section 1-1-6 for paper specification.
2	Have the documents been jogged?	<ul style="list-style-type: none"> Align the edge of documents for stable paper feeding. Remove documents with crease or dog-ear. Scanning different width of documents may cause skew and result in paper jam.
3	Are Chuter Unit (ADF paper chute), Guide P ASSY (Sheet guide), Feed roller cover (plate guide) and Brake roller cover installed correctly?	Chuter Unit (ADF paper chute): Refer to Section 5-8-1 Guide P ASSY (Sheet guide): Refer to Section 5-9-8. Feed roller cover (plate guide): Refer to Section 5-10-7. Brake roller cover: Refer to Section 7-3-3.
4	Clean the Feed rollers, Eject rollers, Plastic rollers, glass surface and paper feeding surface, and see if the error is resolved.	Refer to Section 7-2-1 “Cleaning the ADF.”
5	Replace Pick roller or Brake roller, and see if the error is resolved.	Check the consumable counter from the TWAIN driver screen or from the built-in Maintenance mode. When the counter exceeds the values shown in Section 7-3-1, replace Pick roller or Brake roller.
6	Is the Pick roller rotating? If not rotating, then replace the PICK Motor.	Referring to Section 6-1-2, perform the paper feeding test. PICK Motor: Refer to Section 5-9-10.
7	Check the performance of PICK sensor or TOP sensor. If not operating, then replace the sensor.	Referring to Section 6-1-2, perform the sensor test. Refer to Section 6-2 “Saving EEPROM data” for the sensor installation position. PICK sensor/TOP sensor: Refer to Section 5-9-5.
8	Check the performance of the Cover Open Sensor. If not operating, then replace the sensor.	Referring to Section 6-1-2, perform the sensor test. Refer to Section 6-2 “Saving EEPROM data” for the sensor installation position. Cover open sensor: Refer to Section 5-9-12.
9	Check if the Paper protection roller rotates and moves up and down smoothly. If not operating, then replace the Base Unit.	Refer to Section 6-2 “Saving EEPROM data” for the installation position of the Paper protection roller. Base Unit: Refer to Section 5-9-1.
10	Replace the Control PCA and see if the error is resolved.	Refer to Section 5-11.

						TITLE	fi-6140/fi-6240/fi-6130/fi-6230/fi-614PR Maintenance Manual		
08	July 27, 09	K.Okada	A.Miyoshi	I.Fujioka	Refer to Revision Record on page 2.	DRAW	No.	P1PA03540-B0XX/6	CUST.
07	Nov.12, 08	K.Okada	T.Anzai	I.Fujioka	Refer to Revision Record on page 2.				
06	Mar.10, 08	K.Okada	T.Anzai	I.Fujioka	Refer to Revision Record on page 2.				
Rev.	DATE	DESIGN	CHECK	APPR.	DESCRIPTION	PFU LIMITED		Page	57 / 257
Design	July 27, 2007	K.Okada	CHECK	K.Okada		APPR.	T.Anzai		

4-3-14 Frequent “J2: multi feed error”

Table 4-3-14

Item No.	Check items	How/where to check
1	Do the documents satisfy paper specification?	Refer to Section 1-1-6 and 1-1-7 for paper specification, paying attention to the following points: <ul style="list-style-type: none"> Is multi feed error detected by paper length when scanning documents with different length? Is there perforation in the center of documents?
2	Clean ADF unit.	Refer to Section 7-2-1 for cleaning cycle and method. Clean the area around the Pick roller, Brake roller and US Sensor with care.
3	Replace Pick roller or Brake roller and see if the error is resolved.	Check the consumable counter from the TWAIN driver screen or from the built-in Maintenance mode. When the counter exceeds the values shown in Section 7-3-1, replace Pick roller or Brake roller.
4	Check the performance of US Sensor.	Referring to Section 6-1-2, perform the sensor test. Refer to Section 6-2 “Saving EEPROM data” for the US sensor installation position. If the sensor does not operate, check is the sensor cable is correctly connected, replace the US Sensor FX and then US Sensor RV. (Refer to Sections 5-9-5 “US Sensor FX (Multifeed detection)” and Section 5-10-7 “US Sensor RV (Multifeed detection).”)

4-3-15 Error detection of “U4: Scanner Cover open”

(ERG: ADF cover opened 038002 40)

Table 4-3-15

Item No.	Check items	How/where to check
1	Does the same symptom occur after turning OFF and ON the scanner?	Press power button of the scanner for more than 2 seconds to turn it OFF, and after more than 2 seconds elapse, press the power button to turn the scanner ON.
2	Is there a slip of paper left near Cover Open Sensor?	Open the ADF and check inside visually. Refer to Section 6-2 “Saving EEPROM data” for the Cover Open sensor installation position.
3	Check the performance of Cover Open Sensor.	Referring to Section 6-1-2, perform the sensor test and check if the Cover open sensor operates properly. Refer to Section 6-2 “Saving EEPROM data” for the Cover Open sensor installation position. If the sensor does not operate properly, check if the sensor cable is correctly connected. If the sensor is defective, replace the Base Unit. (Refer to Section 5-9-1 “Base Unit.”)

With the Imprinter installed:

4-3-16 Error detection of “No paper on the ADF paper chute (Chuter Unit)”

Table 4-3-16

Item No.	Check items	How/where to check
1	Does the same symptom occur after turning OFF and ON the scanner?	Press power button of the scanner for more than 2 seconds to turn it OFF, and after more than 2 seconds elapse, press the power button to turn the scanner ON.
2	Is there a slip of paper left near the Empty sensor?	Open the ADF and check inside visually. Refer to Section 6-2 “Saving EEPROM data” for the sensor installation position.
3	Check the performance of the Empty sensor.	Referring to Section 6-1-2, perform the sensor test. If the sensor does not operate, check if the sensor cable is correctly connected, then replace the Sensor EMP. (Refer to Section 5-10-8.)

Rev.	DATE	DESIGN	CHECK	APPR.	DESCRIPTION	TITLE	DRAW No.		CUST.
08	July 27, 09	K.Okada	A.Miyoshi	I.Fujioka	Refer to Revision Record on page 2.	fi-6140/fi-6240/fi-6130/fi-6230/fi-614PR Maintenance Manual	P1PA03540-B0XX/6		CUST.
07	Nov.12, 08	K.Okada	T.Anzai	I.Fujioka	Refer to Revision Record on page 2.				
06	Mar.10, 08	K.Okada	T.Anzai	I.Fujioka	Refer to Revision Record on page 2.				
						PFU LIMITED	Page	58 / 257	
Design	July 27, 2007	K.Okada	CHECK	K.Okada			APPR.	T.Anzai	

4-3-17 Frequent “U0: Shipping lock error” or “E0: Carrier drive alarm”

Table 4-3-17

Item No.	Check items	How/where to check
1	Does the same symptom occur after turning OFF and ON the scanner?	Press power button of the scanner for more than 2 seconds to turn it OFF, and after more than 2 seconds elapse, press the power button to turn the scanner ON.
2	Does the same symptom occur after unlocking the Shipping lock?	Refer to Section 2-2-2.
3	Is there abnormal noise from the FB Motor when this error occurs?	If abnormal noise is heard, go to item No.4. If there is no abnormal noise, go to item No.5 to check sensors or drive unit.
4	Does any foreign object get inside drive unit or carrier unit?	Check visually.
5	Is the Joint PCA connected correctly?	Refer to Section 5-12-10 for removal.
6	Replace the Joint PCA and see if the error is resolved.	Refer to Section 5-12-10.
7	Is the CR Belt tension loose?	Refer to a note of (2) of Section 5-5 for checking. Loose belt should be tightened.
8	Is the FB Motor cable connected?	Connect it if disconnected.
9	Replace the Control PCA and see if the error is resolved.	Refer to Section 5-11.

4-3-18 “E1/E2/E3: Optical alarm”

Table 4-3-18

Item No.	Check items	How/where to check
1	Does the same symptom occur after turning OFF and ON the scanner?	Press power button of the scanner for more than 2 seconds to turn it OFF, and after more than 2 seconds elapse, press the power button to turn the scanner ON.
2	When E2 or E3 error occurs, check if the glass in the reading position dirty	Open the ADF and clean the glass. (Refer to Section 7-2-1.)
3	Is the Lamp ON? Are the cables between the Lamp and Inverter damaged? Are the connectors connected correctly?	Open the ADF and press the Cover open sensor to light the Lamp. If the Lamp does not light, replace the Lamp, and then Inverter. E1 (FB): Refer to Sections 5-12-7, 5-12-6 E2 (ADF front): Refer to Sections 5-9-4, 5-9-3 E3 (ADF back): Refer to Section 5-10-6, 5-10-5. Refer to Section 6-2 “Saving EEPROM data” for the Cover Open sensor installation position.
4	Is the OPT Unit dirty? Is the CCD cable damaged? Are the connectors connected correctly?	E1 (FB): Refer to Section 5-3-1 for cleaning/checking. Referring to Section 5-12-8, check if the CR cable is damaged. E2 (ADF front): Refer to Section 5-3-1 for cleaning/checking. E3 (ADF back): Refer to Section 5-3-1 for cleaning/checking.
5	When the error is E2 (ADF front), check if the glass and white reference sheet inside of the Base Unit are dirty.	White reference sheet inside of the Base Unit: Section 5-3-5.
6	When the error is E3 (ADF back), check if the glass and white reference sheet inside of the Upper Unit are dirty.	White reference sheet inside of the Upper Unit: Section 5-3-6.
7	Replace OPT Unit and see if the error is resolved.	E1 (FB): Refer to Section 5-12-5. E2 (ADF front): Refer to Section 5-9-6. E3 (ADF back): Refer to Section 5-10-4.
8	Replace the Control PCA and see if the error is resolved.	Refer to Section 5-11.

08	July 27, 09	K.Okada	A.Miyoshi	I.Fujioka	Refer to Revision Record on page 2.	TITLE	fi-6140/fi-6240/fi-6130/fi-6230/fi-614PR Maintenance Manual		
07	Nov.12, 08	K.Okada	T.Anzai	I.Fujioka	Refer to Revision Record on page 2.	DRAW No.	P1PA03540-B0XX/6		CUST.
06	Mar.10, 08	K.Okada	T.Anzai	I.Fujioka	Refer to Revision Record on page 2.				
Rev.	DATE	DESIGN	CHECK	APPR.	DESCRIPTION	PFU LIMITED		Page	59 / 257
Design	July 27, 2007	K.Okada	CHECK	K.Okada		APPR.	T.Anzai		

4-3-19 “E6: Operator panel alarm”

Table 4-3-19

Item No.	Check items	How/where to check
1	Does the same symptom occur after turning OFF and ON the scanner?	Press power button of the scanner for more than 2 seconds to turn it OFF, and after more than 2 seconds elapse, press the power button to turn the scanner ON.
2	Is the cable connected correctly?	Refer to Section 5-10-9 “Panel PCA.”
3	It seems the installed Panel PCA has been used in other scanner before and it may be faulty one. Replace it with the new Panel PCA.	Replace the Panel PCA with new one after saving the EEPROM data. Then conduct Maintenance mode #7 by referring to Section 6-1-8.

4-3-20 “E7: EEPROM alarm”

Table 4-3-20

Item No.	Check items	How/where to check
1	Does the same symptom occur after turning OFF and ON the scanner?	Press power button of the scanner for more than 2 seconds to turn it OFF, and after more than 2 seconds elapse, press the power button to turn the scanner ON.
2	Is the cable connected correctly?	Refer to Section 5-10-9 “Panel PCA.”
3	Replace the Panel PCA and see if the error is resolved.	Refer to Section 5-10-9 for replacement.
4	Replace the Control PCA and see if the error is resolved.	Refer to Section 5-11 for replacement.

4-3-21 “E8: SCSI alarm”

Table 4-3-21

Item No.	Check items	How/where to check
1	Does the same symptom occur after turning OFF and ON the scanner?	Press power button of the scanner for more than 2 seconds to turn it OFF, and after more than 2 seconds elapse, press the power button to turn the scanner ON.
2	Check if the SCSI cable or other SCSI devices connected to the scanner cause this error.	The scanner can work even after this error occurs. Go to item 3 if you want to remove this error.
3	Replace the Control PCA and see if the error is resolved.	Refer to Section 5-11 for replacement.

4-3-22 “E9: Image memory alarm”

Table 4-3-22

Item No.	Check items	How/where to check
1	Does the same symptom occur after turning OFF and ON the scanner?	Press power button of the scanner for more than 2 seconds to turn it OFF, and after more than 2 seconds elapse, press the power button to turn the scanner ON.
2	Replace the Control PCA and see if the error is resolved.	Refer to Section 5-11 for replacement.

08	July 27, 09	K.Okada	A.Miyoshi	I.Fujioka	Refer to Revision Record on page 2.	TITLE	fi-6140/fi-6240/fi-6130/fi-6230/fi-614PR Maintenance Manual		
07	Nov.12, 08	K.Okada	T.Anzai	I.Fujioka	Refer to Revision Record on page 2.	DRAW No.	P1PA03540-B0XX/6	CUST.	
06	Mar.10, 08	K.Okada	T.Anzai	I.Fujioka	Refer to Revision Record on page 2.				
Rev.	DATE	DESIGN	CHECK	APPR.	DESCRIPTION	PFU LIMITED		Page	60 / 257
Design	July 27, 2007	K.Okada	CHECK	K.Okada		APPR.	T.Anzai		

4-3-23 “F4: Background changeover unit alarm”

Table 4-3-23

Item No.	Check items	How/where to check
1	Does the same symptom occur after turning OFF and ON the scanner?	Press power button of the scanner for more than 2 seconds to turn it OFF, and after more than 2 seconds elapse, press the power button to turn the scanner ON.
2	Are the cables between the Control PCA and the BW Motor damaged? Or are the connectors connected correctly?	Refer to Section 5-9-7 for checking.
3	Is the white reference work properly? If not, then replace the BW Motor.	Refer to Section 6-1-2 for background changeover test. Refer to Section 5-9-7.
4	Is the OPT Unit installed correctly?	ADF (Front): Refer to Section 5-9-6. ADF (Back): Refer to Section 5-10-4. FB: Refer to Section 5-12-5.
5 08	Are the cables between the Control PCA and the Inverter, and the cables between the Lamp and Inverter damaged? Or are the connectors connected correctly?	ADF (Front): Refer to Section 5-9-3. ADF (Back): Refer to Section 5-10-5. FB: Refer to Section 5-12-6.
6 08	Is the Lamp ON? If not, replace the Inverter.	ADF (Front): Refer to Section 5-9-3. ADF (Back): Refer to Section 5-10-5. FB: Refer to Section 5-12-6.
7	Replace the Control PCA and see if the error is resolved.	Refer to Section 5-11.
8	Replace the OPT Unit and see if the error is resolved.	ADF (front) scanning: Refer to Section 5-9-6. ADF (back) scanning: Refer to Section 5-10-4. FB scanning: Refer to Section 5-12-5.

4-3-24 “C0: LSI alarm”

Table 4-3-24

Item No.	Check items	How/where to check
1	Does the same symptom occur after turning OFF and ON the scanner?	Press power button of the scanner for more than 2 seconds to turn it OFF, and after more than 2 seconds elapse, press the power button to turn the scanner ON.
2	Replace the Control PCA and see if the error is resolved.	Refer to Section 5-11 for replacement.

						TITLE	fi-6140/fi-6240/fi-6130/fi-6230/fi-614PR Maintenance Manual		
08	July 27, 09	K.Okada	A.Miyoshi	I.Fujioka	Refer to Revision Record on page 2.	DRAW	P1PA03540-B0XX/6	CUST.	
07	Nov.12, 08	K.Okada	T.Anzai	I.Fujioka	Refer to Revision Record on page 2.	No.			
06	Mar.10, 08	K.Okada	T.Anzai	I.Fujioka	Refer to Revision Record on page 2.				
Rev.	DATE	DESIGN	CHECK	APPR.	DESCRIPTION	PFU LIMITED		Page	61 / 257
Design	July 27, 2007	K.Okada	CHECK	K.Okada		APPR.	T.Anzai		

4-3-25 “H0/H8: Motor alarm”

Table 4-3-25

Item No.	Check items	How/where to check
1	Does the same symptom occur after turning OFF and ON the scanner?	Press power button of the scanner for more than 2 seconds to turn it OFF, and after more than 2 seconds elapse, press the power button to turn the scanner ON.
2	Does any foreign object get inside the Control PCA?	Take out the Control PCA for checking (Refer to Section 5-11).
3	Are the cables between Control PCA and the motor damaged? Or are the connectors connected correctly?	Refer to the following sections for checking the cables and connectors. ADF Motor: Refer to Section 5-10-3. PICK Motor: Refer to Section 5-9-10. FB Motor: Refer to Section 5-12-3. BW Motor: Refer to Section 5-9-7.
4	Is the coil resistance of the motor normal?	Remove the motor cable to check the coil resistance between the following pins of the motor. <H0> <u>ADF Motor</u> (1) Yellow – (2) Red, (3) Brown – (4) Orange Approx. 1 Ω Other matches Infinity <u>PICK Motor-</u> (1) Yellow – (2) Red. (3) Brown – (4) Orange Approx. 1.05 Ω Other matches Infinity <u>FB Motor</u> (1) Yellow – (2) Red, (3) Brown – (4) Orange Approx. 5 Ω Other matches Infinity <H8> <u>BW Motor</u> (1)Black-(2)Brown approx. 30 Ω ± 10% (3)Yellow-(4)Orange approx. 30 Ω ± 10% Other matches Infinity <div style="text-align: center;"> </div> Replace the motor if the resistance is abnormal. ADF Motor: Refer to Section 5-10-3. PICK Motor: Refer to Section 5-9-10. FB Motor: Refer to Section 5-12-3. BW Motor: Refer to Section 5-9-7.
5	Replace Control PCA and see if the error is resolved.	Refer to Section 5-11 for replacement.

08	July 27, 09	K.Okada	A.Miyoshi	I.Fujioka	Refer to Revision Record on page 2.	TITLE fi-6140/fi-6240/fi-6130/fi-6230/fi-614PR Maintenance Manual		
07	Nov.12, 08	K.Okada	T.Anzai	I.Fujioka	Refer to Revision Record on page 2.		DRAW No. P1PA03540-B0XX/6	CUST.
06	Mar.10, 08	K.Okada	T.Anzai	I.Fujioka	Refer to Revision Record on page 2.			
Rev.	DATE	DESIGN	CHECK	APPR.	DESCRIPTION	PFU LIMITED	Page	62 / 257
Design	July 27, 2007	K.Okada	CHECK	K.Okada	APPR.	T.Anzai		

4-3-26 “Lamp alarm”

Table 3-3-26

Item No.	Check items	How/where to check
1	Does the same symptom occur after turning OFF and ON the scanner?	Press power button of the scanner for more than 2 seconds to turn it OFF, and after more than 2 seconds elapse, press the power button to turn the scanner ON.
2	Does any foreign object get inside the Control PCA?	Take out the Control PCA for checking (Refer to Section 5-11).
3	Are the cables between Control PCA and the lamps damaged? Or are the connectors connected correctly?	Refer to the following sections for checking the cables and connectors. Lamp (ADF front): Refer to Section 5-9-4. Lamp (ADF back): Refer to Section 5-10-6. Lamp (FB): Refer to Section 5-12-7.
4	Replace the Control PCA and see if the error is resolved.	Refer to Section 5-11 for replacement.

4-3-27 “L6: US sensor alarm”

Table 4-3-27

Item No.	Check items	How/where to check
1	Does the same symptom occur after turning OFF and ON the scanner?	Press power button of the scanner for more than 2 seconds to turn it OFF, and after more than 2 seconds elapse, press the power button to turn the scanner ON.
2	Check the US Sensor operation.	Conduct Maintenance mode (refer to Section 6-1-2) to see if the US sensor works properly. If the error still occurs, confirm that the sensor cable is correctly connected. And then replace the US Sensor FX and US Sensor RV. (Refer to Sections 5-9-5 “US Sensor FX (Multifeed detection)” and Section 5-10-7 “US Sensor RV (Multifeed detection).”)

4-3-28 “F: ROM sum check alarm”

Table 4-3-28

Item No.	Check items	How/where to check
1	Does the same symptom occur after turning OFF and ON the scanner?	Press power button of the scanner for more than 2 seconds to turn it OFF, and after more than 2 seconds elapse, press the power button to turn the scanner ON.
2	Replace the Control PCA and see if the error is resolved.	Refer to Section 5-11 for replacement.

4-3-29 Driver error

Table 4-3-29

Item No.	Check items	How/where to check
1	Does the same symptom occur after turning OFF and ON the scanner?	Press power button of the scanner for more than 2 seconds to turn it OFF, and after more than 2 seconds elapse, press the power button to turn the scanner ON.
2	Is the connector between the scanner and the PC correctly connected?	Refer to Section 2-2-2.
3	Replace the Control PCA and see if the error is resolved.	Refer to Section 5-11 for replacement.

08	July 27, 09	K.Okada	A.Miyoshi	I.Fujioka	Refer to Revision Record on page 2.	TITLE	fi-6140/fi-6240/fi-6130/fi-6230/fi-614PR Maintenance Manual		
07	Nov.12, 08	K.Okada	T.Anzai	I.Fujioka	Refer to Revision Record on page 2.	DRAW No.	P1PA03540-B0XX/6		CUST.
06	Mar.10, 08	K.Okada	T.Anzai	I.Fujioka	Refer to Revision Record on page 2.				
Rev.	DATE	DESIGN	CHECK	APPR.	DESCRIPTION	PFU LIMITED		Page	63 / 257
Design	July 27, 2007	K.Okada	CHECK	K.Okada		APPR.	T.Anzai		

4-3-30 “Abnormal command”

Table 4-3-30

Item No.	Check items	How/where to check
1	Does the same symptom occur after turning OFF and ON the scanner?	Press power button of the scanner for more than 2 seconds to turn it OFF, and after more than 2 seconds elapse, press the power button to turn the scanner ON.
2	Replace the Control PCA and see if the error is resolved.	Refer to Section 5-11 for replacement.

4-3-31 “Interface alarm”

Table 4-3-31

Item No.	Check items	How/where to check
1	Does the same symptom occur after turning OFF and ON the scanner?	Press power button of the scanner for more than 2 seconds to turn it OFF, and after more than 2 seconds elapse, press the power button to turn the scanner ON.
2	Replace the Control PCA and see if the error is resolved.	Refer to Section 5-11 for replacement.

4-3-32 Frequent “J1: paper jam” error at Imprinter (with Imprinter installed) fi-6140/fi-6130

(ERG: Document jam 038001 5A)

Table 4-3-32

Item No.	Check items	How/where to check
1	If the EXT cable of the Imprinter connected to the scanner properly?	Refer to step 6 of Section 8-3-2 for the EXT cable.
2	Clean the Imprinter roller and see if the error is resolved.	Cleaning the Imprinter roller: Refer to Section 8-9-3.
3	Check of the sensor lever moves smoothly. If it does not move smoothly, reinstall the sensor correctly.	Refer to Section 8-6-10. Replace the Sensor if damaged.
4	If the Imprinter roller does not rotate, replace the LF Motor.	Refer to Section 8-6-12.
5	Replace the Imprinter Control PCA (IMP CT).	Refer to Section 8-6-9.

4-3-33 Error detection of “U5:Imprinter cover open” (with Imprinter installed) fi-6140/fi-6130

(ERG: ADF cover opened 038002 4A)

Table 4-3-33

Item No.	Check items	How/where to check
1	Does the same symptom occur after turning OFF and ON the scanner?	Press power button of the scanner for more than 2 seconds to turn it OFF, and after more than 2 seconds elapse, press the power button to turn the scanner ON.
2	Is there a slip of paper left near the Imprinter cover open sensor?	Open the Imprinter cover and check inside visually. Refer to Section 6-2 “Saving EEPROM data” for the Imprinter Cover Open sensor installation position.
3	Check if the Switch of the Imprinter performs correctly.	Referring to Section 6-1-2, perform the sensor test and check if the Imprinter Cover open sensor operates properly. Refer to Section 6-2 “Saving EEPROM data” for the Imprinter Cover Open sensor installation position. If the sensor does not operate properly, check if the sensor cable is correctly connected. If the sensor is defective, replace the Switch. (Refer to Section 8-6-11 “Switch (Cover open detection).”)

08	July 27, 09	K.Okada	A.Miyoshi	I.Fujioka	Refer to Revision Record on page 2.	TITLE	fi-6140/fi-6240/fi-6130/fi-6230/fi-614PR Maintenance Manual		
07	Nov.12, 08	K.Okada	T.Anzai	I.Fujioka	Refer to Revision Record on page 2.	DRAW No.	P1PA03540-B0XX/6		CUST.
06	Mar.10, 08	K.Okada	T.Anzai	I.Fujioka	Refer to Revision Record on page 2.				
Rev.	DATE	DESIGN	CHECK	APPR.	DESCRIPTION	PFU LIMITED		Page	64 / 257
Design	July 27, 2007	K.Okada	CHECK	K.Okada		APPR.	T.Anzai		

4-3-34 Imprinter does not initially operate (with Imprinter installed) fi-6140/fi-6130

Table 4-3-34

Item No.	Check items	How/where to check
1	Check if the Imprinter EXT cable is correctly connected to the scanner.	Refer to step 6 in Section 8-3-2 for the EXT cable.
2	Replace the Imprinter Control PCA (IMP CT) and see if the error is resolved.	Refer to Section 8-6-9.
3	Replace the Scanner Control PCA.	Refer to Section 5-11.

4-3-35 "U6: No print cartridge" (with Imprinter installed) fi-6140/fi-6130

Table 4-3-35

Item No.	Check items	How/where to check
1	Check if the Print cartridge is correctly installed.	Refer to Section 8-3-3.
2	Remove the Print cartridge and check if the electrode at the attaching area is dirty.	Clean it if dirty by referring to Section 8-9-1.
3	Replace the Print cartridge and see if the error is resolved.	Refer to Section 8-9-4.
4	The performance between the Print cartridge and Imprinter Control PCA (IMP CT) may be defective. Check the connection of the parts on the right and replace them if necessary.	The parts that may need to be replaced: IM Holder ASSY3 (Section 8-6-8) PR Harness (Section 8-6-13) IMP JNT (Section 8-6-7)
5	Replace the Imprinter Control PCA (IMP CT) and see if the error is resolved.	Refer to Section 8-6-9.

						TITLE	fi-6140/fi-6240/fi-6130/fi-6230/fi-614PR Maintenance Manual		
08	July 27, 09	K.Okada	A.Miyoshi	I.Fujioka	Refer to Revision Record on page 2.	DRAW No.	P1PA03540-B0XX/6	CUST.	
07	Nov.12, 08	K.Okada	T.Anzai	I.Fujioka	Refer to Revision Record on page 2.				
06	Mar.10, 08	K.Okada	T.Anzai	I.Fujioka	Refer to Revision Record on page 2.				
Rev.	DATE	DESIGN	CHECK	APPR.	DESCRIPTION	PFU LIMITED		Page	65 / 257
Design	July 27, 2007	K.Okada	CHECK	K.Okada		APPR.	T.Anzai		

4-3-36 “H6: Imprinter fuse blown” (with Imprinter installed) fi-6140/fi-6130

Table 4-3-36

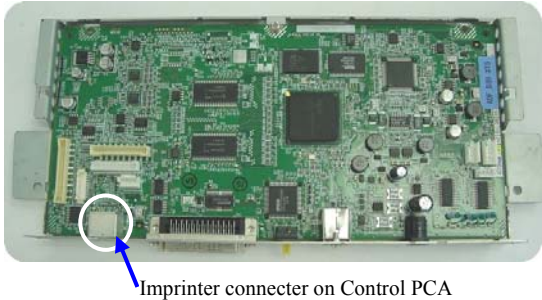
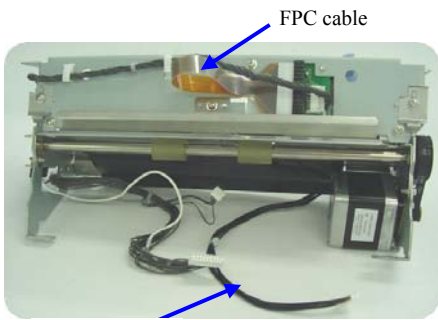
Item No.	Check items	How/where to check
1	Check visibly if there are any foreign objects around Imprinter connector on the Scanner Control PCA.	 <p>Imprinter connector on Control PCA</p>
2	Check visibly if there are any foreign objects on the Imprinter Control PCA (IMP CT)	Refer to Section 8-6-9.
3	Check visibly if there are any problems on the FPC Cable (print head cable) or LF motor cable.	 <p>FPC cable</p> <p>LF motor cable</p>
4	Replace the Imprinter Control PCA (IMP CT) and see if the error is resolved.	Refer to Section 8-6-9.
5	Replace the Scanner Control PCA and see if the error is resolved.	Refer to Section 5-11.

4-3-37 “A0: Imprinter control board alarm” (with Imprinter installed) fi-6140/fi-6130

“A1: Imprinter communication timeout” (with Imprinter installed) fi-6140/fi-6130

“A2: Ink head alarm” (with Imprinter installed) fi-6140/fi-6130

“A3: Imprinter EEPROM alarm” (with Imprinter installed) fi-6140/fi-6130

“A4: Imprinter ROM alarm” (with Imprinter installed) fi-6140/fi-6130

Table 4-3-37

Item No.	Check items	How/where to check
1	Check if the Print cartridge is installed properly.	Refer to Section 8-3-3.
2	Replace the Print cartridge and see if the error is resolved.	Refer to Section 8-9-4.
3	Connect the EXT cable from the Imprinter correctly and see if the error is resolved.	Refer to step 6 in Section 8-3-2 for the EXT cable.
4	Does the same symptom occur after turning OFF and ON the scanner?	Press power button of the scanner for more than 2 seconds to turn it OFF, and after more than 2 seconds elapse, press the power button to turn the scanner ON.
5	Replace the Imprinter Control PCA (IMP CT) and see if the error is resolved.	Refer to Section 8-6-9.
6	Replace the Scanner Control PCA and see if the error is resolved.	Refer to Section 5-11.

						TITLE	fi-6140/fi-6240/fi-6130/fi-6230/fi-614PR Maintenance Manual		
08	July 27, 09	K.Okada	A.Miyoshi	I.Fujioka	Refer to Revision Record on page 2.	DRAW No.	P1PA03540-B0XX/6	Page	66 / 257
07	Nov.12, 08	K.Okada	T.Anzai	I.Fujioka	Refer to Revision Record on page 2.				
06	Mar.10, 08	K.Okada	T.Anzai	I.Fujioka	Refer to Revision Record on page 2.				
Rev.	DATE	DESIGN	CHECK	APPR.	DESCRIPTION	PFU LIMITED			
Design	July 27, 2007	K.Okada	CHECK	K.Okada		APPR.	T.Anzai		

4-3-38 No printing / Printed letters are distorted (with Imprinter installed) fi-6140/fi-6130

Table 4-3-38

Item No.	Check items	How/where to check
1	Check if the screen on the Section 8-9-4 is displayed.	If the screen appears, replace the print cartridge (Refer to Section 8-9-4).
2	Turn ON/OFF the power several times and perform printing. Does the same symptom occur? (Be sure that the scanner becomes "Ready" before turning it OFF.)	
3	Clean the nozzle of the Print cartridge and see if the error is resolved.	Refer to Section 8-9-1.
4	The performance between the Print cartridge and Imprinter Control PCA (IMP CT) may be defective. Check the connection of the parts on the right and replace them if necessary.	The parts that may need to be replaced: IM Holder ASSY3 (Section 8-6-8) PR Harness (Section 8-6-13) IMP JNT (Section 8-6-7)

4-3-39 Print form is dirty (with Imprinter installed) fi-6140/fi-6130

Table 4-3-39

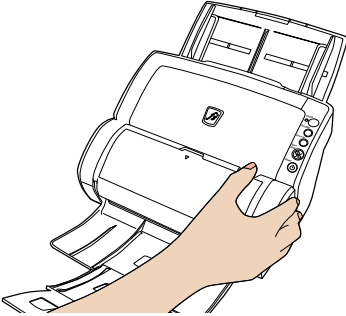
Item No.	Check items	How/where to check
1	Is the Imprinter unit dirty by ink? Open the printing section to check it. 	Refer to the following sections to clean up. Sections 8-9-1, 8-9-2, 8-9-3
2	Replace the IM Felt.	Refer to Section 8-6-14.

4-3-40 Printing is interrupted in process (with Imprinter installed) fi-6140/fi-6130

Table 4-3-40

Item No.	Check items	How/where to check
1	Check if the printing position is specified within the printable area. (Refer to Section 8-1-1 for Printing area, and Section 8-8-3 for print setting.) Is the appropriate size (length) of paper used?	Check if the printing section or length is out of the printing area.
2	The performance between the Print cartridge and Imprinter Control PCA (IMP CT) may be defective. Check the connection of the parts on the right and replace them if necessary.	The parts that may need to be replaced: IM Holder ASSY3 (Section 8-6-8) PR Harness (Section 8-6-13) IMP JNT (Section 8-6-9)
3	Replace the Imprinter Control PCA (IMP CT) and see if the error is resolved.	Refer to Section 8-6-9.

08	July 27, 09	K.Okada	A.Miyoshi	I.Fujioka	Refer to Revision Record on page 2.	TITLE	fi-6140/fi-6240/fi-6130/fi-6230/fi-614PR Maintenance Manual		
07	Nov.12, 08	K.Okada	T.Anzai	I.Fujioka	Refer to Revision Record on page 2.	DRAW No.	P1PA03540-B0XX/6		CUST.
06	Mar.10, 08	K.Okada	T.Anzai	I.Fujioka	Refer to Revision Record on page 2.				
Rev.	DATE	DESIGN	CHECK	APPR.	DESCRIPTION	PFU LIMITED		Page	67 / 257
Design	July 27, 2007	K.Okada	CHECK	K.Okada		APPR.	T.Anzai		

4-3-41 Frequent “J0: paper jam” (paper protection function) fi-6140/fi-6240

Paper protection function:

Detects folded documents or nonconforming thin paper, and cancels scanning.

Table 4-3-41

Item No.	Check items	How/where to check
1	Does the document satisfy the paper specification?	Refer to Section 1-1-6.
2	Have the documents been jogged?	<ul style="list-style-type: none"> • Align the edge of documents for stable paper feeding. • Remove documents with crease or dog-ear. • Scanning different width of documents may cause skew and result in paper jam.
3	Are Chuter Unit (ADF paper chute), Guide P ASSY (Sheet guide), Feed roller cover (plate guide) and Brake roller cover installed correctly?	Chuter Unit (ADF paper chute): Refer to Section 5-8-1 Guide P ASSY (Sheet guide): Refer to Section 5-9-8. Feed roller cover (plate guide): Refer to Section 5-10-7. Brake roller cover: Refer to Section 7-3-3.
4	Replace Pick roller or Brake roller, and see if the error is resolved.	Check the consumable counter from the TWAIN driver screen or from the built-in Maintenance mode. When the counter exceeds the values shown in Section 7-3-1, replace Pick roller or Brake roller.
5	Check the performance of PICK sensor or TOP sensor. If not operating, then replace the sensor.	Referring to Section 6-1-2, perform the sensor test. Refer to Section 6-2 “Saving EEPROM data” for the sensor installation position. PICK sensor/TOP sensor: Refer to Section 5-9-5.
6	Check the performance of the Cover Open Sensor. If not operating, then replace the sensor.	Referring to Section 6-1-2, perform the sensor test. Refer to Section 6-2 “Saving EEPROM data” for the sensor installation position. Cover open sensor: Refer to Section 5-9-12.
7	Check if the Paper protection roller rotates and moves up and down smoothly. If not operating, then replace the Base Unit.	Refer to Section 6-2 “Saving EEPROM data” for the installation position of the Paper protection roller. Base Unit: Refer to Section 5-9-1.
8	Replace the Control PCA and see if the error is resolved.	Refer to Section 5-11.

						TITLE	fi-6140/fi-6240/fi-6130/fi-6230/fi-614PR Maintenance Manual		
08	July 27, 09	K.Okada	A.Miyoshi	I.Fujioka	Refer to Revision Record on page 2.	DRAW	P1PA03540-B0XX/6	CUST.	
07	Nov.12, 08	K.Okada	T.Anzai	I.Fujioka	Refer to Revision Record on page 2.	No.			
06	Mar.10, 08	K.Okada	T.Anzai	I.Fujioka	Refer to Revision Record on page 2.				
Rev.	DATE	DESIGN	CHECK	APPR.	DESCRIPTION	PFU LIMITED		Page	68 / 257
Design	July 27, 2007	K.Okada	CHECK	K.Okada		APPR.	T.Anzai		

Chapter 5 Disassembly/Assembly

This chapter describes how to replace the maintenance parts, and clean the scanner to ensure the normal operations. When assembling the maintenance parts, conduct necessary cleaning when instructed in this manual.

5-1 For the safety operation

Please read this page carefully before disassembling or assembling.



Warning

Electric shock

Before disassembling and assembling, turn the power switch off, and unplug the AC power source from the outlet. If you do not do this, an electric shock may occur.



CAUTION

Injury

Be careful not to get your fingers, hair, clothes or accessories caught in a moving part. It may cause injury.

Machine damage

Static Electricity may cause the damage to the scanner.
When repairing the scanner, wear a wrist strap to avoid ESD.

Notes when cleaning

When cleaning the scanner, be careful not to allow foreign matter, such as dried ink and toner, to fall inside the scanner.

How to unlock Plastic hooks

Many parts of the scanner are held in place with plastic hooks.
When removing parts that are held in place with hooks, be very careful not to break the hooks.
Pull out the latch to unlock, then pull up on the assembly to remove.

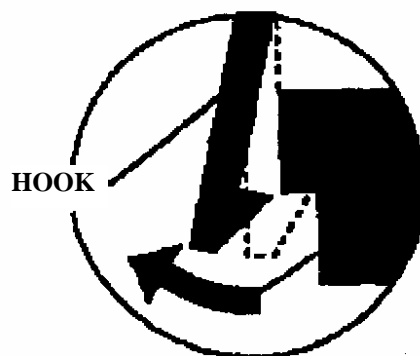

Do not use excessive force when removing parts held in place with hooks.

						TITLE	fi-6140/fi-6240/fi-6130/fi-6230/fi-614PR Maintenance Manual		
08	July 27, 09	K.Okada	A.Miyoshi	I.Fujioka	Refer to Revision Record on page 2.	DRAW	P1PA03540-B0XX/6	CUST.	
07	Nov.12, 08	K.Okada	T.Anzai	I.Fujioka	Refer to Revision Record on page 2.	No.			
06	Mar.10, 08	K.Okada	T.Anzai	I.Fujioka	Refer to Revision Record on page 2.				
Rev.	DATE	DESIGN	CHECK	APPR.	DESCRIPTION	PFU LIMITED		Page	69 / 257
Design	July 27, 2007	K.Okada	CHECK	K.Okada		APPR.	T.Anzai		

5-2 Periodic Maintenance

This scanner is recommended to have periodic maintenance according to the following cycle.

Item	Maintenance cycle
Periodic maintenance	Every 12 months

At maintenance, check the following parts and clean if dirty.

- OPT Unit (Common to ADF front side, ADF backside, and Flatbed) (Refer to Section 5-3-1)
- Glass inside of Base Unit (Refer to Section 5-3-2)
- Glass inside of Upper Unit (Refer to Section 5-3-3)
- Glass inside of Flatbed (Refer to Section 5-3-4) fi-6240/fi-6230
- White reference sheet inside of Base Unit (Refer to Section 5-3-5)
- White reference sheet inside of Upper Unit (Refer to Section 5-3-6)

						TITLE	fi-6140/fi-6240/fi-6130/fi-6230/fi-614PR Maintenance Manual		
08	July 27, 09	K.Okada	A.Miyoshi	I.Fujioka	Refer to Revision Record on page 2.	DRAW No.	P1PA03540-B0XX/6	CUST.	
07	Nov.12, 08	K.Okada	T.Anzai	I.Fujioka	Refer to Revision Record on page 2.				
06	Mar.10, 08	K.Okada	T.Anzai	I.Fujioka	Refer to Revision Record on page 2.				
Rev.	DATE	DESIGN	CHECK	APPR.	DESCRIPTION	PFU LIMITED		Page	70 / 257
Design	July 27, 2007	K.Okada	CHECK	K.Okada		APPR.	T.Anzai		

5-3 Cleaning

5-3-1 OPT Unit (common to ADF front/backside and Flatbed)

Follow the procedure below to clean the OPT Unit.

- 1) Referring to disassembly/assembly procedure of the OPT Unit, remove the OPT Unit (of ADF front/backside, FB).
- 2) Clean the mirrors (especially the first mirror shown below) inside of the OPT Unit with a blower brush only. Do NOT apply external force by wiping with a cloth directly.
- 3) After cleaning, install the OPT Unit in the reverse order of removal.

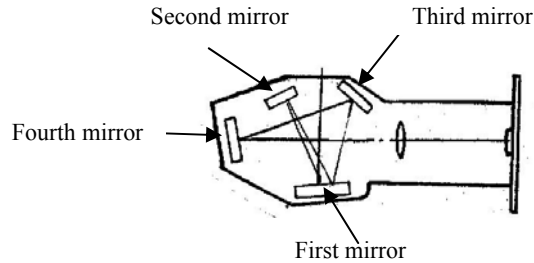

NOTICE

1. Wiping the mirror with cleaning liquid such as alcohol may leave the residues on the mirrors.
2. Reflecting sides of the mirrors (aluminum vapor deposition part) face inside of the OPT Unit.
3. Conduct the procedure under dust-free environment.
4. Do NOT apply external force to the OPT frame, Mirror, Mirror holder and CCD board.

5-3-2 Glass inside of Base Unit

Follow the procedure below to clean the glass inside of the Base Unit.

- 4) Referring to Section 5-9-4 "Lamp (for front side scanning)," remove the Lamp.
- 5) Clean inside of the glass of Base Unit with a cloth moistened with alcohol. Be sure that no fabric from the cloth remains on the glass surface and that the glass is cleaned evenly.
- 6) After cleaning, install the Lamp in the reverse order of removal.

NOTICE

1. Take care not to damage the Lamp as it is thin.
2. Conduct the procedure under dust-free environment.
3. Do NOT apply external force to the OPT frame, Mirror, Mirror holder and CCD board.

5-3-3 Glass inside of Upper Unit

Follow the procedure below to clean the glass inside of the Upper Unit.

- 1) Referring to Section 5-10-6 "Lamp (for backside scanning)," remove the Lamp.
- 2) Clean inside of the glass of the Upper Unit with a cloth moistened with alcohol. Be sure that no fabric from the cloth remains on the glass surface and that the glass is cleaned evenly.
- 3) After cleaning, install the Lamp in the reverse order of removal.

NOTICE

1. Take care not to damage the Lamp as it is thin.
2. Conduct the procedure under dust-free environment.
3. Do NOT apply external force to the OPT frame, Mirror, Mirror holder and CCD board.

						TITLE	fi-6140/fi-6240/fi-6130/fi-6230/fi-614PR Maintenance Manual		
08	July 27, 09	K.Okada	A.Miyoshi	I.Fujioka	Refer to Revision Record on page 2.	DRAW	No.	P1PA03540-B0XX/6	CUST.
07	Nov.12, 08	K.Okada	T.Anzai	I.Fujioka	Refer to Revision Record on page 2.				
06	Mar.10, 08	K.Okada	T.Anzai	I.Fujioka	Refer to Revision Record on page 2.				
Rev.	DATE	DESIGN	CHECK	APPR.	DESCRIPTION	PFU LIMITED		Page	71 / 257
Design	July 27, 2007	K.Okada	CHECK	K.Okada		APPR.	T.Anzai		

5-3-4 Glass inside of Flatbed fi-6240/fi-6230

Follow the procedure below to clean the glass inside of the Flatbed. 07

~~1) Referring to Section 5-12-7 “Lamp (fi-6240/fi-6230),” remove the Lamp.~~

- 1) Referring to Section 5-12-1, remove the FB Top cover.
- 2) Clean inside of the glass of the OPT BOX Unit FB Top Cover with a cloth moistened with alcohol. Be sure that no fabric from the cloth remains on the glass surface and that the glass is cleaned evenly.
- 3) After cleaning, install the Lamp in the reverse order of removal.

 **NOTICE**

1. Take care not to damage the Lamp as it is thin.
2. Conduct the procedure under dust-free environment.
3. Do NOT apply external force to the OPT frame, Mirror, Mirror holder and CCD board.

5-3-5 White reference inside of Base Unit

Follow the procedure below to clean the white reference inside of the Base Unit.

- 1) Referring to Section 5-9-4 “Lamp (fro front side scanning),” remove the Lamp.
- 2) Rotate the white reference sheet of the Base Unit 90 degrees, and clean it with a cloth moistened with alcohol or a blower brush. Be sure that no fabric from the cloth remains on the white reference sheet and that white reference sheet is cleaned evenly.
- 3) After cleaning, install the Lamp in the reverse order of removal.

 **NOTICE**

1. Take care not to damage the Lamp as it is thin.
2. Conduct the procedure under dust-free environment.
3. Do NOT apply external force to the OPT frame, Mirror, Mirror holder and CCD board.

5-3-6 White reference inside of Upper Unit

Follow the procedure below to clean the white reference inside of the Upper Unit.

- 1) Referring to Section 5-10-6 “Lamp (for backside scanning),” remove the Lamp.
- 2) Rotate the white reference sheet of the Upper Unit 90 degrees, and clean it with a cloth moistened with alcohol or a blower brush. Be sure that no fabric from the cloth remains on the white reference sheet and that white reference sheet is cleaned evenly.
- 3) After cleaning, install the Lamp in the reverse order of removal.

 **NOTICE**

1. Take care not to damage the Lamp as it is thin.
2. Conduct the procedure under dust-free environment.
3. Do NOT apply external force to the OPT frame, Mirror, Mirror holder and CCD board.

						TITLE	fi-6140/fi-6240/fi-6130/fi-6230/fi-614PR Maintenance Manual		
08	July 27, 09	K.Okada	A.Miyoshi	I.Fujioka	Refer to Revision Record on page 2.	DRAW No.	P1PA03540-B0XX/6	CUST.	
07	Nov.12, 08	K.Okada	T.Anzai	I.Fujioka	Refer to Revision Record on page 2.				
06	Mar.10, 08	K.Okada	T.Anzai	I.Fujioka	Refer to Revision Record on page 2.				
Rev.	DATE	DESIGN	CHECK	APPR.	DESCRIPTION	PFU LIMITED		Page	72 / 257
Design	July 27, 2007	K.Okada	CHECK	K.Okada		APPR.	T.Anzai		

5-4 Maintenance tool

Special tools to clean this scanner are shown in table 4-4.

Table 4-4

No.	Tools	When to use	Remarks
1	Philips screwdriver	Screwing in general	For M3, M4 screws
2	Small Philips screwdriver	Removing Control PCA I/F and BW Motor	For M2.5 screws
3	Spring balance	Adjusting belt tension	1 kg force
4	Alcohol	Cleaning	Ethyl alcohol
5	Blower brush	Cleaning mirrors, removing dust	
	Grove or cloth	Handling CR shaft	
6	Small flat-blade screwdriver	Removing sensors and connectors	
7	White level adjustment sheet	White level adjustment (Section 6-1-5)	Part number: PA03277-Y123 Purchase this sheet prior to maintenance.
8	Magnification/Offset adjustment sheet	Magnification/Offset adjustment (Sections 6-1-3, 6-1-4)	Prepare the sheet described in Figure 6-1-3 (Section 6-1-3 "Maintenance Mode #2") in advance.

Rev.	DATE	DESIGN	CHECK	APPR.	DESCRIPTION	TITLE	DRAW No.		CUST.
08	July 27, 09	K.Okada	A.Miyoshi	I.Fujioka	Refer to Revision Record on page 2.	fi-6140/fi-6240/fi-6130/fi-6230/fi-614PR Maintenance Manual	P1PA03540-B0XX/6		
07	Nov.12, 08	K.Okada	T.Anzai	I.Fujioka	Refer to Revision Record on page 2.				
06	Mar.10, 08	K.Okada	T.Anzai	I.Fujioka	Refer to Revision Record on page 2.				
Design	July 27, 2007	K.Okada	CHECK	K.Okada		PFU LIMITED	Page	73 / 257	

5-5 Parts that should not be Disassembled

NOTICE

- The following screws are adjusted and secured at shipment from factory. Do not attempt to disassemble nor loose them.
- Refer to Appendix for the specification of the screws.

(1) **OPT Unit**

Do not disassemble any screws and any parts (including printed board and mirrors) of the OPT Unit.

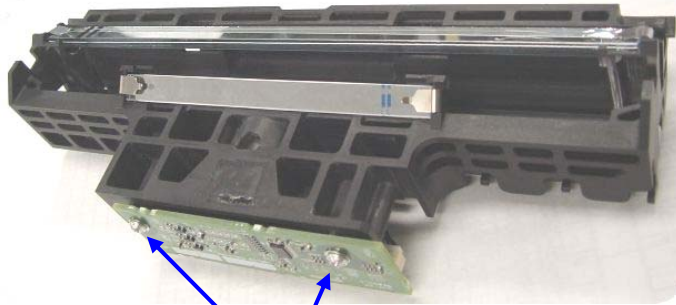

CCD board fixing screws A

(2) **CR Belt tension bracket fixing screw** fi-6240/fi-6230

If you have accidentally loosened this screw, adjust the belt tension referring to <Installation> of Section 5-12-2 “FB Motor Unit.”

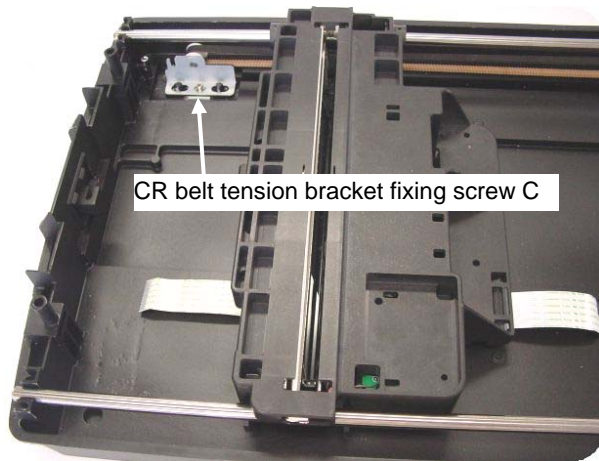

CR belt tension bracket fixing screw C

(3) **FB Motor fixing screws** fi-6240/fi-6230

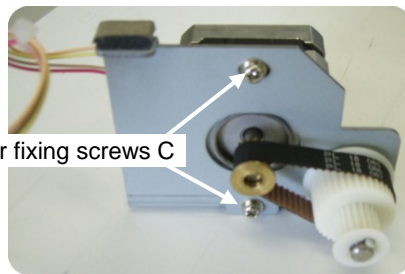

FB motor fixing screws C

5-6 (Reserved)

						TITLE	fi-6140/fi-6240/fi-6130/fi-6230/fi-614PR Maintenance Manual		
08	July 27, 09	K.Okada	A.Miyoshi	I.Fujioka	Refer to Revision Record on page 2.	DRAW No.	P1PA03540-B0XX/6	CUST.	
07	Nov.12, 08	K.Okada	T.Anzai	I.Fujioka	Refer to Revision Record on page 2.				
06	Mar.10, 08	K.Okada	T.Anzai	I.Fujioka	Refer to Revision Record on page 2.				
Rev.	DATE	DESIGN	CHECK	APPR.	DESCRIPTION	PFU LIMITED		Page	74 / 257
Design	July 27, 2007	K.Okada	CHECK	K.Okada					

5-7 Removing Flatbed **fi-6240/fi-6230**

NOTICE

- Refer to Appendix for the specification of the screws.

<Removal>

1. Remove Flatbed.

- (1) - Place the scanner at the edge of a table as shown in the lower right photo.
 - Remove two screws C (circles below) at the bottom of the Flatbed.

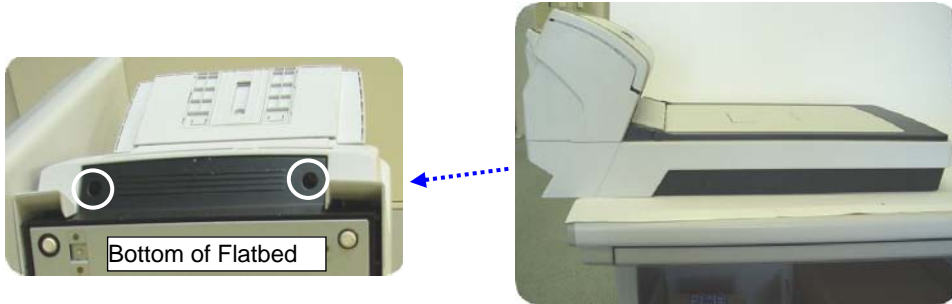

- (2) Move the ADF section toward rear of the scanner **1**. Rotating the ADF section **2**, place it on the Flatbed section **3**.

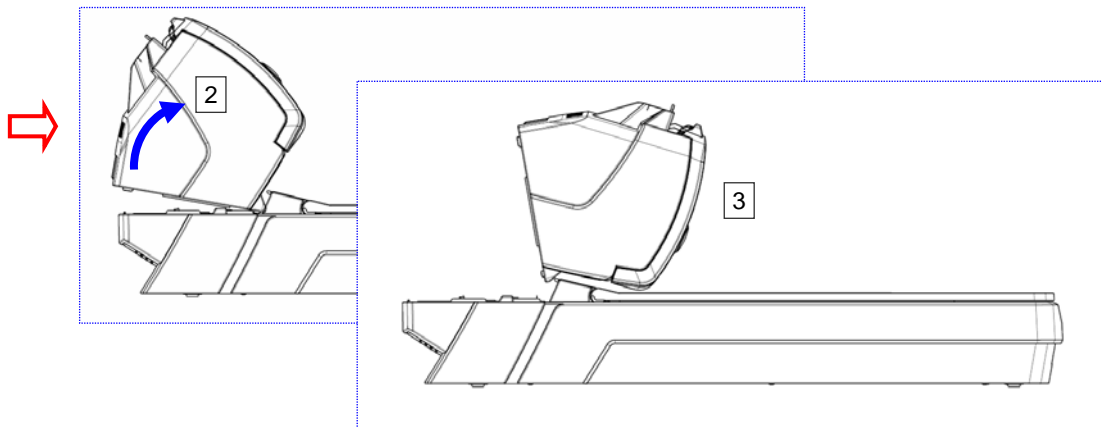
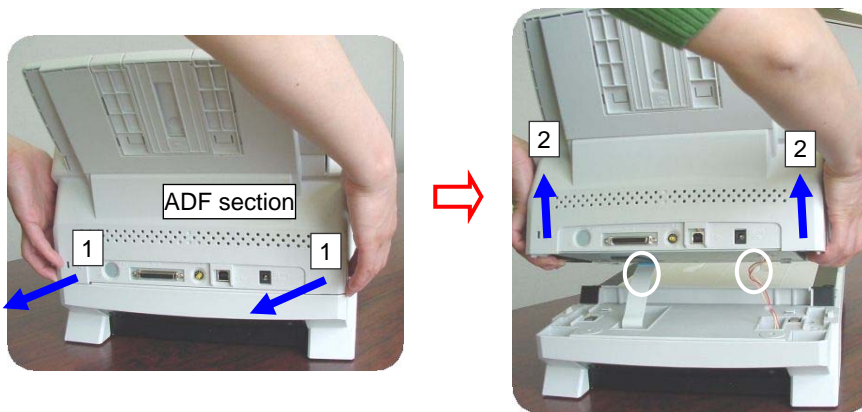

						TITLE	fi-6140/fi-6240/fi-6130/fi-6230/fi-614PR Maintenance Manual		
08	July 27, 09	K.Okada	A.Miyoshi	I.Fujioka	Refer to Revision Record on page 2.	DRAW	P1PA03540-B0XX/6	CUST.	
07	Nov.12, 08	K.Okada	T.Anzai	I.Fujioka	Refer to Revision Record on page 2.	No.			
06	Mar.10, 08	K.Okada	T.Anzai	I.Fujioka	Refer to Revision Record on page 2.				
Rev.	DATE	DESIGN	CHECK	APPR.	DESCRIPTION	PFU LIMITED		Page	75 / 257
Design	July 27, 2007	K.Okada	CHECK	K.Okada		APPR.	T.Anzai		

(3) Disconnect the CR Cable and the FB Motor Cable (circles below).

Note: Unlock the connector of the CR Cable.

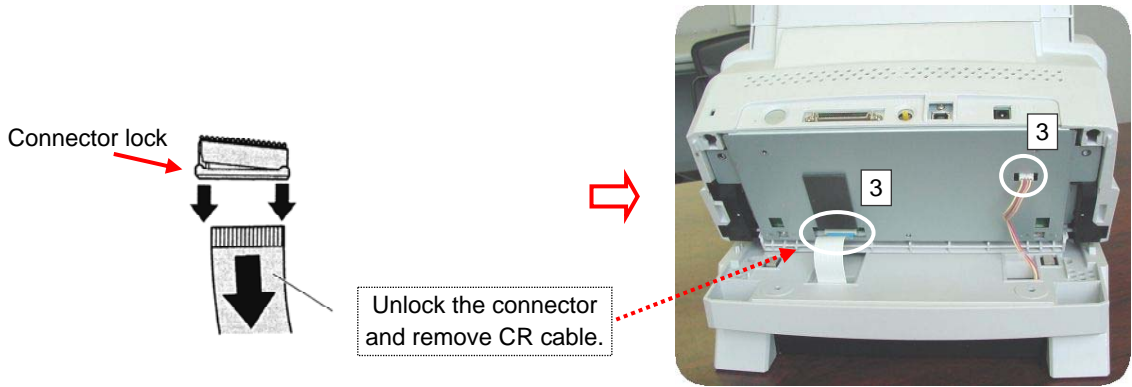

<Installation>

Follow the above procedure in reverse.

Note: Bury the CR cable and FB Motor cable in the hole. Do NOT pinch these cables between ADF and Flatbed sections.

Note: Make sure that there is no gap between the ADF and Flatbed sections.

						TITLE	fi-6140/fi-6240/fi-6130/fi-6230/fi-614PR Maintenance Manual		
08	July 27, 09	K.Okada	A.Miyoshi	I.Fujioka	Refer to Revision Record on page 2.	DRAW	P1PA03540-B0XX/6	CUST.	
07	Nov.12, 08	K.Okada	T.Anzai	I.Fujioka	Refer to Revision Record on page 2.	No.			
06	Mar.10, 08	K.Okada	T.Anzai	I.Fujioka	Refer to Revision Record on page 2.				
Rev.	DATE	DESIGN	CHECK	APPR.	DESCRIPTION	PFU LIMITED		Page	76 / 257
Design	July 27, 2007	K.Okada	CHECK	K.Okada		APPR.	T.Anzai		

5-8 Chuter Unit (ADF Paper Chute), Stacker Unit

5-8-1 Chuter Unit (ADF Paper Chute)

NOTICE

Refer to Section 3-17 for the part number of the replacement part.

<Removal>

1. Remove Chuter Unit (ADF paper chute)

- (1) - Raise the Chuter Unit (ADF paper chute) toward the front side of the scanner. 1
- Lift up the Chuter Unit (ADF paper chute) 2 to remove.

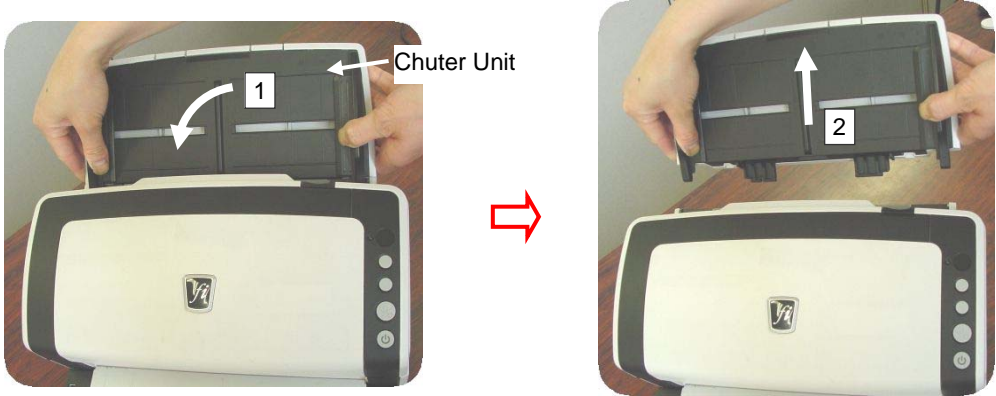

<Installation>

Follow the above procedure in reverse.

Hold the Chuter Unit (ADF paper chute) and insert its tabs into the corresponding slots in the scanner as shown below. The side guides of the Chuter Unit (ADF paper chute) have to face up.

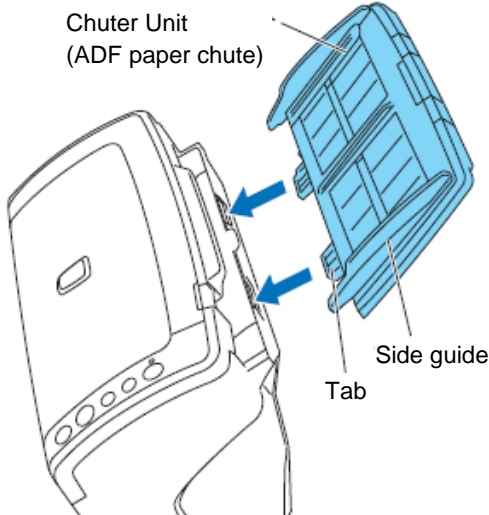

						TITLE	fi-6140/fi-6240/fi-6130/fi-6230/fi-614PR Maintenance Manual		
08	July 27, 09	K.Okada	A.Miyoshi	I.Fujioka	Refer to Revision Record on page 2.	DRAW	P1PA03540-B0XX/6	CUST.	
07	Nov.12, 08	K.Okada	T.Anzai	I.Fujioka	Refer to Revision Record on page 2.	No.			
06	Mar.10, 08	K.Okada	T.Anzai	I.Fujioka	Refer to Revision Record on page 2.				
Rev.	DATE	DESIGN	CHECK	APPR.	DESCRIPTION	PFU LIMITED		Page	77 / 257
Design	July 27, 2007	K.Okada	CHECK	K.Okada		APPR.	T.Anzai		

5-8-2 Stacker Unit **fi-6140/fi-6130**

NOTICE

Refer to Section 3-13 for the part number of the replacement part.

<Removal>

1. Remove Stacker Unit.

(1) Bending the center (square below) of the Stacker Unit slightly, remove one pin (circle below) of the Stacker Unit and another, and then remove the Stacker Unit.

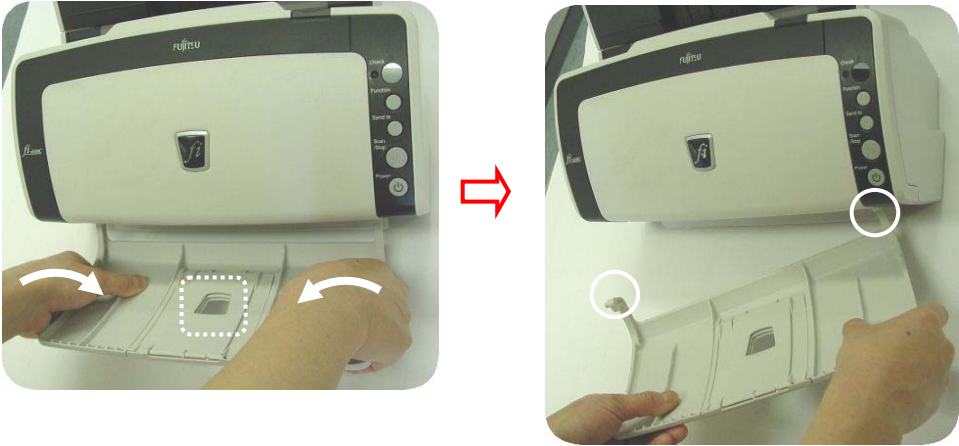

<Installation>

Follow the above procedure in reverse.

						TITLE	fi-6140/fi-6240/fi-6130/fi-6230/fi-614PR Maintenance Manual		
08	July 27, 09	K.Okada	A.Miyoshi	I.Fujioka	Refer to Revision Record on page 2.	DRAW No.	P1PA03540-B0XX/6	CUST.	
07	Nov.12, 08	K.Okada	T.Anzai	I.Fujioka	Refer to Revision Record on page 2.				
06	Mar.10, 08	K.Okada	T.Anzai	I.Fujioka	Refer to Revision Record on page 2.				
Rev.	DATE	DESIGN	CHECK	APPR.	DESCRIPTION	PFU LIMITED		Page	78 / 257
Design	July 27, 2007	K.Okada	CHECK	K.Okada		APPR.	T.Anzai		

5-9 Base Unit

5-9-1 Base Unit

NOTICE

- Do not touch the glass at the scanning area to prevent contamination at disassembling.
- Refer to Section 3-1 for the part number of the replacement part.
- Refer to Appendix for the specification of the screws.

<Removal>

Remove the imprinter (option).

fi-6140/fi-6130 with Imprinter Referring to Section 8-6-4 “Removing Imprinter”, remove the Imprinter.

Remove Flatbed.

fi-6240/fi-6230 Referring to Section 5-7 “Removing Flatbed”, remove the Flatbed.

1. Remove Chuter Unit.

(1) Referring to Section 5-8-1 “Chuter Unit (ADF Paper Chute)”, remove the Chuter Unit.

2. Remove Control PCA.

(2) Referring to step (2) of Section 5-11 “Control PCA”, remove the Control PCA.

3. Remove Base Unit.

(3) Move two Base Unit cover LIDs at the bottom of the ADF toward the front to remove.

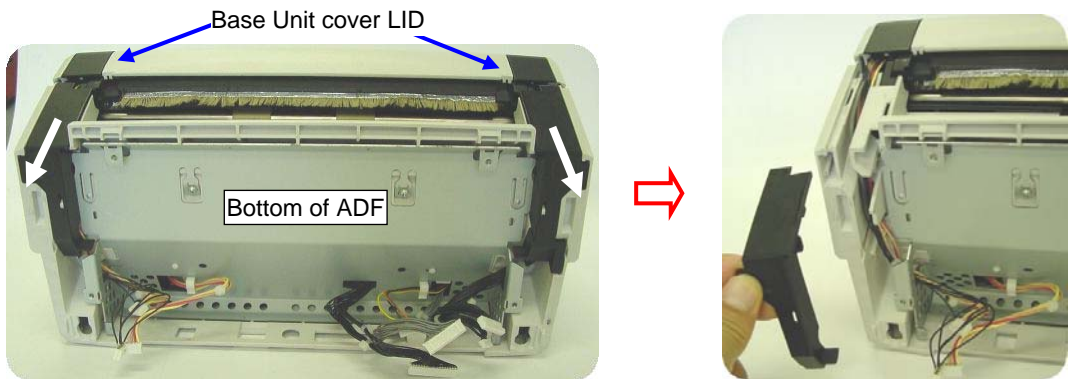

(4) Remove two screws C with washer (squares below) and four TP screws A (circles below) on the Base Unit Cover. **02**

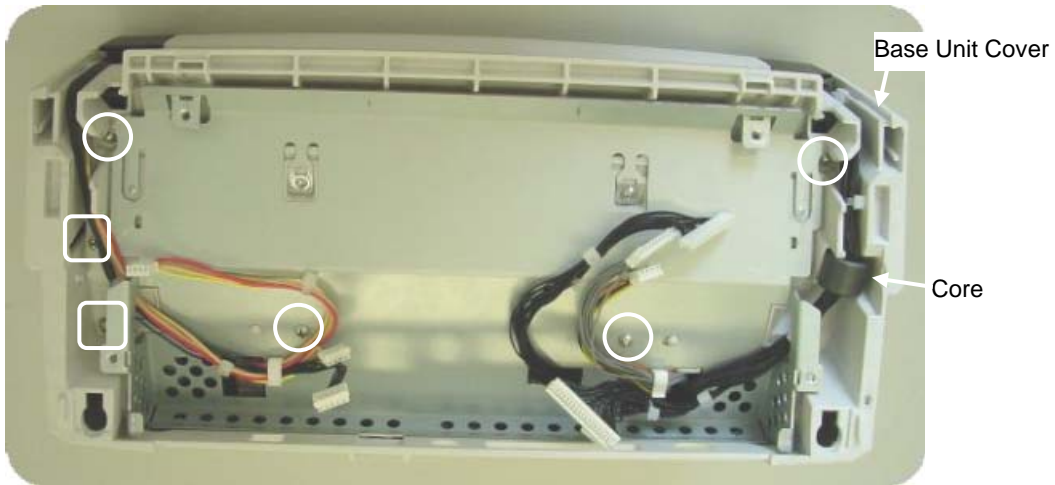

						TITLE	fi-6140/fi-6240/fi-6130/fi-6230/fi-614PR Maintenance Manual		
08	July 27, 09	K.Okada	A.Miyoshi	I.Fujioka	Refer to Revision Record on page 2.	DRAW No.	P1PA03540-B0XX/6	CUST.	
07	Nov.12, 08	K.Okada	T.Anzai	I.Fujioka	Refer to Revision Record on page 2.				
06	Mar.10, 08	K.Okada	T.Anzai	I.Fujioka	Refer to Revision Record on page 2.				
Rev.	DATE	DESIGN	CHECK	APPR.	DESCRIPTION	PFU LIMITED		Page	79 / 257
Design	July 27, 2007	K.Okada	CHECK	K.Okada		APPR.	T.Anzai		

- (5) - Open the Upper Unit.
- Push two claws (circles below) with a flat-blade screwdriver outward to unlatch.

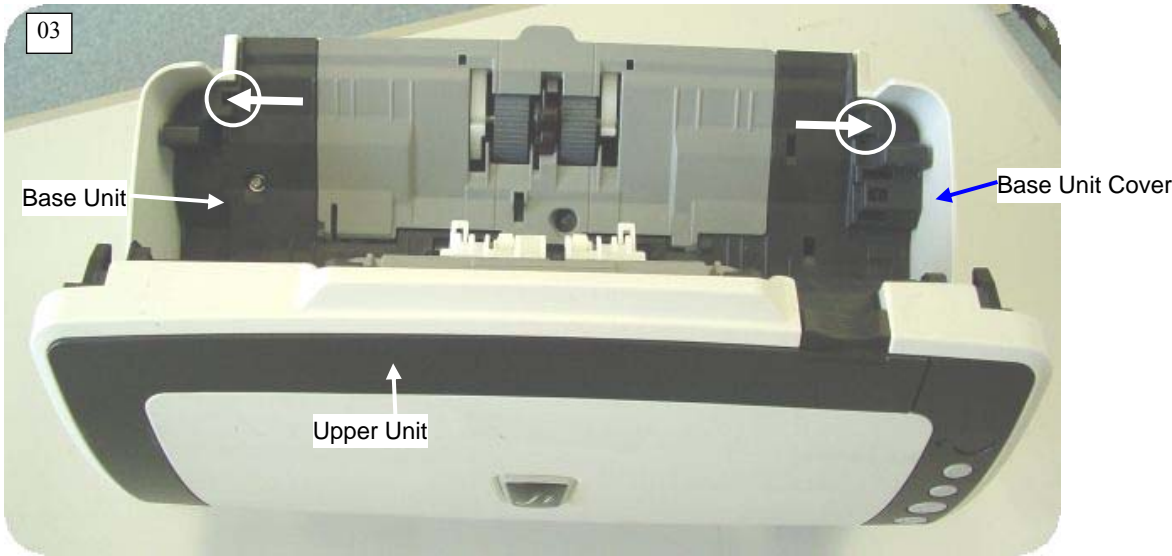

						TITLE	fi-6140/fi-6240/fi-6130/fi-6230/fi-614PR Maintenance Manual		
08	July 27, 09	K.Okada	A.Miyoshi	I.Fujioka	Refer to Revision Record on page 2.	DRAW No.	P1PA03540-B0XX/6	CUST.	
07	Nov.12, 08	K.Okada	T.Anzai	I.Fujioka	Refer to Revision Record on page 2.				
06	Mar.10, 08	K.Okada	T.Anzai	I.Fujioka	Refer to Revision Record on page 2.				
Rev.	DATE	DESIGN	CHECK	APPR.	DESCRIPTION	PFU LIMITED		Page	80 / 257
Design	July 27, 2007	K.Okada	CHECK	K.Okada		APPR.	T.Anzai		

(6) Turn the scanner over, draw up the Base Unit Cover, and then pull eight connectors out of the holes of the Base Unit Cover.

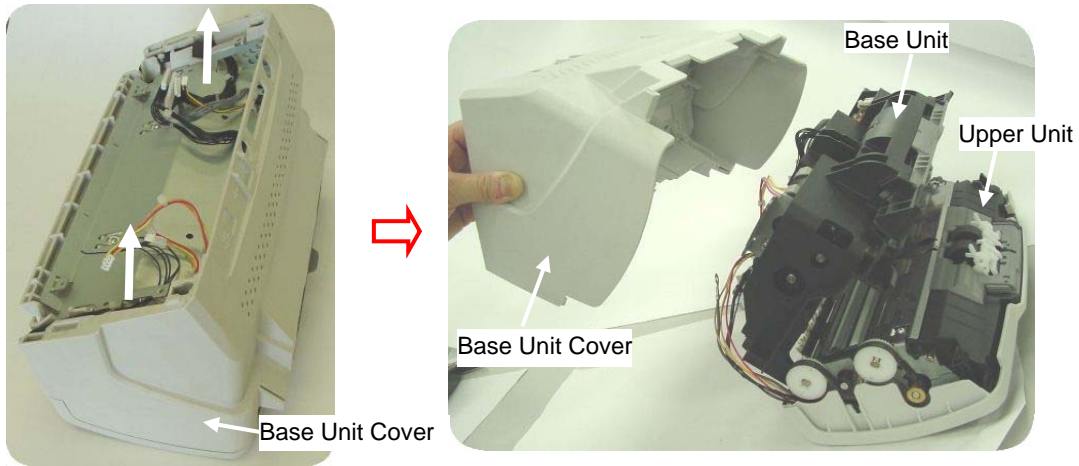

(7) - Open the Upper Unit.

- Insert a flat-blade screwdriver into the gap (circle below) of the fulcrum pin at the Operator panel side on the Upper Unit.
- Tilt the flat-blade screwdriver inward to unlatch the fulcrum pin, and then separate the Upper Unit and Base Unit.

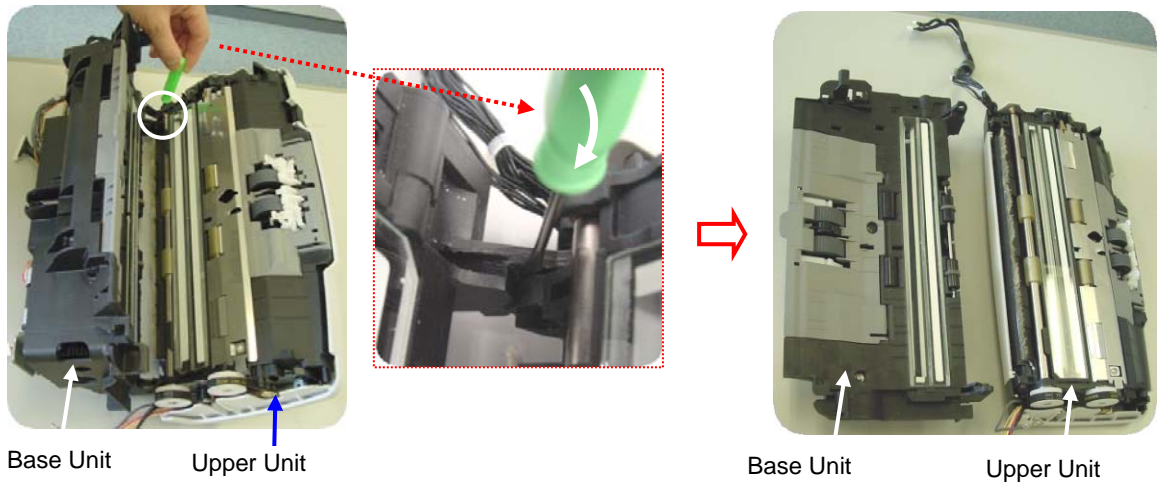

						TITLE	fi-6140/fi-6240/fi-6130/fi-6230/fi-614PR Maintenance Manual		
08	July 27, 09	K.Okada	A.Miyoshi	I.Fujioka	Refer to Revision Record on page 2.	DRAW	P1PA03540-B0XX/6	CUST.	
07	Nov.12, 08	K.Okada	T.Anzai	I.Fujioka	Refer to Revision Record on page 2.	No.			
06	Mar.10, 08	K.Okada	T.Anzai	I.Fujioka	Refer to Revision Record on page 2.				
Rev.	DATE	DESIGN	CHECK	APPR.	DESCRIPTION	PFU LIMITED		Page	81 / 257
Design	July 27, 2007	K.Okada	CHECK	K.Okada		APPR.	T.Anzai		

<Installation>

Follow the above procedure in reverse.

Wire the BS HARNES, SE HARNESS and ADF MOTOR HARNESS from the shield plate holes (circles below).

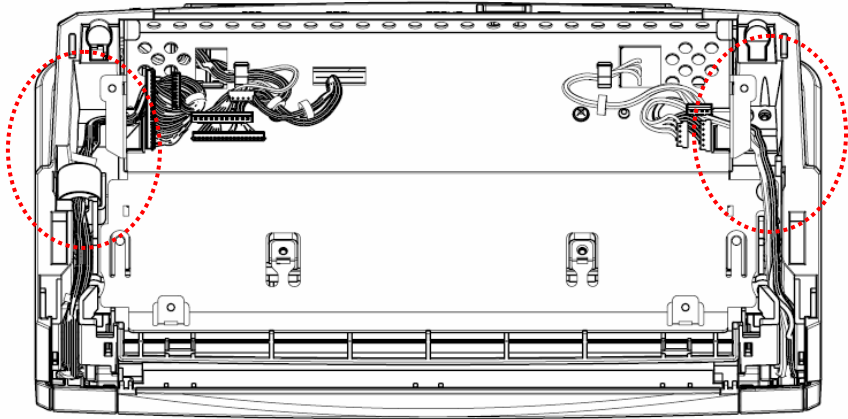

Be careful not to tuck down the cable when installing the Base unit Cover LID.

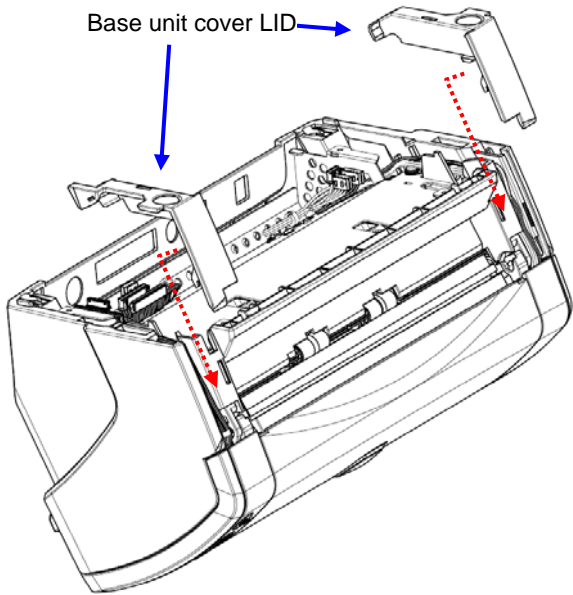

						TITLE	fi-6140/fi-6240/fi-6130/fi-6230/fi-614PR Maintenance Manual		
08	July 27, 09	K.Okada	A.Miyoshi	I.Fujioka	Refer to Revision Record on page 2.	DRAW	P1PA03540-B0XX/6	CUST.	
07	Nov.12, 08	K.Okada	T.Anzai	I.Fujioka	Refer to Revision Record on page 2.	No.			
06	Mar.10, 08	K.Okada	T.Anzai	I.Fujioka	Refer to Revision Record on page 2.				
Rev.	DATE	DESIGN	CHECK	APPR.	DESCRIPTION	PFU LIMITED		Page	82 / 257
Design	July 27, 2007	K.Okada	CHECK	K.Okada		APPR.	T.Anzai		

Note: Do not be confused with the screws C with washer and the TP screws A.

Note: Base Unit includes Pick roller. Referring to Section 7-3-4 "Pick roller replacement," reset the Pick roller counter.

Note: Perform the following adjustments after replacing the parts.

- Referring to Section 6-1-3 "Maintenance Mode #2," adjust the magnification.
- Referring to Section 6-1-4 "Maintenance Mode #3," adjust the offset.
- Referring to Section 6-1-5 "Maintenance Mode #4," adjust the white level.

Note: Clean the glass surface after replacing the part.

						TITLE	fi-6140/fi-6240/fi-6130/fi-6230/fi-614PR Maintenance Manual		
08	July 27, 09	K.Okada	A.Miyoshi	I.Fujioka	Refer to Revision Record on page 2.	DRAW No.	P1PA03540-B0XX/6	CUST.	
07	Nov.12, 08	K.Okada	T.Anzai	I.Fujioka	Refer to Revision Record on page 2.				
06	Mar.10, 08	K.Okada	T.Anzai	I.Fujioka	Refer to Revision Record on page 2.				
Rev.	DATE	DESIGN	CHECK	APPR.	DESCRIPTION	PFU LIMITED		Page	83 / 257
Design	July 27, 2007	K.Okada	CHECK	K.Okada		APPR.	T.Anzai		

5-9-2 Base ASSY

 NOTICE

- The OPT Unit is not included.
- Remove the OPT Unit from the Base Unit. The remaining assembly is Base ASSY.
- Re-install the OPT Unit.
- Refer to Section 3-2 for the part number of the replacement part.

<Removal>

Remove the imprinter (option)

fi-6140/fi-6130 with Imprinter Referring to Section 8-6-4 "Removing Imprinter", remove the Imprinter.

Remove Flatbed.

fi-6240/fi-6230 Referring to Section 5-7 "Removing Flatbed," remove the Flatbed.

1. Remove Chuter Unit.

(1) Referring to Section 5-8-1 "Chuter Unit (ADF Paper Chute)," remove the Chuter Unit.

2. Remove Control PCA.

(2) Referring to step (2) of Section 5-11 "Control PCA," remove the Control PCA.

3. Remove Base Unit.

(3) Referring to steps (3) ~ (8) of Section 5-9-1 "Base Unit," separate the Upper Unit and Base Unit.

4. Remove OPT Unit.

(4) Referring to step (4) of Section 5-9-6 "OPT Unit (for front side)," remove the OPT Unit.

<Installation>

Follow the above procedure in reverse.

Note: Re-install the OPT Unit.

Note: Do NOT pinch the cables.

Note: Base ASSY includes Pick roller. Referring to Section 7-3-4 "Pick roller replacement," reset the Pick roller counter.

Note: Perform the following adjustments after replacing the parts.

- Referring to Section 6-1-3 "Maintenance Mode #2," adjust the magnification.
- Referring to Section 6-1-4 "Maintenance Mode #3," adjust the offset.
- Referring to Section 6-1-5 "Maintenance Mode #4," adjust the white level.

Note: Clean the glass surface after replacing the part.

						TITLE	fi-6140/fi-6240/fi-6130/fi-6230/fi-614PR Maintenance Manual		
08	July 27, 09	K.Okada	A.Miyoshi	I.Fujioka	Refer to Revision Record on page 2.	DRAW No.	P1PA03540-B0XX/6	CUST.	
07	Nov.12, 08	K.Okada	T.Anzai	I.Fujioka	Refer to Revision Record on page 2.				
06	Mar.10, 08	K.Okada	T.Anzai	I.Fujioka	Refer to Revision Record on page 2.				
Rev.	DATE	DESIGN	CHECK	APPR.	DESCRIPTION	PFU LIMITED		Page	84 / 257
Design	July 27, 2007	K.Okada	CHECK	K.Okada		APPR.	T.Anzai		

5-9-3 Inverter (for front side scanning)

NOTICE

Refer to Section 3-3 for the part number of the replacement part.

<Removal>

Remove the imprinter (option)

fi-6140/fi-6130 with Imprinter Referring to Section 8-6-4 “Removing Imprinter”, remove the Imprinter.

Remove Flatbed.

fi-6240/fi-6230 Referring to Section 5-7 “Removing Flatbed,” remove the Flatbed.

1. Remove Chuter Unit.

(1) Referring to Section 5-8-1 “Chuter Unit (ADF Paper Chute),” remove the Chuter Unit.

2. Remove Control PCA.

(2) Referring to step (2) of Section 5-11 “Control PCA,” remove the Control PCA.

3. Remove Base Unit Cover.

(3) Referring to steps (3) ~ (7) of Section 5-9-1 “Base Unit,” remove the Base Unit Cover.

4. Remove Inverter.

(4) - Pushing the claw (square below) of the Inverter outward ①, draw out the Inverter ②.

- Disconnect two cables (circles below) of the Inverter.

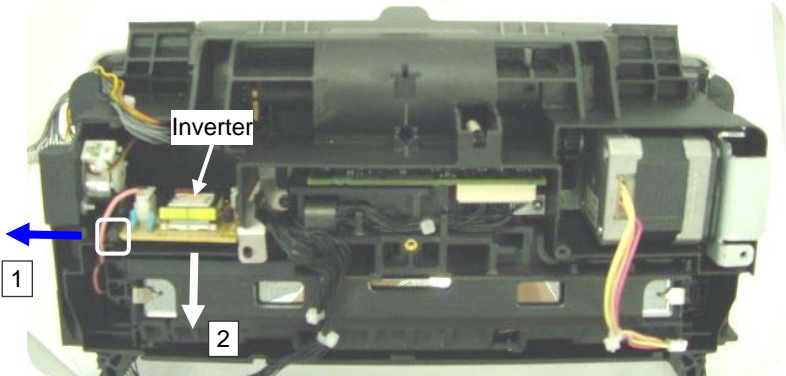

						TITLE	fi-6140/fi-6240/fi-6130/fi-6230/fi-614PR Maintenance Manual		
08	July 27, 09	K.Okada	A.Miyoshi	I.Fujioka	Refer to Revision Record on page 2.	DRAW	No.	P1PA03540-B0XX/6	CUST.
07	Nov.12, 08	K.Okada	T.Anzai	I.Fujioka	Refer to Revision Record on page 2.				
06	Mar.10, 08	K.Okada	T.Anzai	I.Fujioka	Refer to Revision Record on page 2.				
Rev.	DATE	DESIGN	CHECK	APPR.	DESCRIPTION	PFU LIMITED		Page	85 / 257
Design	July 27, 2007	K.Okada	CHECK	K.Okada		APPR.	T.Anzai		

<Installation>

Follow the removing procedure in reverse.

Wire the Lamp cable as shown below.

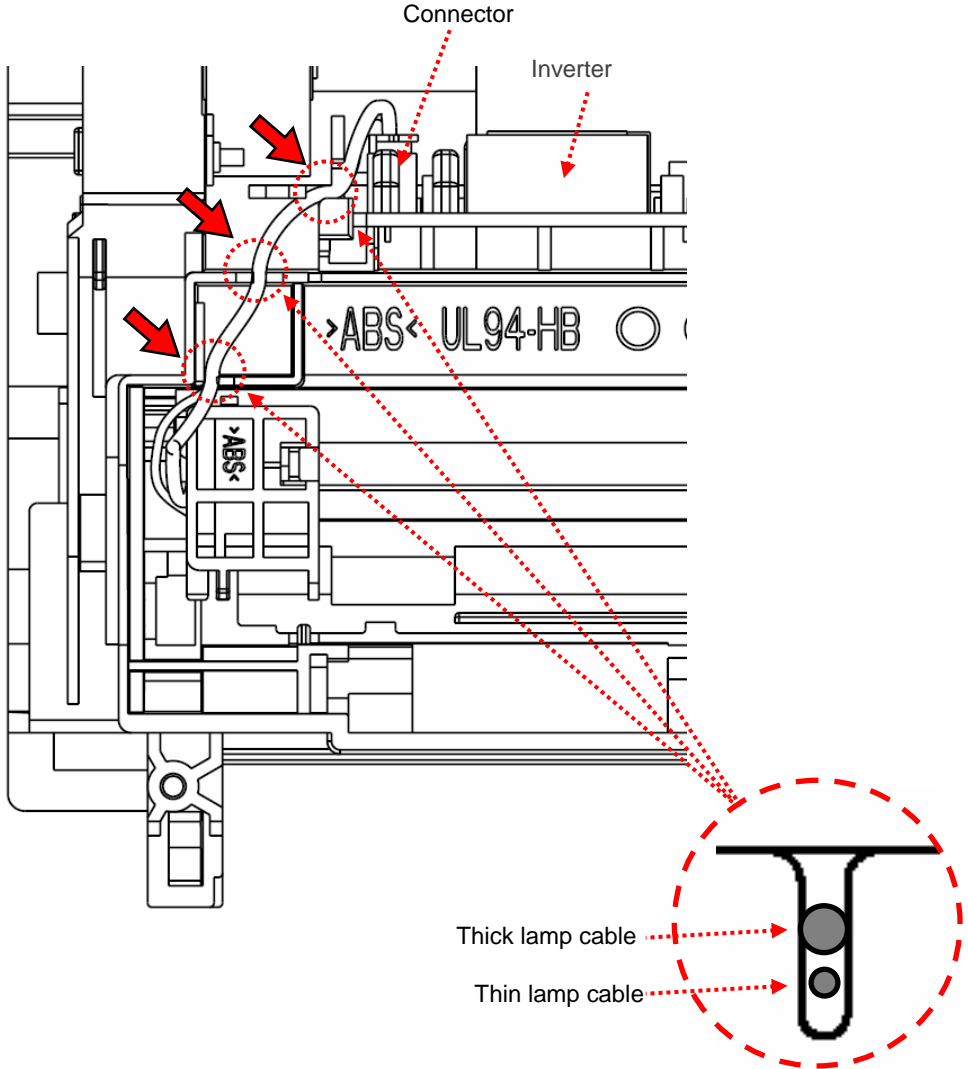

Note: Perform the following adjustments after replacing the parts.
 - Referring to Section 6-1-3 “Maintenance Mode #2,” adjust the magnification.
 - Referring to Section 6-1-4 “Maintenance Mode #3,” adjust the offset.
 - Referring to Section 6-1-5 “Maintenance Mode #4,” adjust the white level.

						TITLE	fi-6140/fi-6240/fi-6130/fi-6230/fi-614PR Maintenance Manual		
08	July 27, 09	K.Okada	A.Miyoshi	I.Fujioka	Refer to Revision Record on page 2.	DRAW	P1PA03540-B0XX/6	CUST.	
07	Nov.12, 08	K.Okada	T.Anzai	I.Fujioka	Refer to Revision Record on page 2.	No.			
06	Mar.10, 08	K.Okada	T.Anzai	I.Fujioka	Refer to Revision Record on page 2.				
Rev.	DATE	DESIGN	CHECK	APPR.	DESCRIPTION	PFU LIMITED		Page	86 / 257
Design	July 27, 2007	K.Okada	CHECK	K.Okada		APPR.	T.Anzai		

5-9-4 Lamp (for front side scanning)

NOTICE

Refer to Section 3-4 for the part number of the replacement part.

<Removal>

Remove the imprinter (option)

fi-6140/fi-6130 with Imprinter Referring to Section 8-6-4 “Removing Imprinter”, remove the Imprinter.

Remove Flatbed.

fi-6240/fi-6230 Referring to Section 5-7 “Removing Flatbed,” remove the Flatbed.

1. Remove Chuter Unit.

(1) Referring to Section 5-8-1 “Chuter Unit (ADF Paper Chute),” remove the Chuter Unit.

2. Remove Control PCA.

(2) Referring to step (2) of Section 5-11 “Control PCA,” remove the Control PCA.

3. Remove Base Unit Cover.

(3) Referring to steps (3) ~ (7) of Section 5-9-1 “Base Unit,” remove the Base Unit Cover.

4. Remove OPT Unit.

(4) Referring to step (4) of Section 5-9-6 “OPT Unit (for front side scanning),” remove the OPT Unit.

5. Remove Lamp.

(5) Unlatch seven claws (circles below) on the BK Cover to remove the BK Cover.

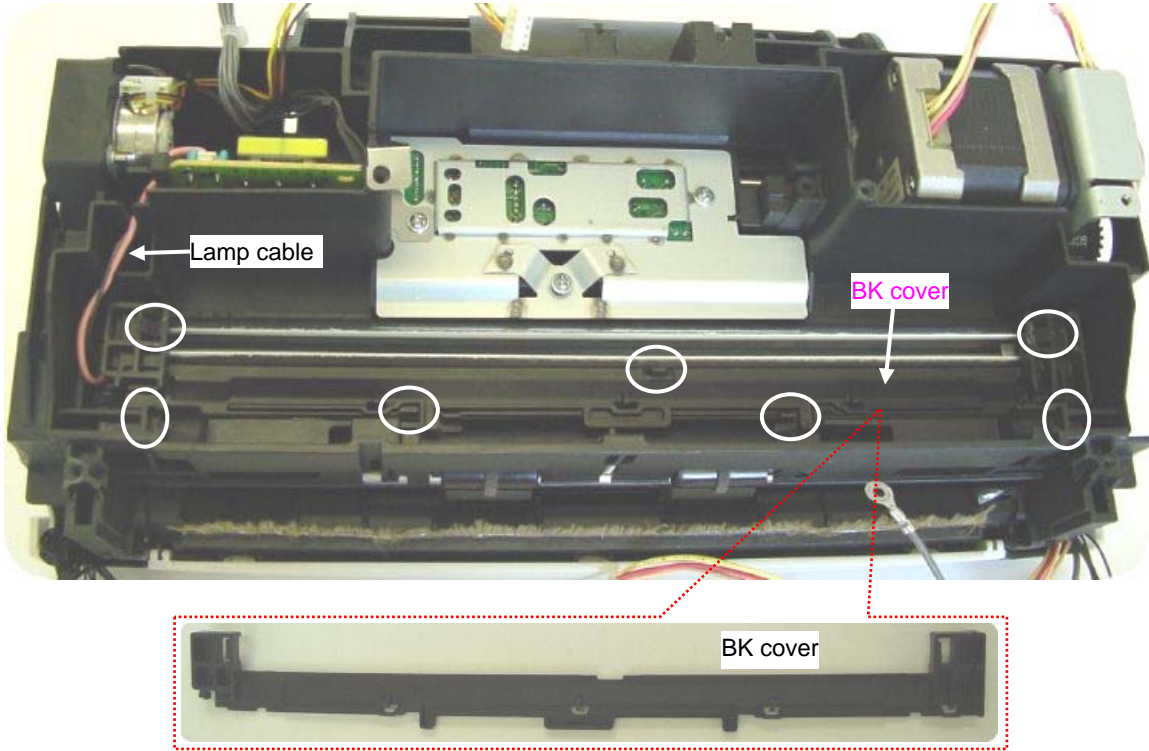

						TITLE	fi-6140/fi-6240/fi-6130/fi-6230/fi-614PR Maintenance Manual		
08	July 27, 09	K.Okada	A.Miyoshi	I.Fujioka	Refer to Revision Record on page 2.	DRAW No.	P1PA03540-B0XX/6	CUST.	
07	Nov.12, 08	K.Okada	T.Anzai	I.Fujioka	Refer to Revision Record on page 2.				
06	Mar.10, 08	K.Okada	T.Anzai	I.Fujioka	Refer to Revision Record on page 2.				
Rev.	DATE	DESIGN	CHECK	APPR.	DESCRIPTION	PFU LIMITED		Page	87 / 257
Design	July 27, 2007	K.Okada	CHECK	K.Okada		APPR.	T.Anzai		

- (6) – Lift up the reflector to remove. 1
- Unhook the thin lamp cable from the groove of the frame. 2
- Unhook the lamp cable from the Inverter (circle below), and then remove the Lamp. 3

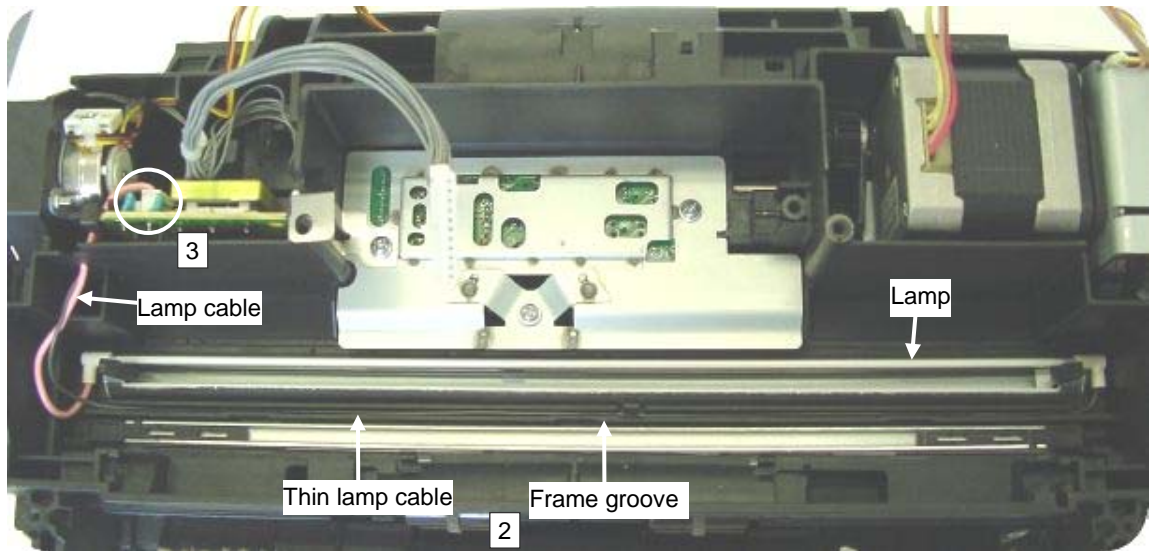
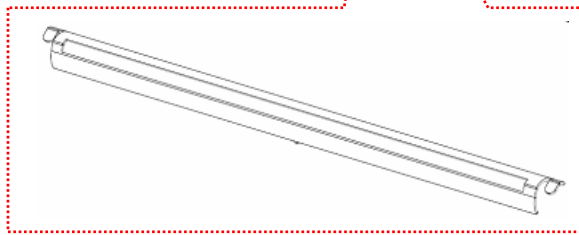
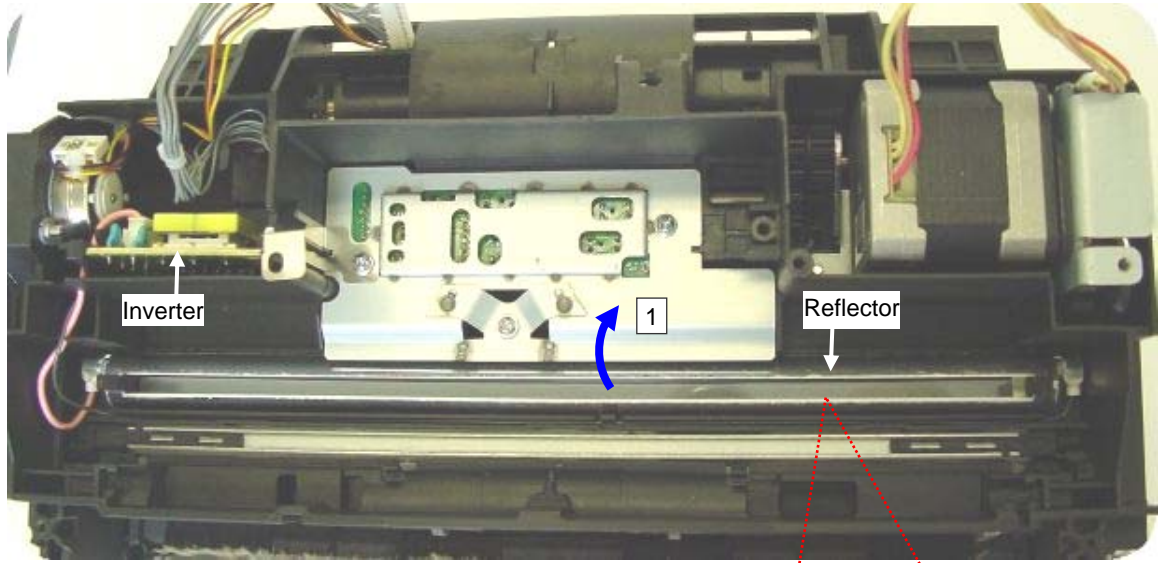

						TITLE	fi-6140/fi-6240/fi-6130/fi-6230/fi-614PR Maintenance Manual		
08	July 27, 09	K.Okada	A.Miyoshi	I.Fujioka	Refer to Revision Record on page 2.	DRAW	P1PA03540-B0XX/6	CUST.	
07	Nov.12, 08	K.Okada	T.Anzai	I.Fujioka	Refer to Revision Record on page 2.	No.			
06	Mar.10, 08	K.Okada	T.Anzai	I.Fujioka	Refer to Revision Record on page 2.				
Rev.	DATE	DESIGN	CHECK	APPR.	DESCRIPTION	PFU LIMITED		Page	88 / 257
Design	July 27, 2007	K.Okada	CHECK	K.Okada		APPR.	T.Anzai		

<Installation>

Follow the removing procedure in reverse.

Blow out the dust inside of the Glass and the OPT Unit with air before installation.

(1) Install the Lamp to the frame, and then route the thin Lamp cable on the groove of the frame.

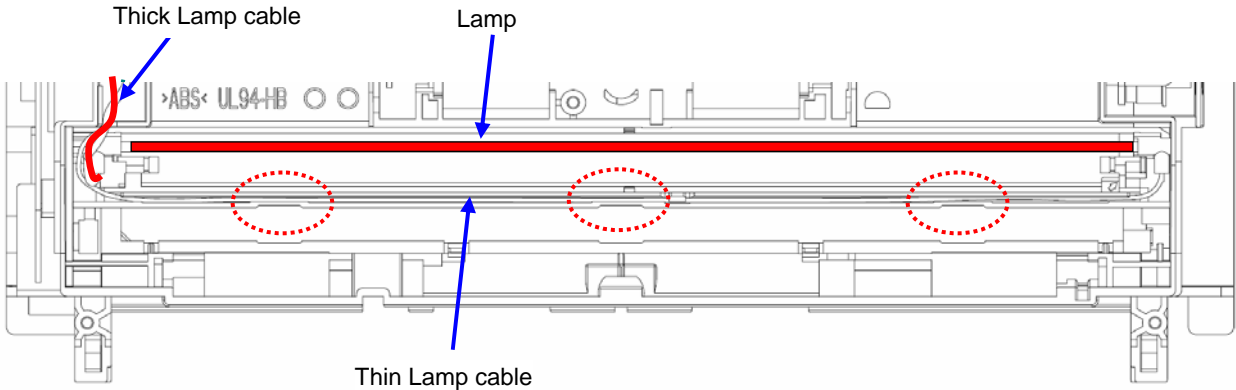

(2) Install the reflector to the frame.

Note: Make sure that the protrusions of the reflector are inserted into the holes of the frame.

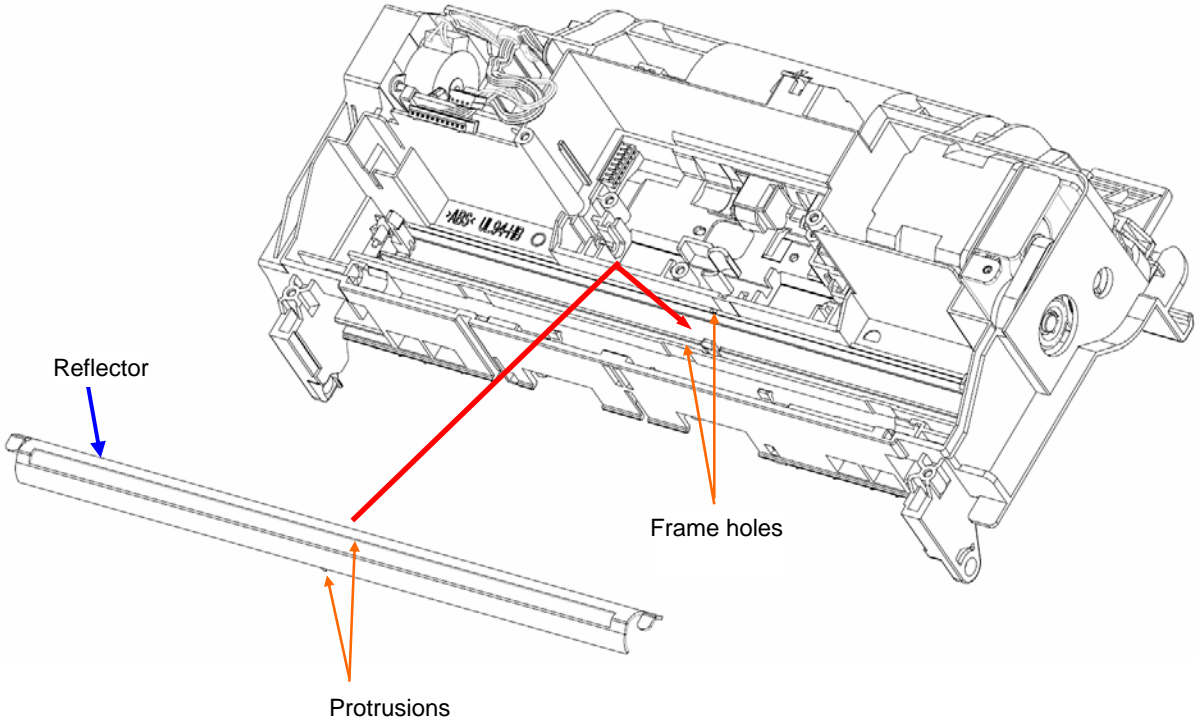

						TITLE	fi-6140/fi-6240/fi-6130/fi-6230/fi-614PR		
08	July 27, 09	K.Okada	A.Miyoshi	I.Fujioka	Refer to Revision Record on page 2.		Maintenance Manual		
07	Nov.12, 08	K.Okada	T.Anzai	I.Fujioka	Refer to Revision Record on page 2.	DRAW	P1PA03540-B0XX/6		CUST.
06	Mar.10, 08	K.Okada	T.Anzai	I.Fujioka	Refer to Revision Record on page 2.	No.			
Rev.	DATE	DESIGN	CHECK	APPR.	DESCRIPTION	PFU LIMITED		Page	89 / 257
Design	July 27, 2007	K.Okada	CHECK	K.Okada		APPR.	T.Anzai		

(3) Install the BK Cover to the frame.

Note: Make sure that seven claws are secured.

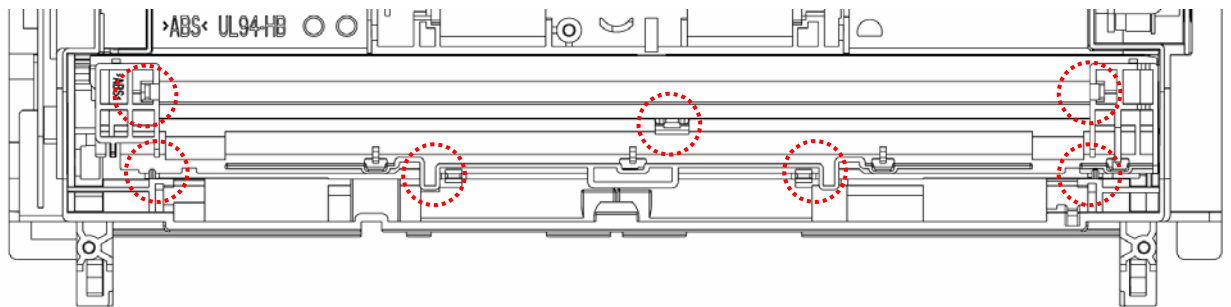
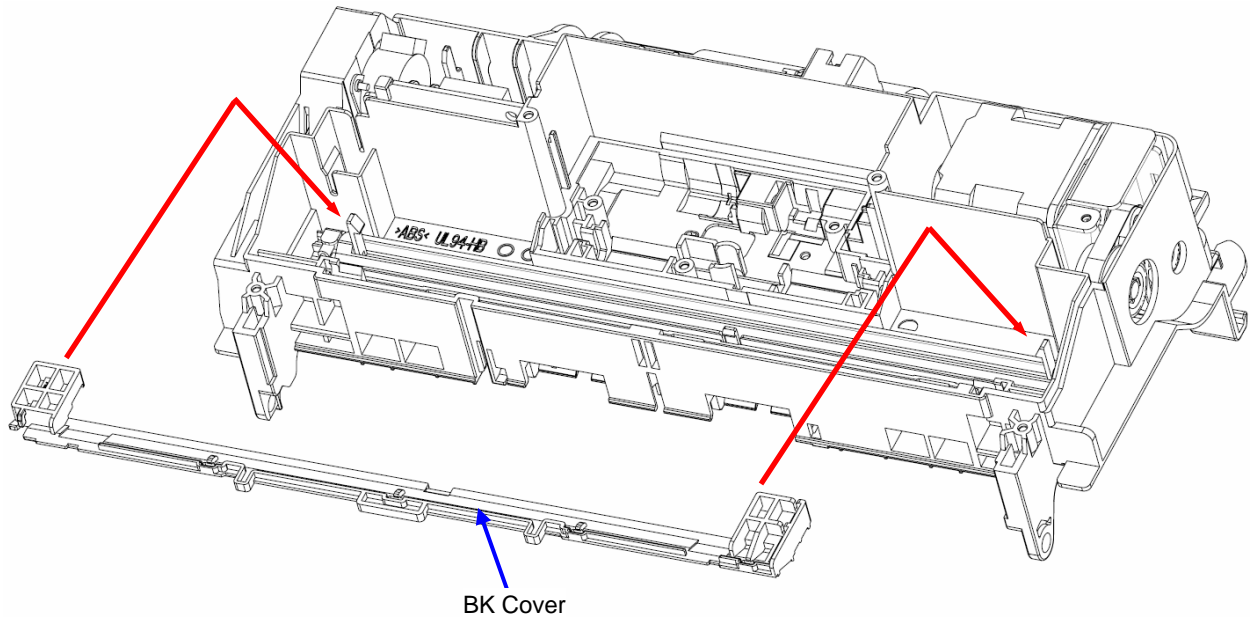

						TITLE	fi-6140/fi-6240/fi-6130/fi-6230/fi-614PR Maintenance Manual		
08	July 27, 09	K.Okada	A.Miyoshi	I.Fujioka	Refer to Revision Record on page 2.	DRAW	P1PA03540-B0XX/6	CUST.	
07	Nov.12, 08	K.Okada	T.Anzai	I.Fujioka	Refer to Revision Record on page 2.	No.			
06	Mar.10, 08	K.Okada	T.Anzai	I.Fujioka	Refer to Revision Record on page 2.				
Rev.	DATE	DESIGN	CHECK	APPR.	DESCRIPTION	PFU LIMITED		Page	90 / 257
Design	July 27, 2007	K.Okada	CHECK	K.Okada		APPR.	T.Anzai		

(4) Connect the Lamp cable to the Inverter (circle below).

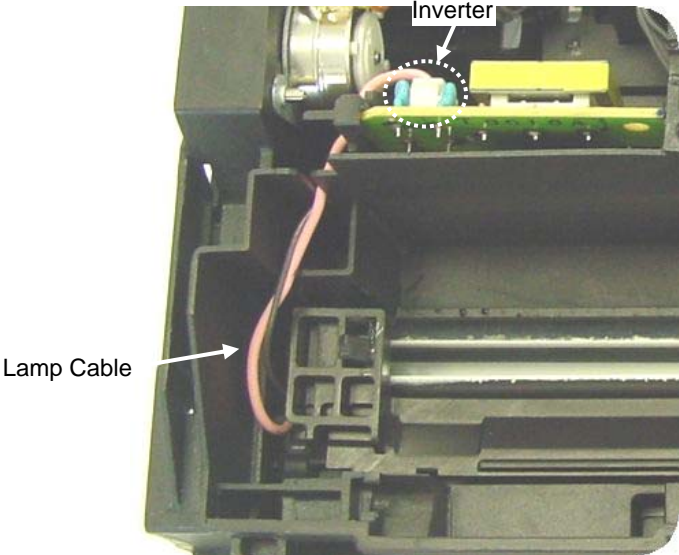

						TITLE	fi-6140/fi-6240/fi-6130/fi-6230/fi-614PR Maintenance Manual		
08	July 27, 09	K.Okada	A.Miyoshi	I.Fujioka	Refer to Revision Record on page 2.	DRAW	P1PA03540-B0XX/6	CUST.	
07	Nov.12, 08	K.Okada	T.Anzai	I.Fujioka	Refer to Revision Record on page 2.	No.			
06	Mar.10, 08	K.Okada	T.Anzai	I.Fujioka	Refer to Revision Record on page 2.				
Rev.	DATE	DESIGN	CHECK	APPR.	DESCRIPTION	PFU LIMITED		Page	91 / 257
Design	July 27, 2007	K.Okada	CHECK	K.Okada		APPR.	T.Anzai		

Wire the Lamp cable as shown below.

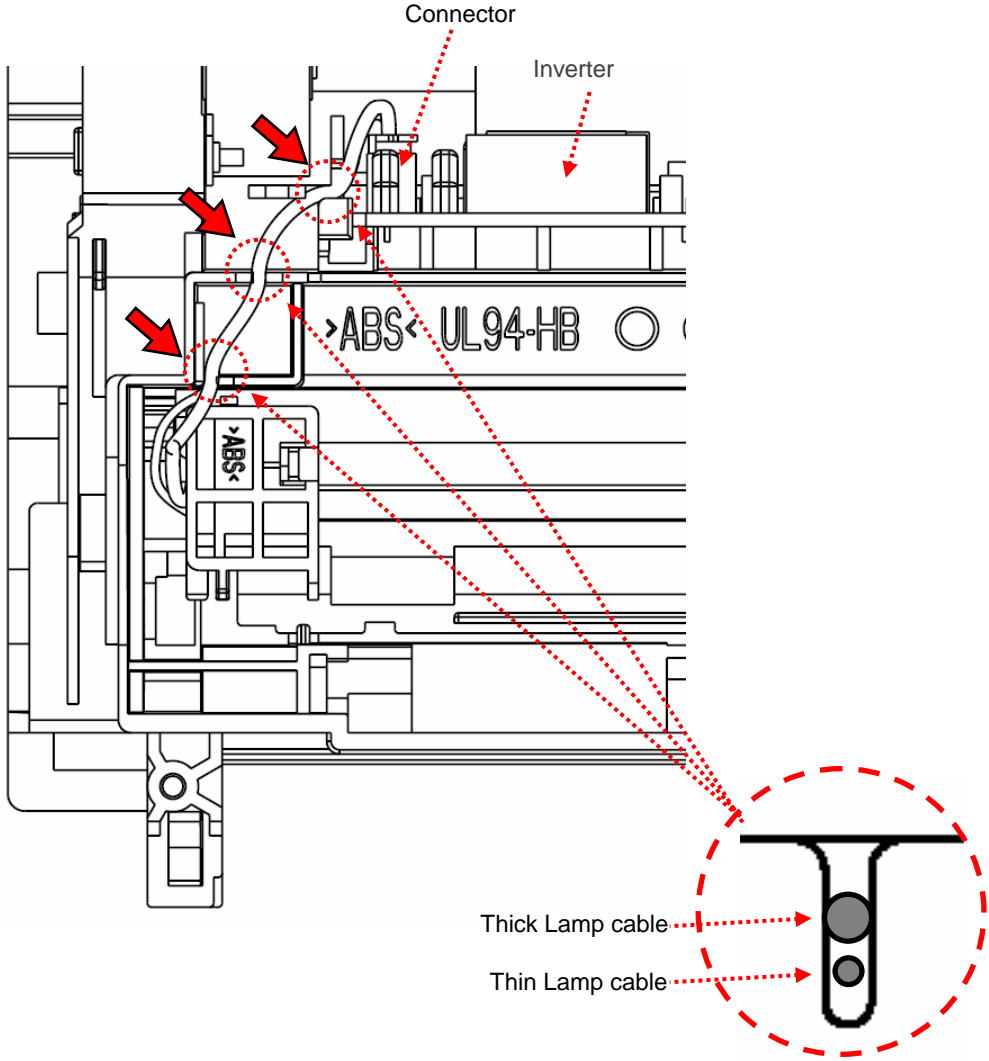

Note: Perform the following adjustments after replacing the parts.
 - Referring to Section 6-1-3 “Maintenance Mode #2,” adjust the magnification.
 - Referring to Section 6-1-4 “Maintenance Mode #3,” adjust the offset.
 - Referring to Section 6-1-5 “Maintenance Mode #4,” adjust the white level.

						TITLE	fi-6140/fi-6240/fi-6130/fi-6230/fi-614PR Maintenance Manual		
08	July 27, 09	K.Okada	A.Miyoshi	I.Fujioka	Refer to Revision Record on page 2.	DRAW	P1PA03540-B0XX/6	CUST.	
07	Nov.12, 08	K.Okada	T.Anzai	I.Fujioka	Refer to Revision Record on page 2.	No.			
06	Mar.10, 08	K.Okada	T.Anzai	I.Fujioka	Refer to Revision Record on page 2.				
Rev.	DATE	DESIGN	CHECK	APPR.	DESCRIPTION	PFU LIMITED		Page	92 / 257
Design	July 27, 2007	K.Okada	CHECK	K.Okada		APPR.	T.Anzai		

5-9-5 US Sensor FX (Multifeed detection)

NOTICE

- Refer to Section 3-5 for the part number of the replacement part.
- Refer to Appendix for the specification of the screws.

<Removal>

Remove the imprinter (option).

fi-6140/fi-6130 with Imprinter Referring to Section 8-6-4 “Removing Imprinter”, remove the Imprinter.

Remove Flatbed.

fi-6240/fi-6230 Referring to Section 5-7 “Removing Flatbed,” remove the Flatbed.

1. Remove Chuter Unit.

(1) Referring to Section 5-8-1 “Chuter Unit (ADF Paper Chute),” remove the Chuter Unit.

2. Remove Control PCA.

(2) Referring to step (2) of Section 5-11 “Control PCA,” remove the Control PCA.

3. Remove Base Unit Cover.

(3) Referring to steps (3) ~ (7) of Section 5-9-1 “Base Unit,” remove the Base Unit Cover.

4. Remove OPT Unit.

(4) Referring to step (4) of Section 5-9-6 “OPT Unit (for front side scanning),” remove the OPT Unit.

5. Remove US Sensor FX.

(5) Remove three screws A (circles below) of the US Shield and the FG plate, and then remove the US Shield.

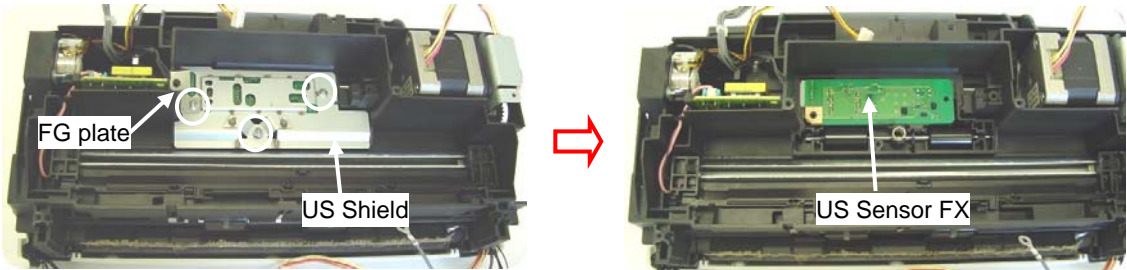

(6) Disconnect the US Sensor FX cable (circle below), and then remove the US Sensor FX.

Note: Do not pull the cable too hard.

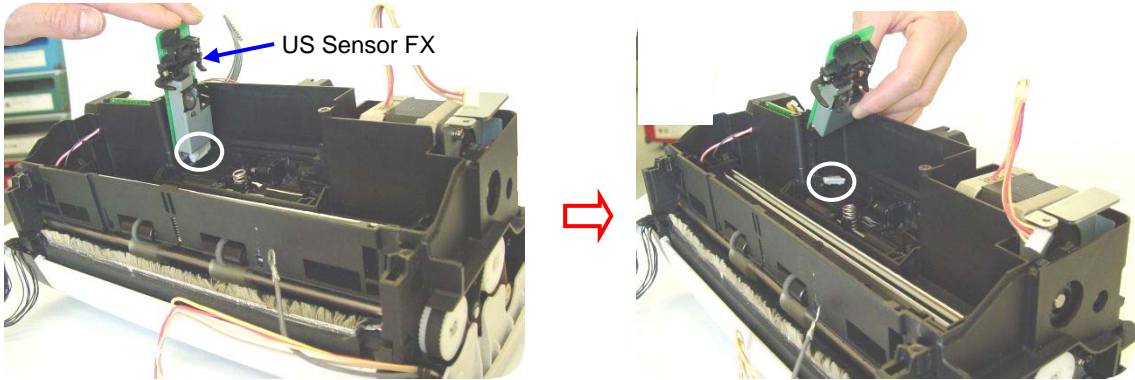

						TITLE	fi-6140/fi-6240/fi-6130/fi-6230/fi-614PR Maintenance Manual		
08	July 27, 09	K.Okada	A.Miyoshi	I.Fujioka	Refer to Revision Record on page 2.	DRAW	P1PA03540-B0XX/6	CUST.	
07	Nov.12, 08	K.Okada	T.Anzai	I.Fujioka	Refer to Revision Record on page 2.	No.			
06	Mar.10, 08	K.Okada	T.Anzai	I.Fujioka	Refer to Revision Record on page 2.				
Rev.	DATE	DESIGN	CHECK	APPR.	DESCRIPTION	PFU LIMITED		Page	93 / 257
Design	July 27, 2007	K.Okada	CHECK	K.Okada		APPR.	T.Anzai		

<Installation>

Follow the removing procedure in reverse.

Blow out the dust inside of the Glass and the OPT Unit with air before installation.

Wire the US Sensor FX cable as shown below.

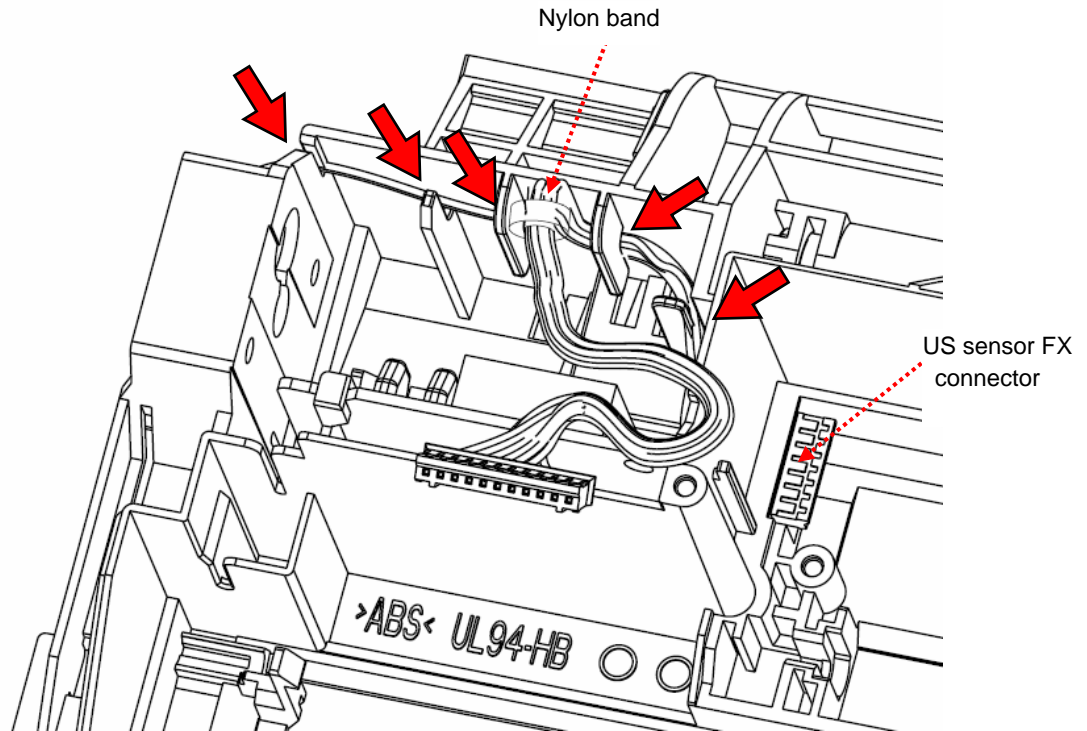

						TITLE	fi-6140/fi-6240/fi-6130/fi-6230/fi-614PR Maintenance Manual		
08	July 27, 09	K.Okada	A.Miyoshi	I.Fujioka	Refer to Revision Record on page 2.	DRAW	P1PA03540-B0XX/6	CUST.	
07	Nov.12, 08	K.Okada	T.Anzai	I.Fujioka	Refer to Revision Record on page 2.	No.			
06	Mar.10, 08	K.Okada	T.Anzai	I.Fujioka	Refer to Revision Record on page 2.				
Rev.	DATE	DESIGN	CHECK	APPR.	DESCRIPTION	PFU LIMITED		Page	94 / 257
Design	July 27, 2007	K.Okada	CHECK	K.Okada		APPR.	T.Anzai		

08

Note: Install the US Sensor FX as shown in the illustration below.
 (Install the spring spacer as shown below.)

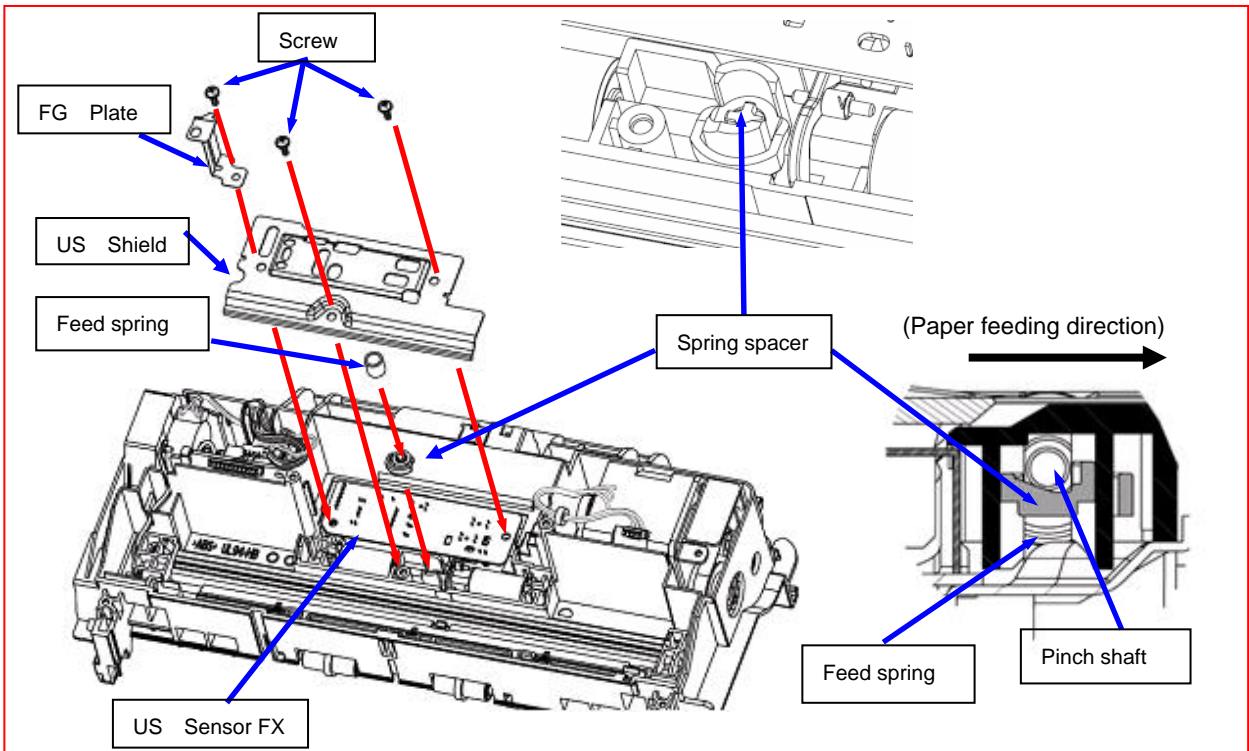

Note: Referring to Section 6-1-2 “Maintenance Mode #1,” check the sensor operation.

Note: Perform the following adjustments after replacing the parts.

- Referring to Section 6-1-3 “Maintenance Mode #2,” adjust the magnification.
- Referring to Section 6-1-4 “Maintenance Mode #3,” adjust the offset.
- Referring to Section 6-1-5 “Maintenance Mode #4,” adjust the white level.

						TITLE	fi-6140/fi-6240/fi-6130/fi-6230/fi-614PR		
08	July 27, 09	K.Okada	A.Miyoshi	I.Fujioka	Refer to Revision Record on page 2.		Maintenance Manual		
07	Nov.12, 08	K.Okada	T.Anzai	I.Fujioka	Refer to Revision Record on page 2.	DRAW	P1PA03540-B0XX/6		CUST.
06	Mar.10, 08	K.Okada	T.Anzai	I.Fujioka	Refer to Revision Record on page 2.	No.			
Rev.	DATE	DESIGN	CHECK	APPR.	DESCRIPTION	PFU LIMITED		Page	95 / 257
Design	July 27, 2007	K.Okada	CHECK	K.Okada		APPR.	T.Anzai		

5-9-6 OPT Unit (for front side scanning)

NOTICE

- Refer to Section 3-6 for the part number of the replacement part.
- Refer to Appendix for the specification of the screws.

<Removal>

Remove the imprinter (option)

fi-6140/fi-6130 with Imprinter Referring to Section 8-6-4 “Removing Imprinter”, remove the Imprinter.

Remove Flatbed.

fi-6240/fi-6230 Referring to Section 5-7 “Removing Flatbed,” remove the Flatbed.

1. Remove Chuter Unit.

(1) Referring to Section 5-8-1 “Chuter Unit (ADF Paper Chute),” remove the Chuter Unit.

2. Remove Control PCA.

(2) Referring to step (2) of Section 5-11 “Control PCA,” remove the Control PCA.

3. Remove Base Unit Cover. **03**

(3) Referring to steps (3) ~ (7) of Section 5-9-1 “Base Unit,” remove the Base Unit Cover.

4. Remove OPT Unit.

- (4) - Remove the screw A (circle below) on the OPT Hold plate, and then remove the OPT Hold plate. **1**
 - Lift up the OPT Unit at 45 degrees **2** to remove. **3**

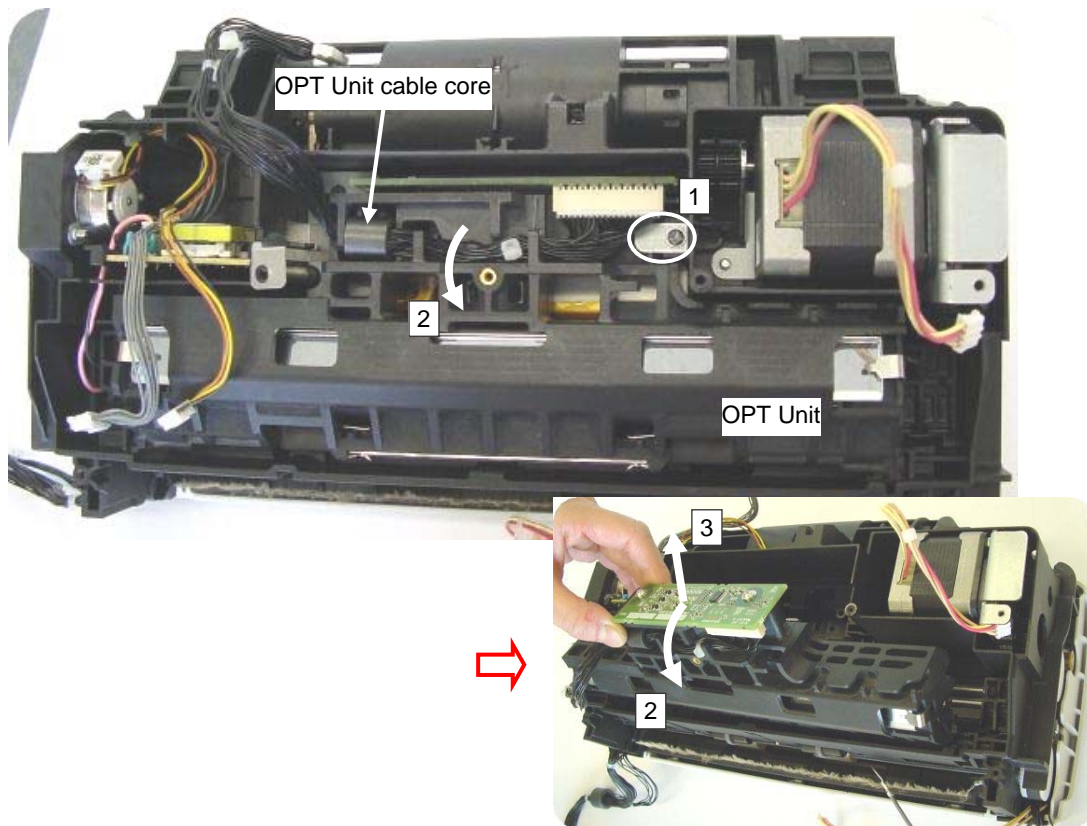

						TITLE	fi-6140/fi-6240/fi-6130/fi-6230/fi-614PR Maintenance Manual		
08	July 27, 09	K.Okada	A.Miyoshi	I.Fujioka	Refer to Revision Record on page 2.	DRAW	P1PA03540-B0XX/6	CUST.	
07	Nov.12, 08	K.Okada	T.Anzai	I.Fujioka	Refer to Revision Record on page 2.	No.			
06	Mar.10, 08	K.Okada	T.Anzai	I.Fujioka	Refer to Revision Record on page 2.				
Rev.	DATE	DESIGN	CHECK	APPR.	DESCRIPTION	PFU LIMITED		Page	96 / 257
Design	July 27, 2007	K.Okada	CHECK	K.Okada		APPR.	T.Anzai		

(5) Disconnect the CCD cable.

Note: Pinching the root of connector of the CCD board to support, pull out the CCD cable straight.

<Installation>

Follow the removing procedure in reverse.

Blow out the dust inside of the Glass and the OPT Unit with air before installation.

Install the OPT Unit in the order of 1 → 2.

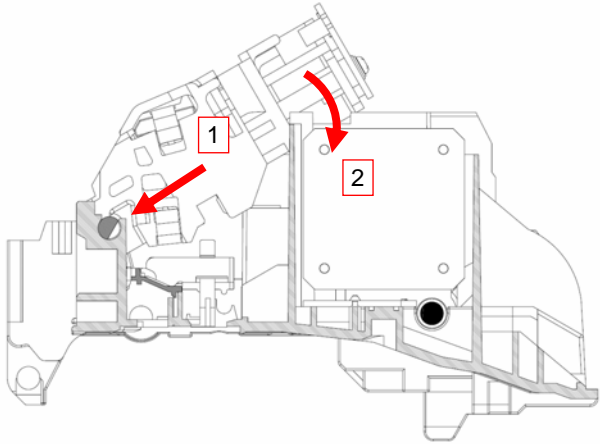

Note: Face the convex side down when installing the OPT Hold Plate.

Note: Perform the following adjustments after replacing the parts.
 - Referring to Section 6-1-3 “Maintenance Mode #2,” adjust the magnification.
 - Referring to Section 6-1-4 “Maintenance Mode #3,” adjust the offset.
 - Referring to Section 6-1-5 “Maintenance Mode #4,” adjust the white level.

						TITLE	fi-6140/fi-6240/fi-6130/fi-6230/fi-614PR		
08	July 27, 09	K.Okada	A.Miyoshi	I.Fujioka	Refer to Revision Record on page 2.		Maintenance Manual		
07	Nov.12, 08	K.Okada	T.Anzai	I.Fujioka	Refer to Revision Record on page 2.	DRAW	P1PA03540-B0XX/6	CUST.	
06	Mar.10, 08	K.Okada	T.Anzai	I.Fujioka	Refer to Revision Record on page 2.	No.			
Rev.	DATE	DESIGN	CHECK	APPR.	DESCRIPTION	PFU LIMITED		Page	97 / 257
Design	July 27, 2007	K.Okada	CHECK	K.Okada		APPR.	T.Anzai		

5-9-7 BW Motor

NOTICE

- Refer to Section 3-7 for the part number of the replacement part.
- Refer to Appendix for the specification of the screws.

<Removal>

Remove the imprinter (option).

fi-6140/fi-6130 with Imprinter Referring to Section 8-6-4 “Removing Imprinter”, remove the Imprinter.

Remove Flatbed.

fi-6240/fi-6230 Referring to Section 5-7 “Removing Flatbed,” remove the Flatbed.

1. Remove Chuter Unit.

(1) Referring to Section 5-8-1 “Chuter Unit (ADF Paper Chute),” remove the Chuter Unit.

2. Remove Control PCA.

(2) Referring to step (2) of Section 5-11 “Control PCA,” remove the Control PCA.

3. Remove Base Unit Cover.

(3) Referring to steps (3) ~ (7) of Section 5-9-1 “Base Unit,” remove the Base Unit Cover.

4. Remove BW Motor.

(4) Remove two screws E (circles below) of the BW Motor.

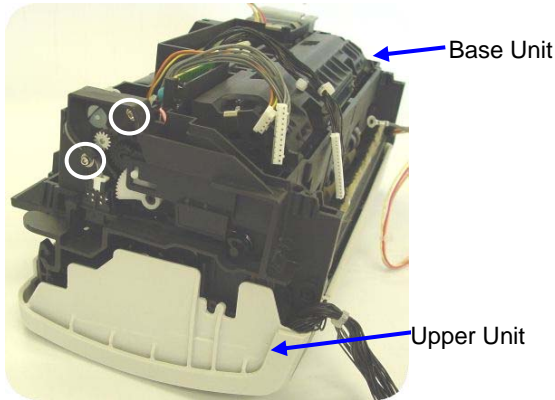

(5) Remove the BW Motor.

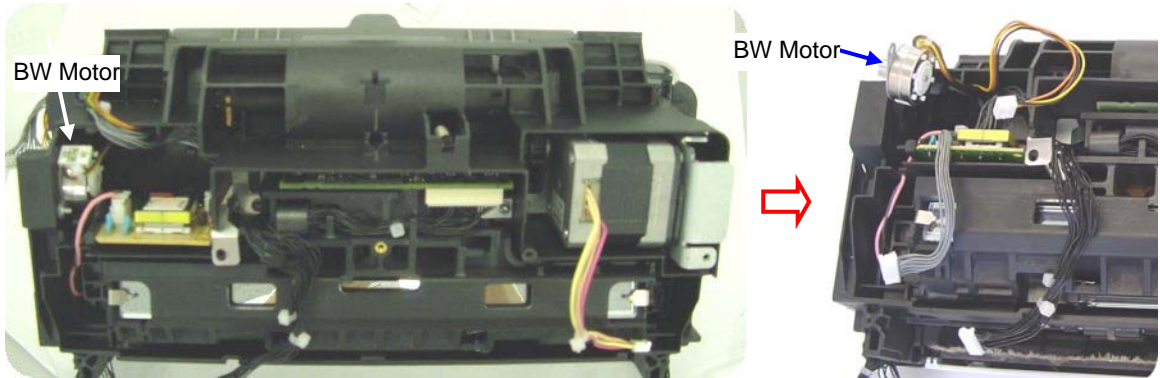

						TITLE	fi-6140/fi-6240/fi-6130/fi-6230/fi-614PR Maintenance Manual		
08	July 27, 09	K.Okada	A.Miyoshi	I.Fujioka	Refer to Revision Record on page 2.	DRAW	P1PA03540-B0XX/6	CUST.	
07	Nov.12, 08	K.Okada	T.Anzai	I.Fujioka	Refer to Revision Record on page 2.	No.			
06	Mar.10, 08	K.Okada	T.Anzai	I.Fujioka	Refer to Revision Record on page 2.				
Rev.	DATE	DESIGN	CHECK	APPR.	DESCRIPTION	PFU LIMITED		Page	98 / 257
Design	July 27, 2007	K.Okada	CHECK	K.Okada		APPR.	T.Anzai		

<Installation>

Follow the removing procedure in reverse.

Note: Perform the following adjustments after replacing the parts.

- Referring to Section 6-1-3 “Maintenance Mode #2,” adjust the magnification.
- Referring to Section 6-1-4 “Maintenance Mode #3,” adjust the offset.
- Referring to Section 6-1-5 “Maintenance Mode #4,” adjust the white level.

						TITLE	fi-6140/fi-6240/fi-6130/fi-6230/fi-614PR Maintenance Manual		
08	July 27, 09	K.Okada	A.Miyoshi	I.Fujioka	Refer to Revision Record on page 2.	DRAW No.	P1PA03540-B0XX/6	CUST.	
07	Nov.12, 08	K.Okada	T.Anzai	I.Fujioka	Refer to Revision Record on page 2.				
06	Mar.10, 08	K.Okada	T.Anzai	I.Fujioka	Refer to Revision Record on page 2.				
Rev.	DATE	DESIGN	CHECK	APPR.	DESCRIPTION	PFU LIMITED		Page	99 / 257
Design	July 27, 2007	K.Okada	CHECK	K.Okada		APPR.	T.Anzai		

5-9-8 Guide P ASSY (Sheet Guide)

NOTICE

Refer to Section 3-8 for the part number of the replacement part.

<Removal>

1. Remove Chuter Unit.

(1) Referring to Section 5-8-1 “Chuter Unit (ADF Paper Chute),” remove the Chuter Unit.

2. Remove Guide P ASSY.

(2) Open the Upper Unit.

(3) - Lifting up the grip of the Guide P ASSY **1**, open the Guide P ASSY.

Note: Remove the Paper protection roller from the Guide P ASSY.

- Bow the center (dotted square below) of the Guide P ASSY **2**, and unlatch the pin (circle below) at the right side of the Guide P ASSY. **3**
- Unlatch the pin (solid square below) at the left side of the Guide P ASSY. **4**

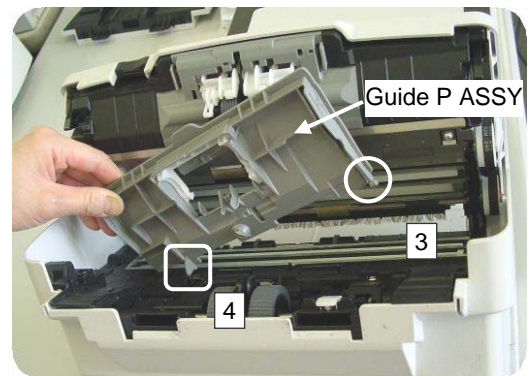
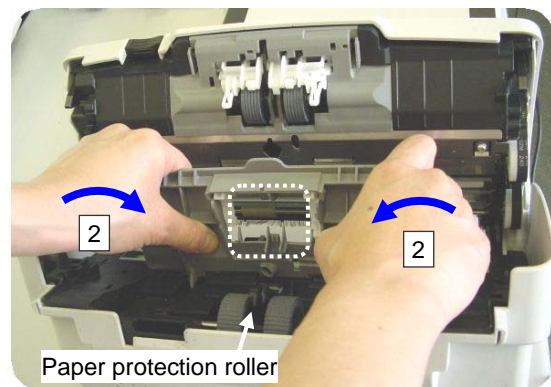
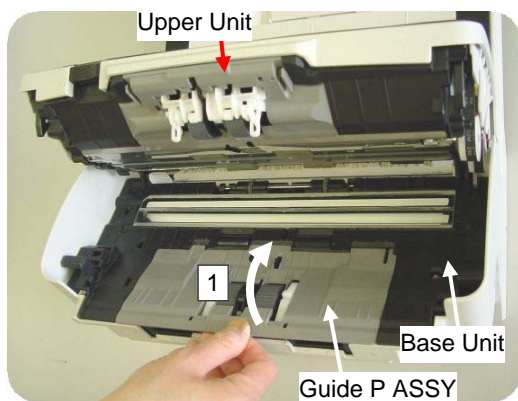

<Installation>

Follow the removing procedure in reverse.

						TITLE	fi-6140/fi-6240/fi-6130/fi-6230/fi-614PR Maintenance Manual		
08	July 27, 09	K.Okada	A.Miyoshi	I.Fujioka	Refer to Revision Record on page 2.	DRAW	P1PA03540-B0XX/6	CUST.	
07	Nov.12, 08	K.Okada	T.Anzai	I.Fujioka	Refer to Revision Record on page 2.	No.			
06	Mar.10, 08	K.Okada	T.Anzai	I.Fujioka	Refer to Revision Record on page 2.				
Rev.	DATE	DESIGN	CHECK	APPR.	DESCRIPTION	PFU LIMITED		Page	100 / 257
Design	July 27, 2007	K.Okada	CHECK	K.Okada		APPR.	T.Anzai		

5-9-9 PICK Motor ASSY

NOTICE

- Refer to Section 3-9 for the part number of the replacement part.
- Refer to Appendix for the specification of the screws.

<Removal>

Remove the imprinter (option).

fi-6140/fi-6130 with Imprinter Referring to Section 8-6-4 “Removing Imprinter”, remove the Imprinter.

Remove Flatbed.

fi-6240/fi-6230 Referring to Section 5-7 “Removing Flatbed,” remove the Flatbed.

1. Remove Chuter Unit.

(1) Referring to Section 5-8-1 “Chuter Unit (ADF Paper Chute),” remove the Chuter Unit.

2. Remove Control PCA.

(2) Referring to step (2) of Section 5-11 “Control PCA,” remove the Control PCA.

3. Remove Base Unit Cover.

(3) Referring to steps (3) ~ (7) of Section 5-9-1 “Base Unit,” remove the Base Unit Cover.

4. Remove Guide P ASSY.

(4) Referring to steps (2) ~ (3) of Section 5-9-8 “Guide P ASSY (Sheet Guide),” remove the Guide P ASSY (Sheet Guide).

5. Remove PICK Motor ASSY.

- (5) - Open the Upper Unit.
- Remove two screws C (circles below) of the PICK Motor ASSY.

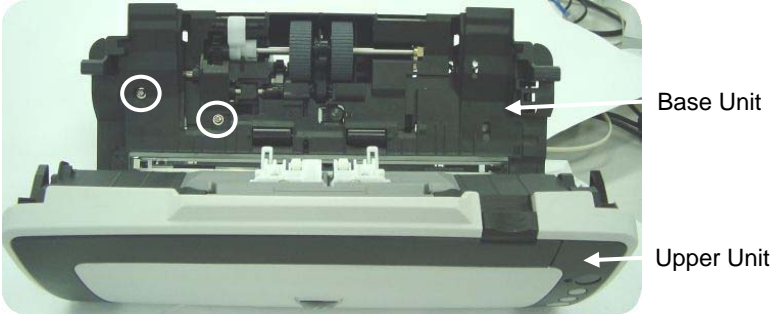

- (6) - Draw the PICK Motor ASSY out of the Base Unit.

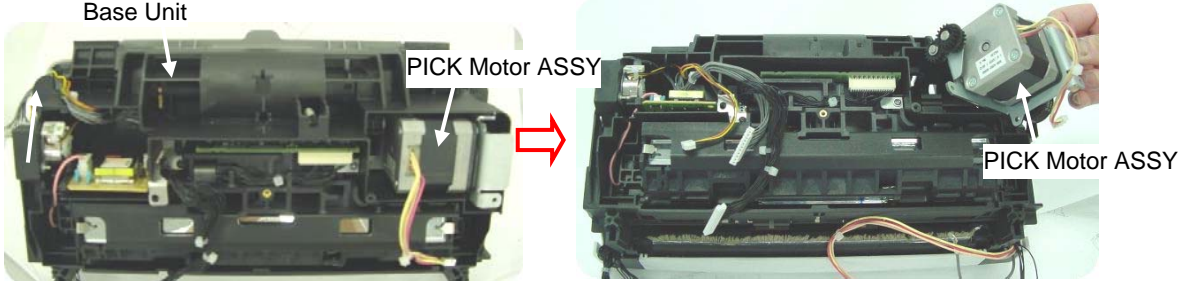

						TITLE	fi-6140/fi-6240/fi-6130/fi-6230/fi-614PR Maintenance Manual			
08	July 27, 09	K.Okada	A.Miyoshi	I.Fujioka	Refer to Revision Record on page 2.	DRAW No.	P1PA03540-B0XX/6	Page	101 / 257	
07	Nov.12, 08	K.Okada	T.Anzai	I.Fujioka	Refer to Revision Record on page 2.					CUST.
06	Mar.10, 08	K.Okada	T.Anzai	I.Fujioka	Refer to Revision Record on page 2.					
Rev.	DATE	DESIGN	CHECK	APPR.	DESCRIPTION	PFU LIMITED				
Design	July 27, 2007	K.Okada	CHECK	K.Okada		APPR.	T.Anzai			

<Installation>

Follow the removing procedure in reverse.

Note: To confirm that the Pick Motor ASSY falls into the positioning boss, make sure that the centers of the gear pulleys come to the center of the frame.

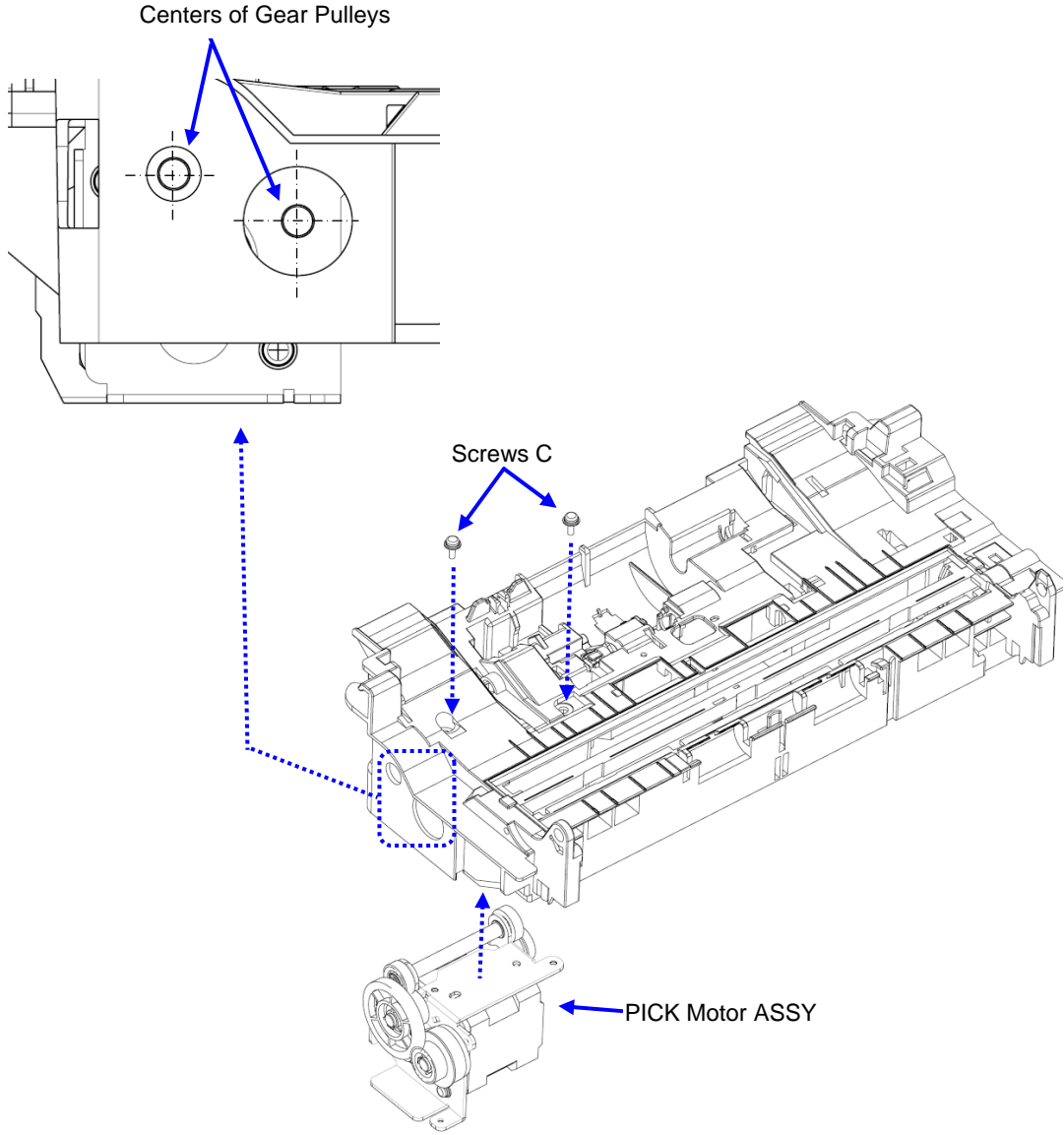

						TITLE	fi-6140/fi-6240/fi-6130/fi-6230/fi-614PR Maintenance Manual		
08	July 27, 09	K.Okada	A.Miyoshi	I.Fujioka	Refer to Revision Record on page 2.	DRAW	P1PA03540-B0XX/6	CUST.	
07	Nov.12, 08	K.Okada	T.Anzai	I.Fujioka	Refer to Revision Record on page 2.	No.			
06	Mar.10, 08	K.Okada	T.Anzai	I.Fujioka	Refer to Revision Record on page 2.				
Rev.	DATE	DESIGN	CHECK	APPR.	DESCRIPTION	PFU LIMITED		Page	102 / 257
Design	July 27, 2007	K.Okada	CHECK	K.Okada		APPR.	T.Anzai		

5-9-10 PICK Motor

NOTICE

- Refer to Section 3-10 for the part number of the replacement part.
- Refer to Appendix for the specification of the screws.

<Removal>

Remove the imprinter (option).

fi-6140/fi-6130 with Imprinter Referring to Section 8-6-4 “Removing Imprinter”, remove the Imprinter.

Remove Flatbed.

fi-6240/fi-6230 Referring to Section 5-7 “Removing Flatbed,” remove the Flatbed.

1. Remove Chuter Unit.

(1) Referring to Section 5-8-1 “Chuter Unit (ADF Paper Chute),” remove the Chuter Unit.

2. Remove Control PCA.

(2) Referring to step (2) of Section 5-11 “Control PCA,” remove the Control PCA.

3. Remove Base Unit Cover.

(3) Referring to steps (3) ~ (7) of Section 5-9-1 “Base Unit,” remove the Base Unit Cover.

4. Remove Guide P ASSY.

(4) Referring to steps (2) ~ (3) of Section 5-9-8 “Guide P ASSY (Sheet Guide),” remove the Guide P ASSY (Sheet Guide).

5. Remove PICK Motor ASSY.

(5) Referring to (5) ~ (6) of Section 5-9-9, remove the PICK Motor ASSY.

6. Remove PICK Motor.

- (6) - Insert the flat-blade screwdriver into the gap of the claw on the gear. 1
- Tilt the flat-blade screwdriver inward of the gear to unlatch the claw, and then remove the gear. 2
- Remove two screws C (circles below) on the PICK Motor, and then remove the PICK Motor. 3

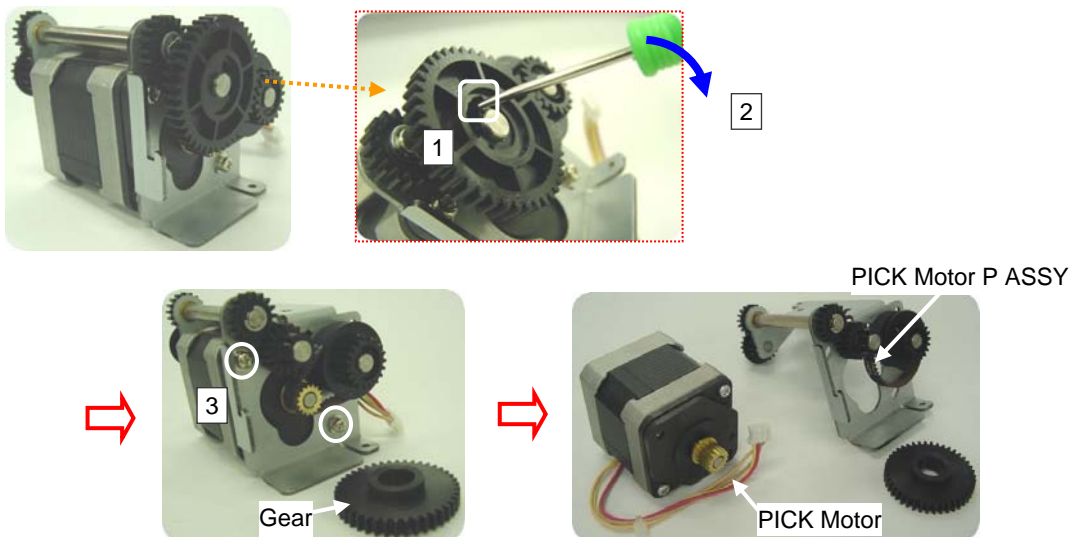

						TITLE	fi-6140/fi-6240/fi-6130/fi-6230/fi-614PR Maintenance Manual		
08	July 27, 09	K.Okada	A.Miyoshi	I.Fujioka	Refer to Revision Record on page 2.	DRAW	P1PA03540-B0XX/6	CUST.	
07	Nov.12, 08	K.Okada	T.Anzai	I.Fujioka	Refer to Revision Record on page 2.	No.			
06	Mar.10, 08	K.Okada	T.Anzai	I.Fujioka	Refer to Revision Record on page 2.				
Rev.	DATE	DESIGN	CHECK	APPR.	DESCRIPTION	PFU LIMITED		Page	103 / 257
Design	July 27, 2007	K.Okada	CHECK	K.Okada		APPR.	T.Anzai		

<Installation>

Follow the above procedure in reverse.

Note: Adjust the PICK Motor belt tension.

- (1) - Place the belt tension adjusting spring that is attached to the Maintenance Part as shown below.
 - Place the PICK Motor downside. Holding the PICK Motor P ASSY, secure two screws C (circles below).
 - Remove the belt tension adjusting spring.

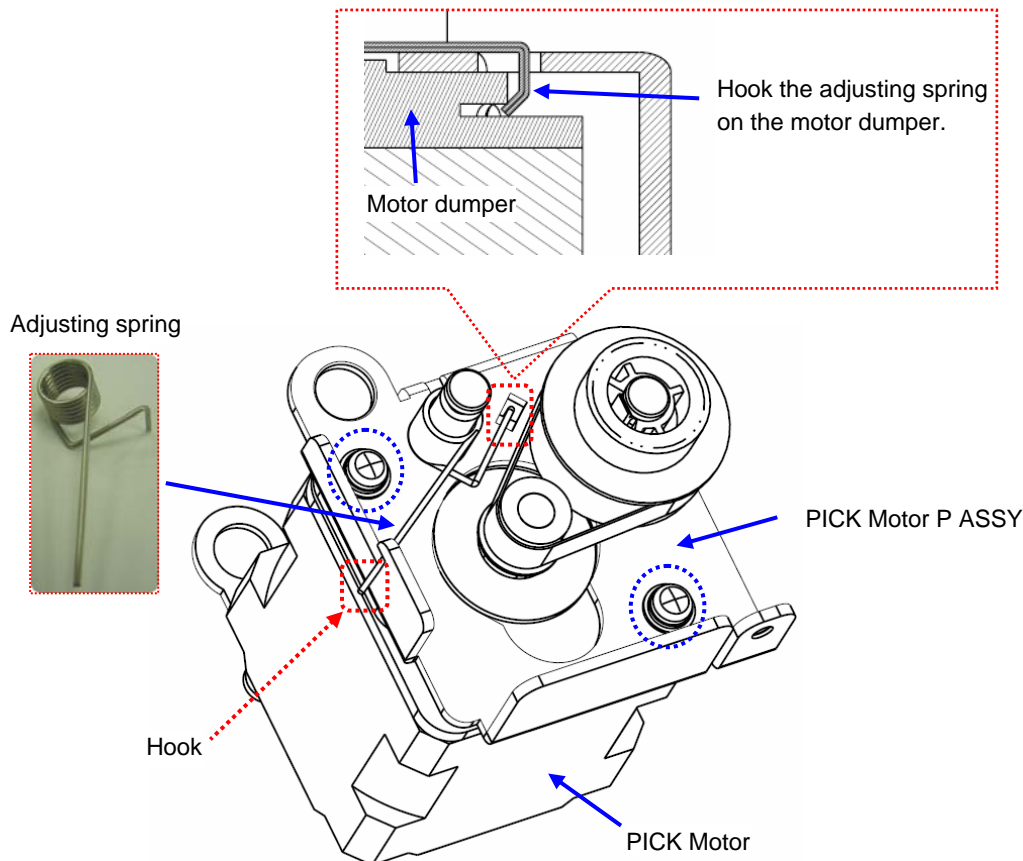

- (2) Check the belt tension.

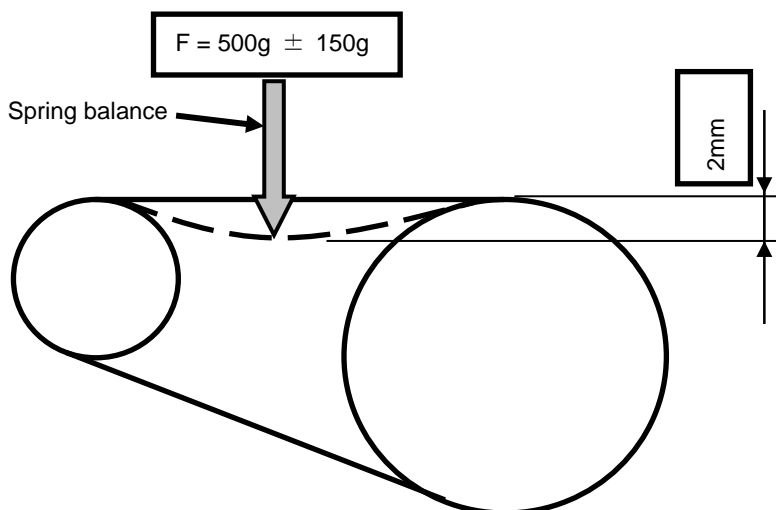

						TITLE	fi-6140/fi-6240/fi-6130/fi-6230/fi-614PR Maintenance Manual		
08	July 27, 09	K.Okada	A.Miyoshi	I.Fujioka	Refer to Revision Record on page 2.	DRAW	P1PA03540-B0XX/6	CUST.	
07	Nov.12, 08	K.Okada	T.Anzai	I.Fujioka	Refer to Revision Record on page 2.	No.			
06	Mar.10, 08	K.Okada	T.Anzai	I.Fujioka	Refer to Revision Record on page 2.				
Rev.	DATE	DESIGN	CHECK	APPR.	DESCRIPTION	PFU LIMITED		Page	104 / 257
Design	July 27, 2007	K.Okada	CHECK	K.Okada		APPR.	T.Anzai		

5-9-11 PICK Shaft ASSY

NOTICE

Refer to Section 3-11 for the part number of the replacement part.

<Removal>

1. Remove the PICK Shaft ASSY.

- (1) - Open the Upper Unit.
 - Lifting the grab of the Guide P ASSY (Sheet Guide), open the Guide P ASSY (Sheet Guide). **1**
 - Rotate the Pick roller lever in the direction of the arrow. **2**
 - Move the Pick roller lever in the direction of the arrow, lift it up and pull the shaft out of the hole. **3**

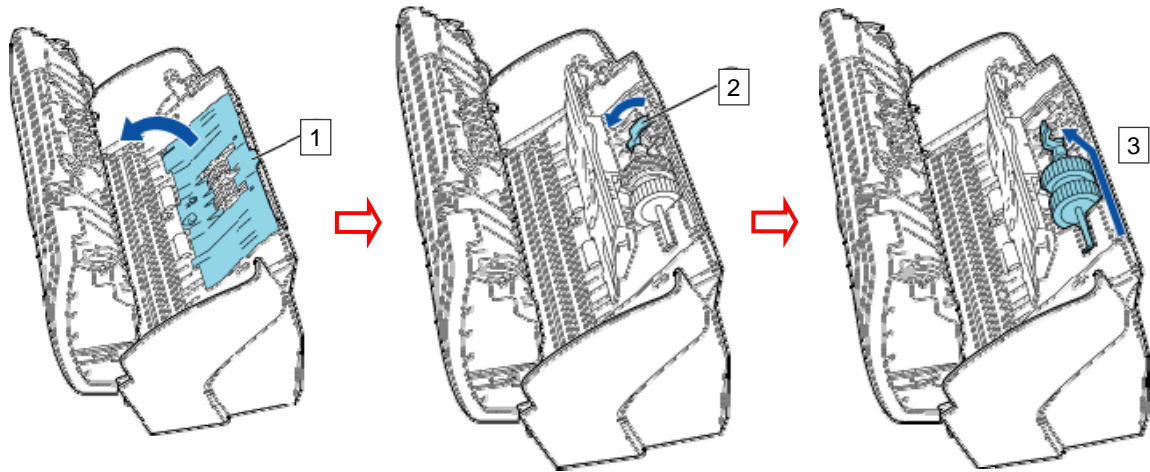

- (2) Remove the Pick roller from the shaft while lifting up the tab on the Pick roller.

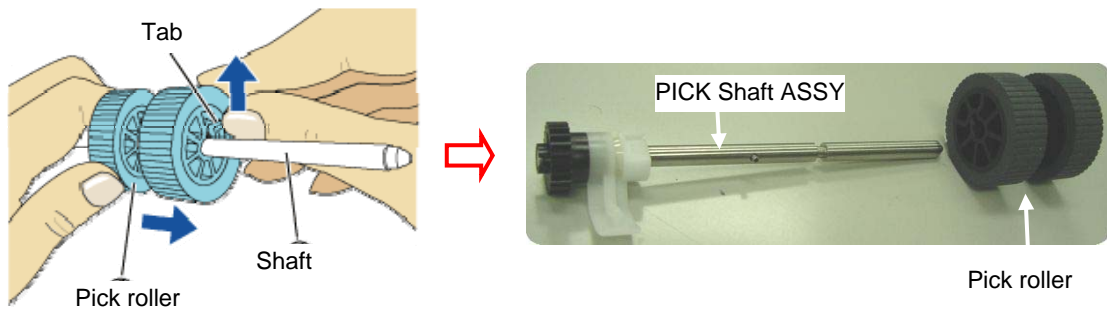

<Installation>

Follow the above procedure in reverse.

						TITLE	fi-6140/fi-6240/fi-6130/fi-6230/fi-614PR Maintenance Manual		
08	July 27, 09	K.Okada	A.Miyoshi	I.Fujioka	Refer to Revision Record on page 2.	DRAW	P1PA03540-B0XX/6	CUST.	
07	Nov.12, 08	K.Okada	T.Anzai	I.Fujioka	Refer to Revision Record on page 2.	No.			
06	Mar.10, 08	K.Okada	T.Anzai	I.Fujioka	Refer to Revision Record on page 2.				
Rev.	DATE	DESIGN	CHECK	APPR.	DESCRIPTION	PFU LIMITED		Page	105 / 257
Design	July 27, 2007	K.Okada	CHECK	K.Okada		APPR.	T.Anzai		

5-9-12 Switch (ADF open detection)

NOTICE

Refer to Section 3-12 for the parts number of the replacement part.

<Removal>

Remove the imprinter (option).

fi-6140/fi-6130 with Imprinter Referring to Section 8-6-4 “Removing Imprinter”, remove the Imprinter.

Remove Flatbed.

fi-6240/fi-6230 Referring to Section 5-7 “Removing Flatbed,” remove the Flatbed.

1. Remove Chuter Unit.

(1) Referring to Section 5-8-1 “Chuter Unit (ADF Paper Chute),” remove the Chuter Unit.

2. Remove Control PCA.

(2) Referring to step (2) of Section 5-11 “Control PCA,” remove the Control PCA.

3. Remove Base Unit Cover.

(3) Referring to steps (3) ~ (7) of Section 5-9-1 “Base Unit,” remove the Base Unit Cover.

4. Remove Switch.

(4) - Open the Upper Unit.

- Pushing the tabs at the both sides of the Switch **1**, move the Switch **2**, and then unlatch the tabs **3**.

- Remove the Switch, and then disconnect the Switch cable (square below).

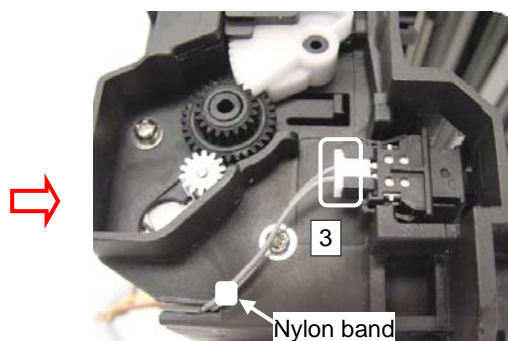
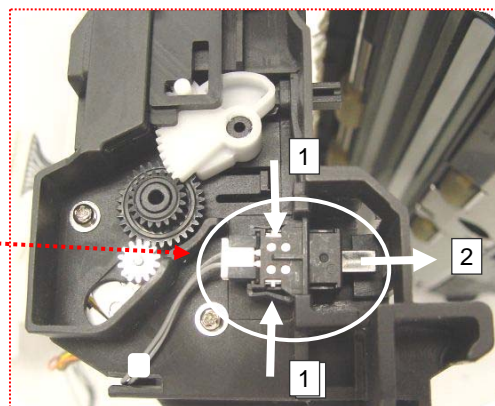
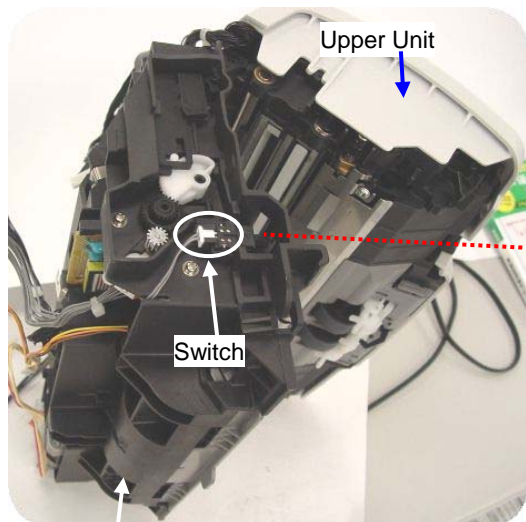

Base Unit

<Installation>

Follow the above procedure in reverse.

						TITLE	fi-6140/fi-6240/fi-6130/fi-6230/fi-614PR Maintenance Manual		
08	July 27, 09	K.Okada	A.Miyoshi	I.Fujioka	Refer to Revision Record on page 2.	DRAW No.	P1PA03540-B0XX/6		CUST.
07	Nov.12, 08	K.Okada	T.Anzai	I.Fujioka	Refer to Revision Record on page 2.				
06	Mar.10, 08	K.Okada	T.Anzai	I.Fujioka	Refer to Revision Record on page 2.				
Rev.	DATE	DESIGN	CHECK	APPR.	DESCRIPTION	PFU LIMITED		Page	106 / 257
Design	July 27, 2007	K.Okada	CHECK	K.Okada		APPR.	T.Anzai		

5-10 Upper Unit

5-10-1 Upper Unit

NOTICE

- The Panel PCA is not included.
- Re-install the Panel PCA.
- Do not touch the glass at the scanning area to prevent contamination at disassembling.
- Refer to Section 3-13 for the part number of the replacement part.

<Removal>

Remove the imprinter (option).

fi-6140/fi-6130 with Imprinter Referring to Section 8-6-4 “Removing Imprinter”, remove the Imprinter.

Remove Flatbed.

fi-6240/fi-6230 Referring to Section 5-7 “Removing Flatbed,” remove the Flatbed.

1. Remove Chuter Unit.

(1) Referring to Section 5-8-1 “Chuter Unit (ADF Paper Chute),” remove the Chuter Unit.

2. Remove Control PCA.

(2) Referring to step (2) of Section 5-11 “Control PCA,” remove the Control PCA.

3. Remove Upper Unit.

(3) Referring to steps (3) ~ (8) of Section 5-9-1 “Base Unit,” separate the Upper Unit and Base Unit.

4. Remove Panel PCA.

(4) Referring to Section 5-10-9 “Panel PCA,” remove the Panel PCA.

Note: There is no need to save the EEPROM data.

<Installation>

Follow the above procedure in reverse.

Note: Re-install the Panel PCA.

Note: Do NOT pinch the cables.

Note: Upper Unit includes Brake roller. Referring to Section 7-3-3 “Brake roller replacement,” reset the Brake roller counter.

Note: Perform the following adjustments after replacing the parts.

- Referring to Section 6-1-3 “Maintenance Mode #2,” adjust the magnification.
- Referring to Section 6-1-4 “Maintenance Mode #3,” adjust the offset.
- Referring to Section 6-1-5 “Maintenance Mode #4,” adjust the white level.

Note: Clean the glass surface after installation.

						TITLE	fi-6140/fi-6240/fi-6130/fi-6230/fi-614PR Maintenance Manual		
08	July 27, 09	K.Okada	A.Miyoshi	I.Fujioka	Refer to Revision Record on page 2.	DRAW No.	P1PA03540-B0XX/6	CUST.	
07	Nov.12, 08	K.Okada	T.Anzai	I.Fujioka	Refer to Revision Record on page 2.				
06	Mar.10, 08	K.Okada	T.Anzai	I.Fujioka	Refer to Revision Record on page 2.				
Rev.	DATE	DESIGN	CHECK	APPR.	DESCRIPTION	PFU LIMITED		Page	107 / 257
Design	July 27, 2007	K.Okada	CHECK	K.Okada		APPR.	T.Anzai		

5-10-2 Upper ASSY

 NOTICE

- The Panel PCA and the OPT Unit are not included.
- A dummy TOP Cover is included.
- Remove OPT Unit from Upper Unit. The remaining assembly is Upper ASSY.
- Re-install the Panel PCA, OPT Unit, and the TOP Cover.
- Refer to Section 3-14 for the part number of the replacement part.

<Removal>

Remove the imprinter (option).

fi-6140/fi-6130 with Imprinter Referring to Section 8-6-4 “Removing Imprinter”, remove the Imprinter.

Remove Flatbed.

fi-6240/fi-6230 Referring to Section 5-7 “Removing Flatbed,” remove the Flatbed.

1. Remove Chuter Unit.

(1) Referring to Section 5-8-1 “Chuter Unit (ADF Paper Chute),” remove the Chuter Unit.

2. Remove Control PCA.

(2) Referring to step (2) of Section 5-11 “Control PCA,” remove the Control PCA.

3. Remove Upper Unit.

(3) Referring to steps (3) ~ (8) of Section 5-9-1 “Base Unit,” separate the Upper Unit and Base Unit.

4. Remove Panel PCA.

(4) Referring to Section 5-10-8 “Panel PCA,” remove the Panel PCA.

Note: There is no need to save the EEPROM data.

5. Remove Top Cover.

(5) Referring to steps (3) ~ (5) of Section 5-10-11 “Top Cover,” remove the Top Cover.

6. Remove OPT Unit.

(6) Referring to step (4) of Section 5-10-4 “OPT Unit (for backside scanning),” remove the OPT Unit.

<Installation>

Follow the above procedure in reverse.

Note: Re-install the Panel PCA, OPT Unit, and Top Cover.

Note: Do NOT pinch the cables.

Note: Upper ASSY includes Brake roller. Referring to Section 7-3-3 “Brake roller replacement,” reset the Brake roller counter.

Note: Perform the following adjustments after replacing the parts.

- Referring to Section 6-1-3 “Maintenance Mode #2,” adjust the magnification.
- Referring to Section 6-1-4 “Maintenance Mode #3,” adjust the offset.
- Referring to Section 6-1-5 “Maintenance Mode #4,” adjust the white level.

Note: Clean the glass surface after replacing the part.

						TITLE	fi-6140/fi-6240/fi-6130/fi-6230/fi-614PR Maintenance Manual			
08	July 27, 09	K.Okada	A.Miyoshi	I.Fujioka	Refer to Revision Record on page 2.	DRAW No.	P1PA03540-B0XX/6	Page	108 / 257	
07	Nov.12, 08	K.Okada	T.Anzai	I.Fujioka	Refer to Revision Record on page 2.					CUST.
06	Mar.10, 08	K.Okada	T.Anzai	I.Fujioka	Refer to Revision Record on page 2.					
Rev.	DATE	DESIGN	CHECK	APPR.	DESCRIPTION	PFU LIMITED				
Design	July 27, 2007	K.Okada	CHECK	K.Okada		APPR.	T.Anzai			

5-10-3 ADF Motor

NOTICE

- Refer to Section 3-15 for the part number of the replacement part.
- Refer to Appendix for the specification of the screws.

<Removal>

1. Remove Chuter Unit.

(1) Referring to Section 5-8-1 “Chuter Unit (ADF Paper Chute),” remove the Chuter Unit.

2. Remove Control PCA.

(2) Referring to step (2) of Section 5-11 “Control PCA,” remove the Control PCA.

3. Remove Panel PCA cable.

(3) Referring to steps of Section 5-10-9 “Panel PCA,” disconnect the Panel PCA cable.

Note: There is no need to save EEPROM data.

4. Remove Top Cover.

(4) Referring to steps (3) ~ (5) of Section 5-10-11 “Top Cover,” remove the Top Cover.

5. Remove ADF Motor.

(5) Moving the ADF Motor cable side of the Base Unit cover LID at the bottom of the ADF to the front, remove the Base Unit Cover LID.

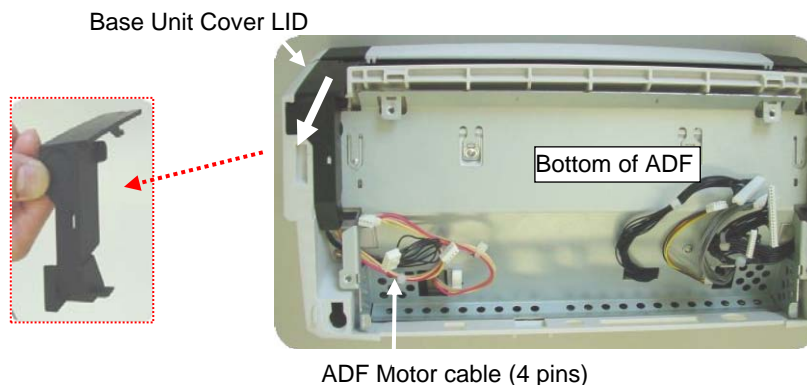

(6) Remove the ADF Motor cable from the frame hole at the bottom of the ADF. **02**

(7) Open the Upper Unit. **02**

(8) Unfasten the screw C (square below) of the belt tension bracket, and then remove the ADF Motor Belt. **02**

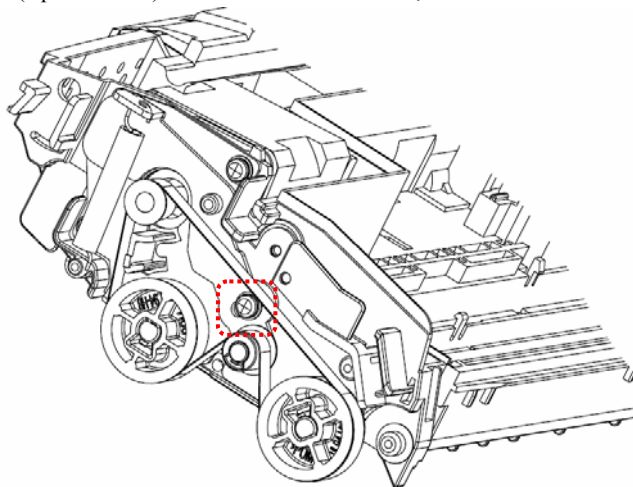

						TITLE	fi-6140/fi-6240/fi-6130/fi-6230/fi-614PR Maintenance Manual		
08	July 27, 09	K.Okada	A.Miyoshi	I.Fujioka	Refer to Revision Record on page 2.	DRAW No.	P1PA03540-B0XX/6	CUST.	
07	Nov.12, 08	K.Okada	T.Anzai	I.Fujioka	Refer to Revision Record on page 2.				
06	Mar.10, 08	K.Okada	T.Anzai	I.Fujioka	Refer to Revision Record on page 2.				
Rev.	DATE	DESIGN	CHECK	APPR.	DESCRIPTION	PFU LIMITED		Page	109 / 257
Design	July 27, 2007	K.Okada	CHECK	K.Okada		APPR.	T.Anzai		

(9) Remove two screws C (circles below) of the ADF Motor and FG spring, and then remove the ADF Motor. 02

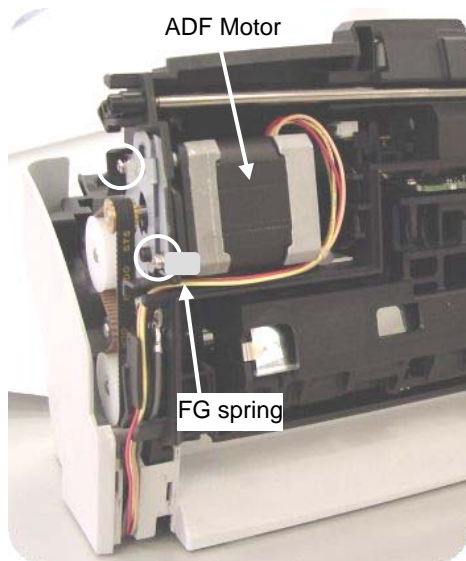

<Installation>

Follow the removing procedure in reverse.

Note: Do not forget to install the FG spring.

Note: When the left pulley is 90 degrees, the right pulley must be 45 ± 25 degrees.

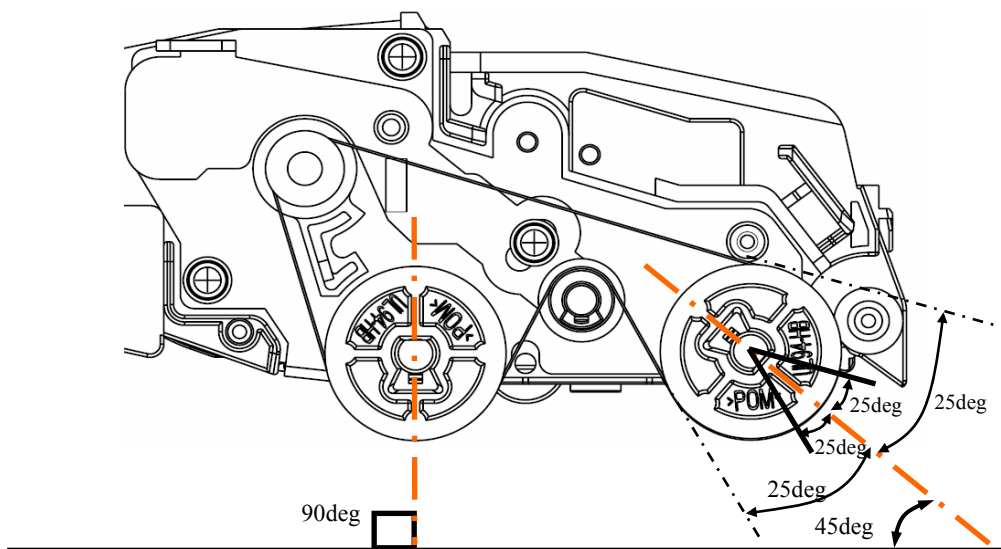

						TITLE	fi-6140/fi-6240/fi-6130/fi-6230/fi-614PR Maintenance Manual		
08	July 27, 09	K.Okada	A.Miyoshi	I.Fujioka	Refer to Revision Record on page 2.	DRAW	P1PA03540-B0XX/6	CUST.	
07	Nov.12, 08	K.Okada	T.Anzai	I.Fujioka	Refer to Revision Record on page 2.	No.			
06	Mar.10, 08	K.Okada	T.Anzai	I.Fujioka	Refer to Revision Record on page 2.				
Rev.	DATE	DESIGN	CHECK	APPR.	DESCRIPTION	PFU LIMITED		Page	110 / 257
Design	July 27, 2007	K.Okada	CHECK	K.Okada		APPR.	T.Anzai		

Note: Adjust the ADF Motor belt tension.

- (1) - Install the belt tension adjusting spring attached to the maintenance part as shown below.
 - Secure the screw C (square below).
 - Remove the belt tension adjusting spring.

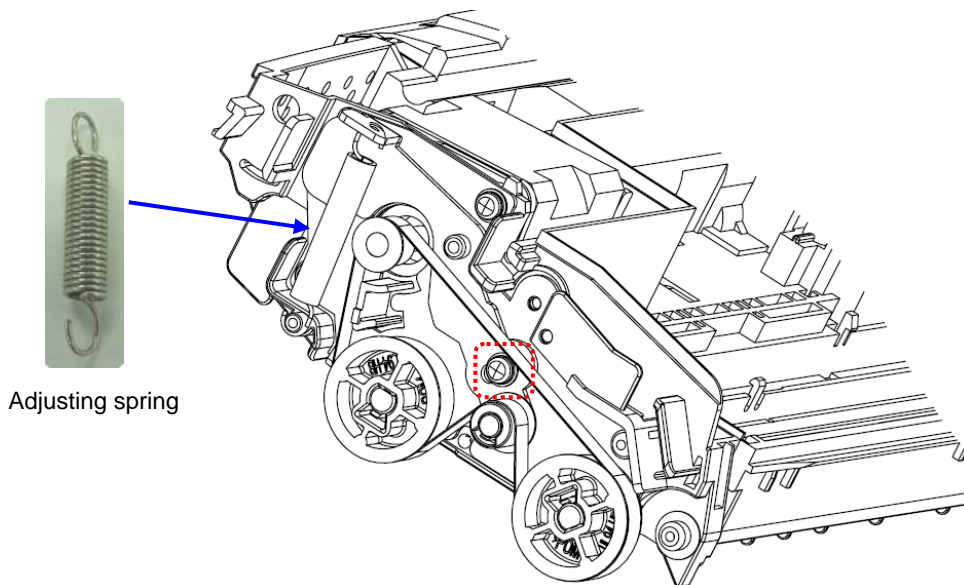

- (2) Check the belt tension.

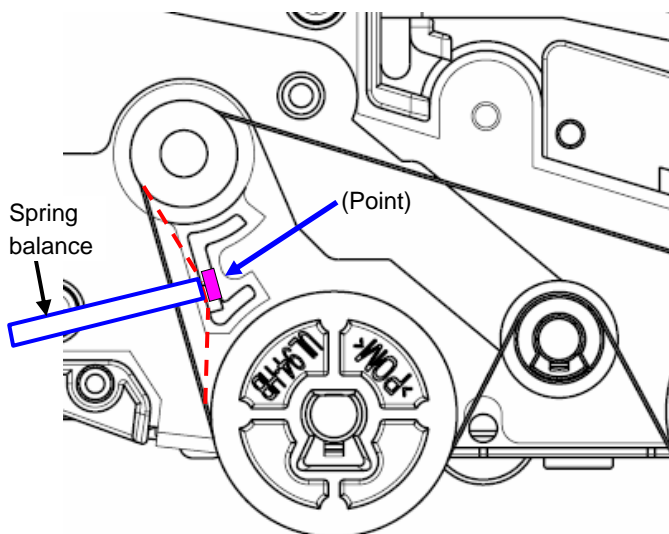

Tension when the spring balance touches the rib:
: 350gf ± 100gf 05

Note: Perform the following adjustments after replacing the parts.

- Referring to Section 6-1-3 “Maintenance Mode #2,” adjust the magnification.
- Referring to Section 6-1-4 “Maintenance Mode #3,” adjust the offset.
- Referring to Section 6-1-5 “Maintenance Mode #4,” adjust the white level.

Note: Clean the glass surface after replacing the part.

						TITLE	fi-6140/fi-6240/fi-6130/fi-6230/fi-614PR Maintenance Manual		
08	July 27, 09	K.Okada	A.Miyoshi	I.Fujioka	Refer to Revision Record on page 2.	DRAW	P1PA03540-B0XX/6	CUST.	
07	Nov.12, 08	K.Okada	T.Anzai	I.Fujioka	Refer to Revision Record on page 2.	No.			
06	Mar.10, 08	K.Okada	T.Anzai	I.Fujioka	Refer to Revision Record on page 2.				
Rev.	DATE	DESIGN	CHECK	APPR.	DESCRIPTION	PFU LIMITED		Page	111 / 257
Design	July 27, 2007	K.Okada	CHECK	K.Okada		APPR.	T.Anzai		

5-10-4 OPT Unit (for backside scanning)

NOTICE

- Refer to Section 3-6 for the part number of the replacement part.
- Refer to Appendix for the specification of the screws.

<Removal>

1. Remove Chuter Unit.

(1) Referring to Section 5-8-1 “Chuter Unit (ADF Paper Chute),” remove the Chuter Unit.

2. Remove Panel PCA cable.

(2) Referring to steps of Section 5-10-9 “Panel PCA,” disconnect the Panel PCA cable.

Note: There is no need to save EEPROM data.

3. Remove Top Cover.

(3) Referring to steps (3) ~ (5) of Section 5-10-11 “Top Cover,” remove the Top Cover.

4. Remove OPT Unit.

(4) - Remove the CCD cable. 

Note: Pinching the root of connector of the CCD board to support, pull out the CCD cable straight.

- Remove the screw A (circle below) on the OPT Hold Plate, and then remove the OPT Hold Plate. 

- Lift up the OPT Unit  to remove.

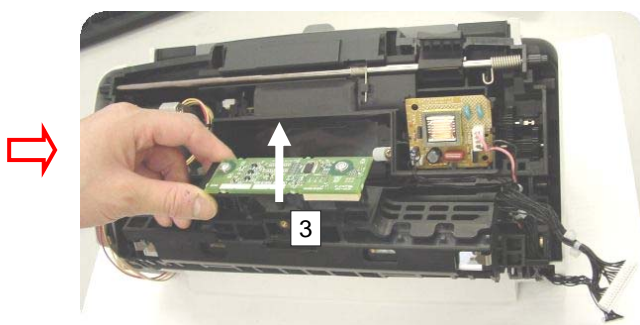
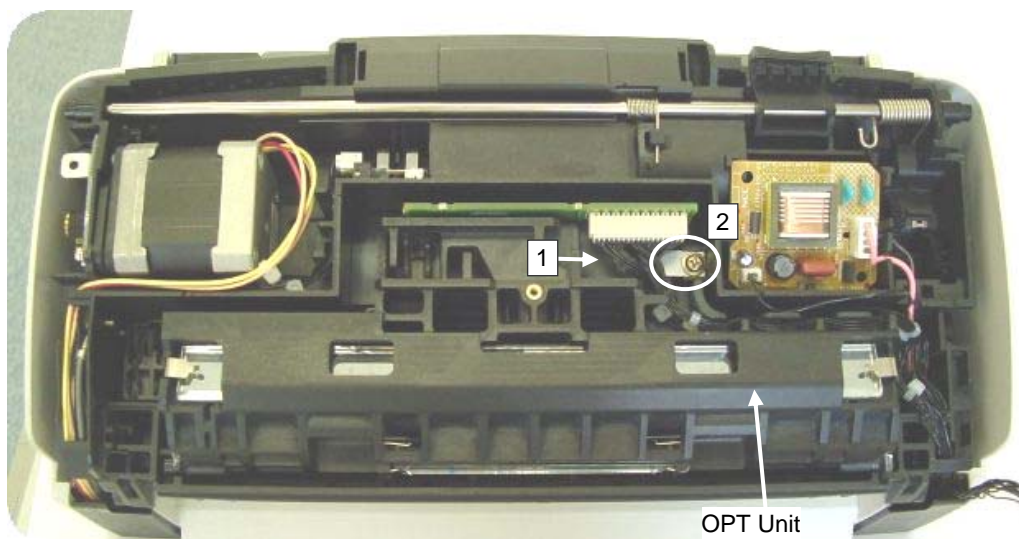

Rev.	DATE	DESIGN	CHECK	APPR.	DESCRIPTION	TITLE	fi-6140/fi-6240/fi-6130/fi-6230/fi-614PR Maintenance Manual	
08	July 27, 09	K.Okada	A.Miyoshi	I.Fujioka	Refer to Revision Record on page 2.	DRAW No.	P1PA03540-B0XX/6	CUST.
07	Nov.12, 08	K.Okada	T.Anzai	I.Fujioka	Refer to Revision Record on page 2.			
06	Mar.10, 08	K.Okada	T.Anzai	I.Fujioka	Refer to Revision Record on page 2.			
Design	July 27, 2007	K.Okada	CHECK	K.Okada	APPR.	T.Anzai	PFU LIMITED	Page 112 / 257

<Installation>

Follow the removing procedure in reverse.

Blow out the dust inside of the Glass and the OPT Unit with air before installation.

Wire the OPT Unit cable as shown below.

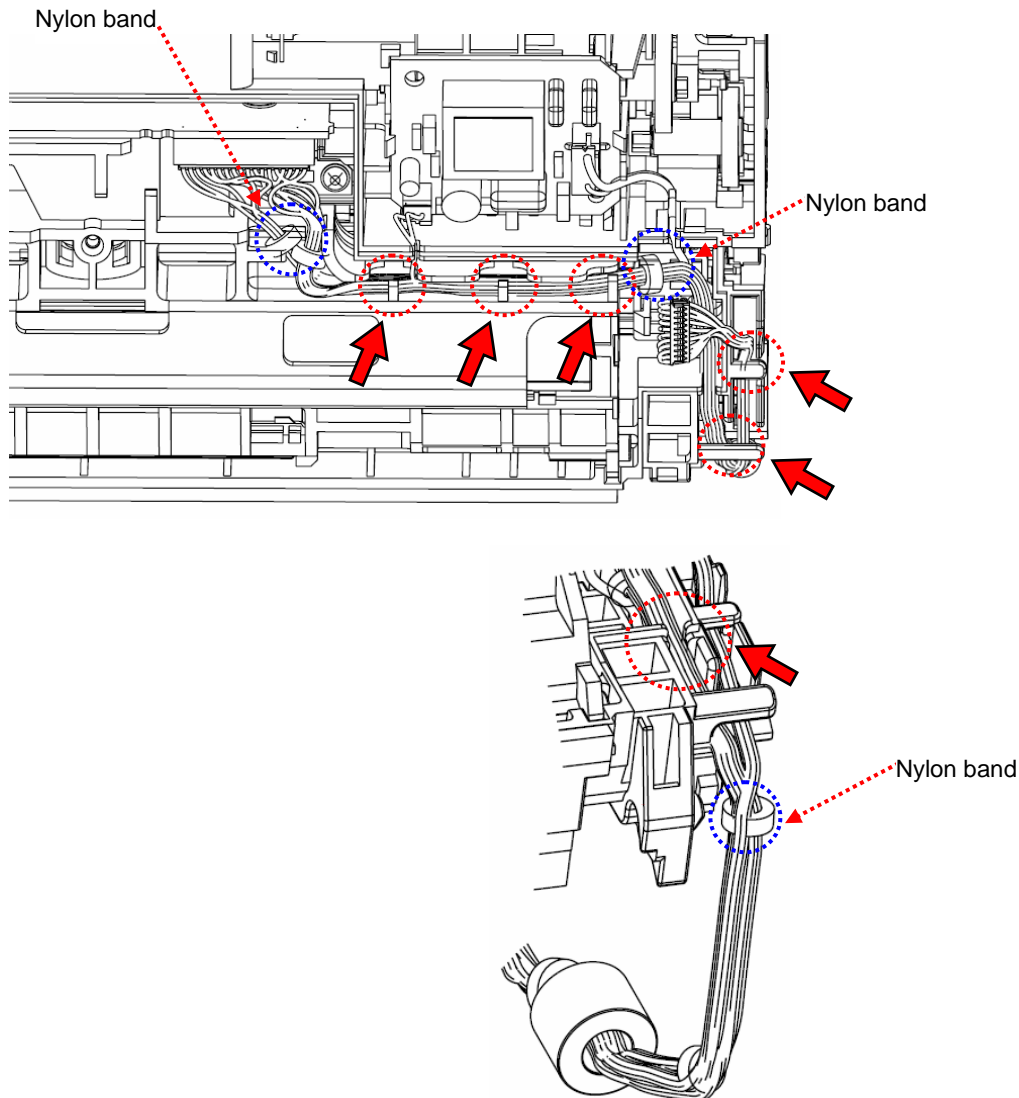

Note: Face the convex side down when installing the OPT Hold Plate.

Note: Perform the following adjustments after replacing the parts.

- Referring to Section 6-1-3 "Maintenance Mode #2," adjust the magnification.
- Referring to Section 6-1-4 "Maintenance Mode #3," adjust the offset.
- Referring to Section 6-1-5 "Maintenance Mode #4," adjust the white level.

						TITLE	fi-6140/fi-6240/fi-6130/fi-6230/fi-614PR Maintenance Manual		
08	July 27, 09	K.Okada	A.Miyoshi	I.Fujioka	Refer to Revision Record on page 2.	DRAW	No.	P1PA03540-B0XX/6	CUST.
07	Nov.12, 08	K.Okada	T.Anzai	I.Fujioka	Refer to Revision Record on page 2.				
06	Mar.10, 08	K.Okada	T.Anzai	I.Fujioka	Refer to Revision Record on page 2.				
Rev.	DATE	DESIGN	CHECK	APPR.	DESCRIPTION	PFU LIMITED		Page	113 / 257
Design	July 27, 2007	K.Okada	CHECK	K.Okada		APPR.	T.Anzai		

5-10-5 Inverter (for backside scanning)

 NOTICE

Refer to Section 3-3 for the part number of the replacement part.

<Removal>

1. Remove Chuter Unit.

(1) Referring to Section 5-8-1 “Chuter Unit (ADF Paper Chute),” remove the Chuter Unit.

2. Remove Panel PCA cable.

(2) Referring to steps of Section 5-10-9 “Panel PCA,” disconnect the Panel PCA cable.

Note: There is no need to save EEPROM data.

3. Remove Top Cover.

(3) Referring to steps (3) ~ (5) of Section 5-10-11 “Top Cover,” remove the Top Cover.

4. Remove Inverter.

(4) - Remove two Inverter cables (circles below).

- Unlatch two claws (squares below) at both sides of the Inverter to remove the Inverter.

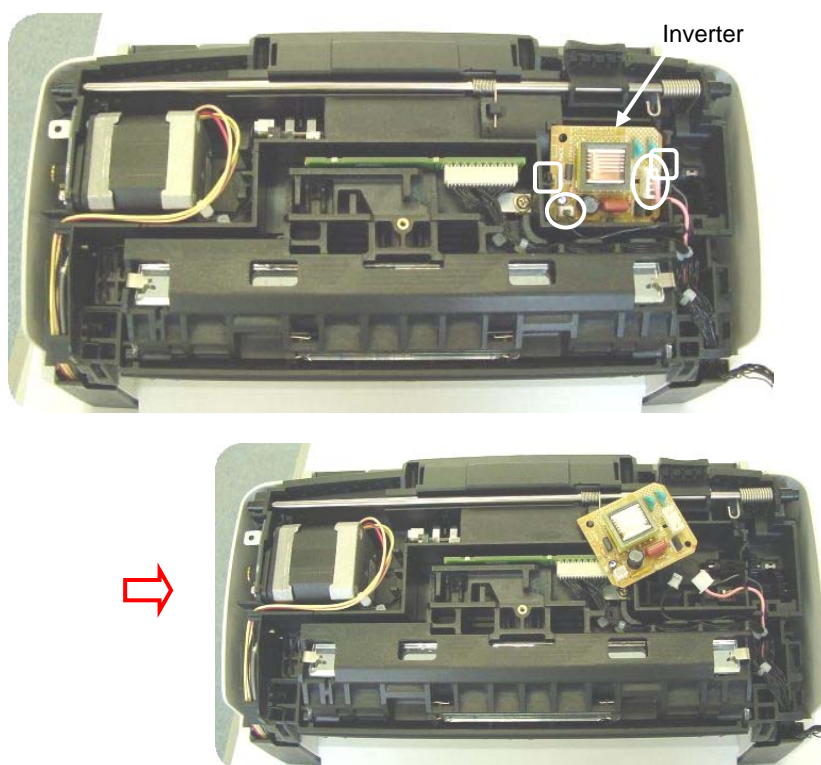

Rev.	DATE	DESIGN	CHECK	APPR.	DESCRIPTION	PFU LIMITED		
08	July 27, 09	K.Okada	A.Miyoshi	I.Fujioka	Refer to Revision Record on page 2.	TITLE	fi-6140/fi-6240/fi-6130/fi-6230/fi-614PR Maintenance Manual	
07	Nov.12, 08	K.Okada	T.Anzai	I.Fujioka	Refer to Revision Record on page 2.	DRAW No.	P1PA03540-B0XX/6	CUST.
06	Mar.10, 08	K.Okada	T.Anzai	I.Fujioka	Refer to Revision Record on page 2.			
Design	July 27, 2007	K.Okada	CHECK	K.Okada		APPR.	T.Anzai	Page 114 / 257

<Installation>

Follow the removing procedure in reverse.

Note: Make sure that the Inverter is placed under the lower hook (circle below) and the claws (squares below) at both sides of the Inverter are securely latched.

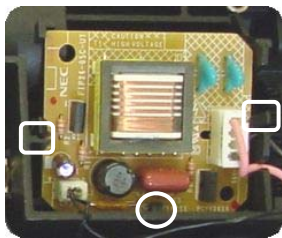

Wire the lamp cable as shown below.

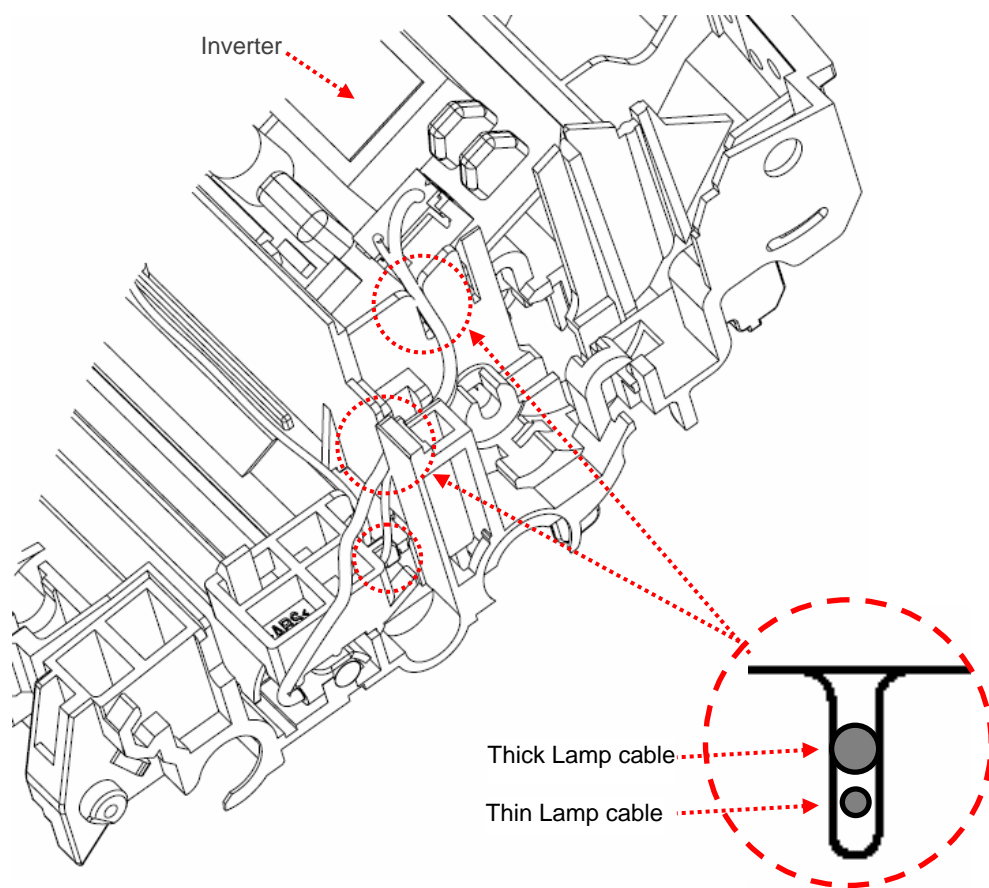

Note: Perform the following adjustments after replacing the parts.

- Referring to Section 6-1-3 “Maintenance Mode #2,” adjust the magnification.
- Referring to Section 6-1-4 “Maintenance Mode #3,” adjust the offset.
- Referring to Section 6-1-5 “Maintenance Mode #4,” adjust the white level.

						TITLE	fi-6140/fi-6240/fi-6130/fi-6230/fi-614PR Maintenance Manual		
08	July 27, 09	K.Okada	A.Miyoshi	I.Fujioka	Refer to Revision Record on page 2.	DRAW	P1PA03540-B0XX/6	CUST.	
07	Nov.12, 08	K.Okada	T.Anzai	I.Fujioka	Refer to Revision Record on page 2.	No.			
06	Mar.10, 08	K.Okada	T.Anzai	I.Fujioka	Refer to Revision Record on page 2.				
Rev.	DATE	DESIGN	CHECK	APPR.	DESCRIPTION	PFU LIMITED		Page	115 / 257
Design	July 27, 2007	K.Okada	CHECK	K.Okada		APPR.	T.Anzai		

5-10-6 Lamp (for backside scanning)

NOTICE

Refer to Section 3-4 for the part number of the replacement part.

<Removal>

1. Remove Chuter Unit.

(1) Referring to Section 5-8-1 "Chuter Unit (ADF Paper Chute)," remove the Chuter Unit.

2. Remove Panel PCA cable.

(2) Referring to steps of Section 5-10-9 "Panel PCA," disconnect the Panel PCA cable.

Note: There is no need to save EEPROM data.

3. Remove Top Cover.

(3) Referring to steps (3) ~ (5) of Section 5-10-11 "Top Cover," remove the Top Cover.

4. Remove OPT Unit.

(4) Referring to step (4) of Section 5-10-4 "OPT Unit (for backside scanning)," remove the OPT Unit.

5. Remove Lamp.

(5) - Remove the thin Lamp cable from six BK Cover hooks (circles below).

- Disconnect the Lamp cable from the Inverter (square below).

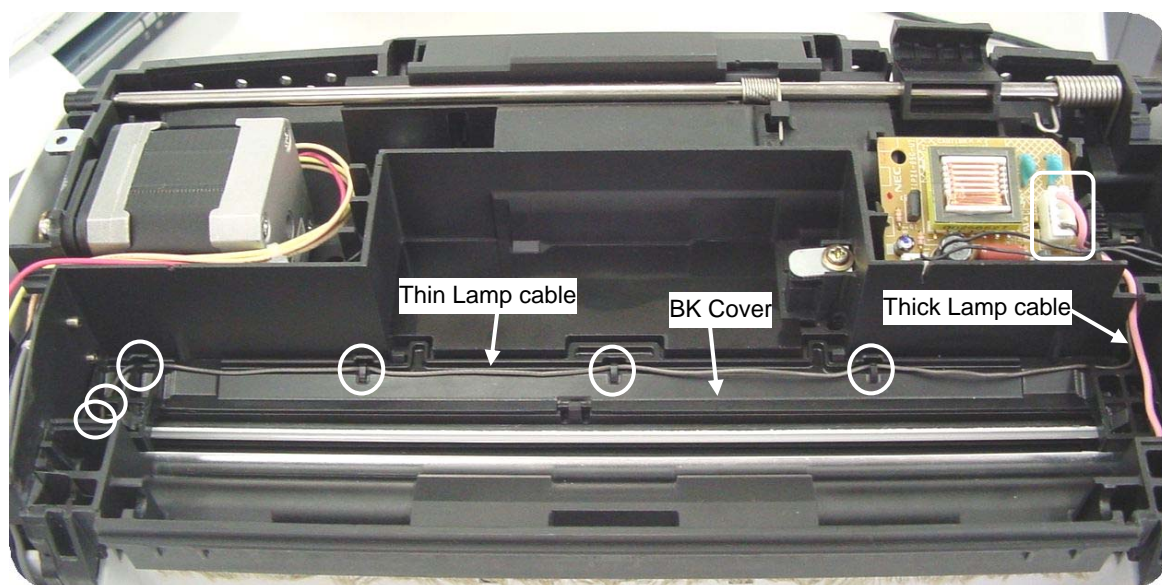

Rev.	DATE	DESIGN	CHECK	APPR.	DESCRIPTION	TITLE	fi-6140/fi-6240/fi-6130/fi-6230/fi-614PR Maintenance Manual		
08	July 27, 09	K.Okada	A.Miyoshi	I.Fujioka	Refer to Revision Record on page 2.	DRAW No.	P1PA03540-B0XX/6	CUST.	
07	Nov.12, 08	K.Okada	T.Anzai	I.Fujioka	Refer to Revision Record on page 2.				
06	Mar.10, 08	K.Okada	T.Anzai	I.Fujioka	Refer to Revision Record on page 2.				
Design	July 27, 2007	K.Okada	CHECK	K.Okada	APPR.	T.Anzai	PFU LIMITED	Page	116 / 257

(6) Unlatch seven hooks (circles below) on the BK Cover, and then remove the BK Cover in the order of 1 → 2.

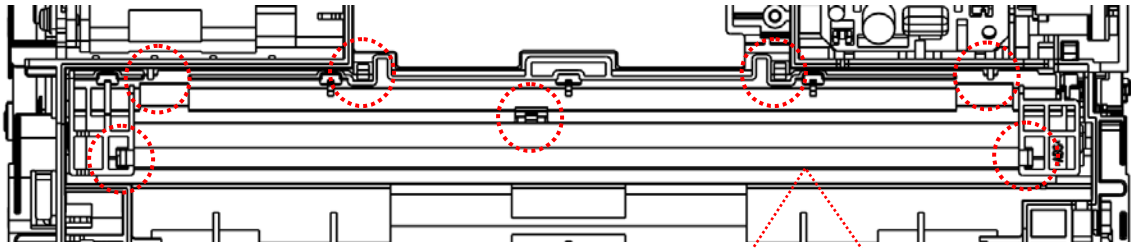

						TITLE	fi-6140/fi-6240/fi-6130/fi-6230/fi-614PR Maintenance Manual		
08	July 27, 09	K.Okada	A.Miyoshi	I.Fujioka	Refer to Revision Record on page 2.	DRAW No.	P1PA03540-B0XX/6	CUST.	
07	Nov.12, 08	K.Okada	T.Anzai	I.Fujioka	Refer to Revision Record on page 2.				
06	Mar.10, 08	K.Okada	T.Anzai	I.Fujioka	Refer to Revision Record on page 2.				
Rev.	DATE	DESIGN	CHECK	APPR.	DESCRIPTION	PFU LIMITED		Page	117 / 257
Design	July 27, 2007	K.Okada	CHECK	K.Okada		APPR.	T.Anzai		

- (7) - Lift up the reflector to remove. ①
- Remove the Lamp from the thick Lamp cable side at first. ②

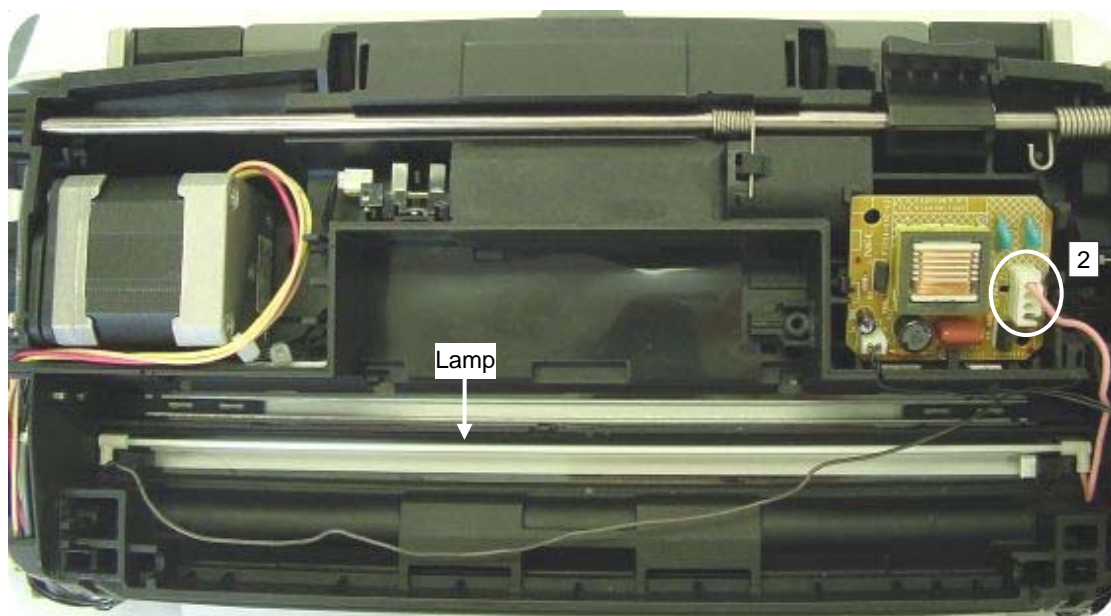
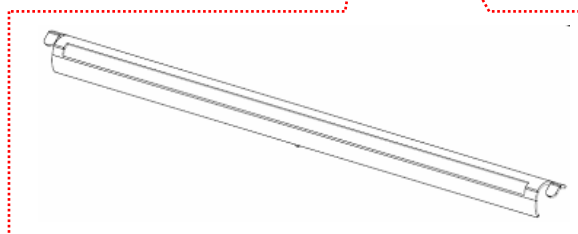
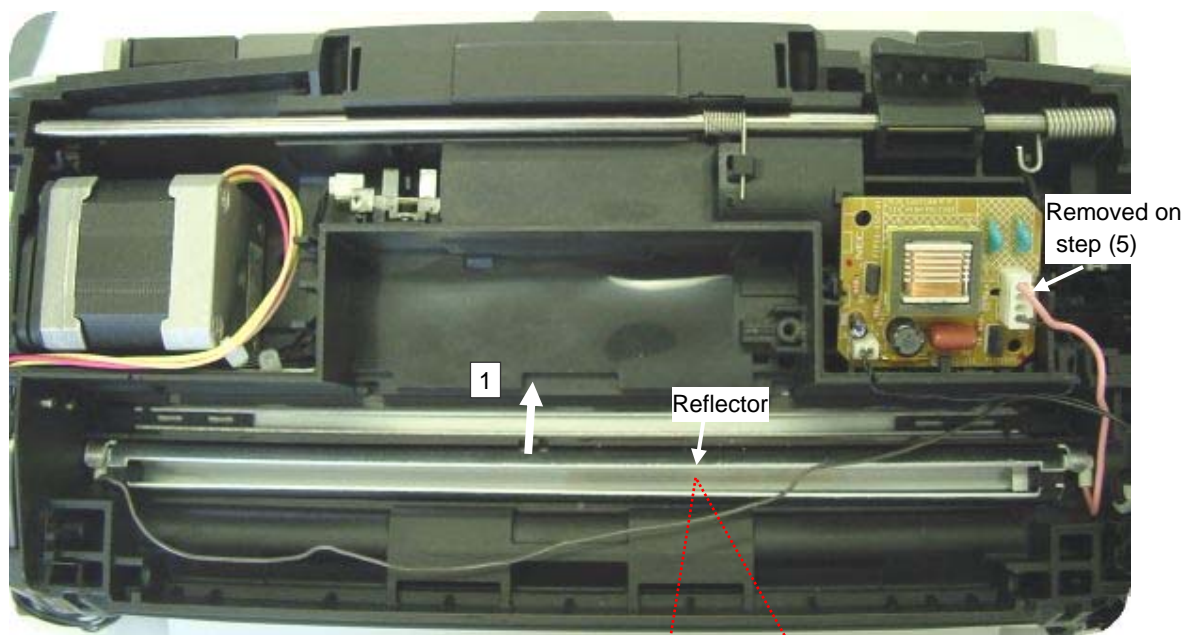

						TITLE	fi-6140/fi-6240/fi-6130/fi-6230/fi-614PR Maintenance Manual		
08	July 27, 09	K.Okada	A.Miyoshi	I.Fujioka	Refer to Revision Record on page 2.	DRAW No.	P1PA03540-B0XX/6		CUST.
07	Nov.12, 08	K.Okada	T.Anzai	I.Fujioka	Refer to Revision Record on page 2.				
06	Mar.10, 08	K.Okada	T.Anzai	I.Fujioka	Refer to Revision Record on page 2.				
Rev.	DATE	DESIGN	CHECK	APPR.	DESCRIPTION	PFU LIMITED		Page	118 / 257
Design	July 27, 2007	K.Okada	CHECK	K.Okada		APPR.	T.Anzai		

<Installation>

Follow the removing procedure in reverse.

Blow out the dust inside of the Glass and the OPT Unit with air before installation.

- (1) Place the Lamp on the groove of the frame.

Note: Install the Lamp at the thin Lamp cable side at first.

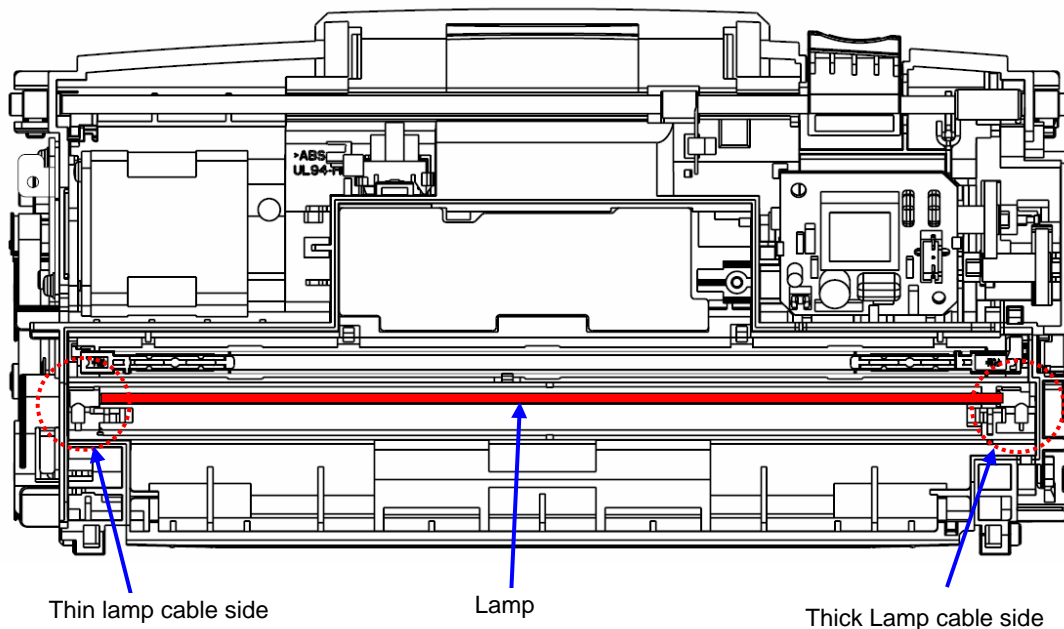

- (2) Install the reflector to the frame.

Note: Make sure that the protrusions of the reflector are inserted into the holes of the frame.

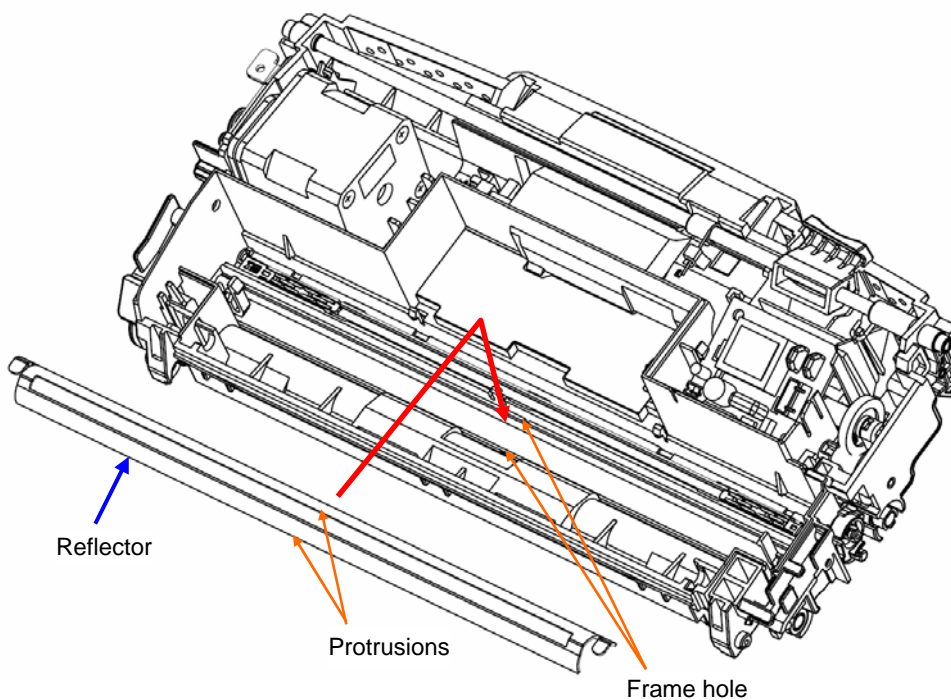

						TITLE	fi-6140/fi-6240/fi-6130/fi-6230/fi-614PR Maintenance Manual		
08	July 27, 09	K.Okada	A.Miyoshi	I.Fujioka	Refer to Revision Record on page 2.	DRAW	P1PA03540-B0XX/6	CUST.	
07	Nov.12, 08	K.Okada	T.Anzai	I.Fujioka	Refer to Revision Record on page 2.	No.			
06	Mar.10, 08	K.Okada	T.Anzai	I.Fujioka	Refer to Revision Record on page 2.				
Rev.	DATE	DESIGN	CHECK	APPR.	DESCRIPTION	PFU LIMITED		Page	119 / 257
Design	July 27, 2007	K.Okada	CHECK	K.Okada		APPR.	T.Anzai		

(3) Install the BK Cover to the frame.

Note: Make sure that seven claws of the frame are secured.

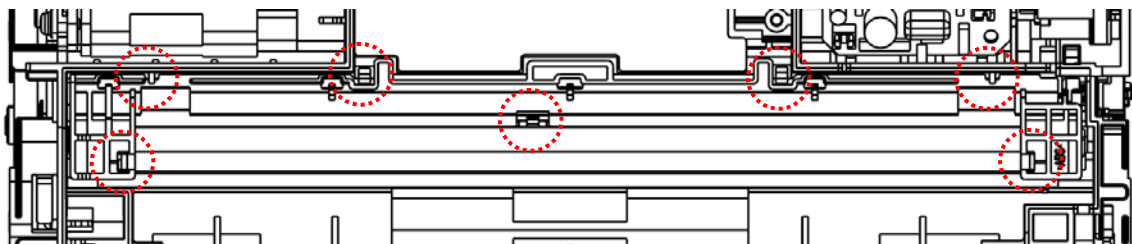
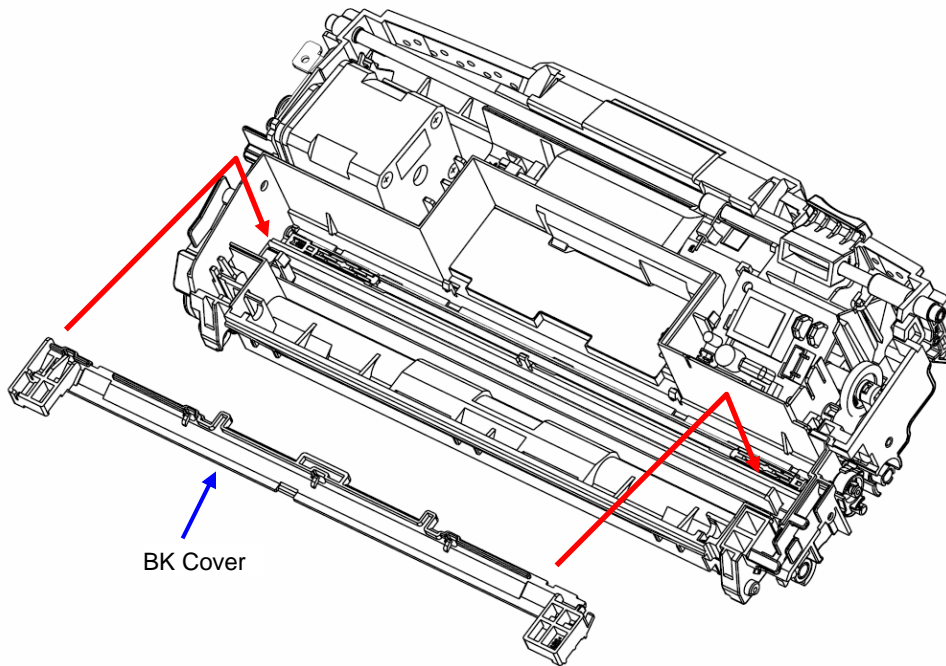

						TITLE	fi-6140/fi-6240/fi-6130/fi-6230/fi-614PR Maintenance Manual		
08	July 27, 09	K.Okada	A.Miyoshi	I.Fujioka	Refer to Revision Record on page 2.	DRAW	P1PA03540-B0XX/6	CUST.	
07	Nov.12, 08	K.Okada	T.Anzai	I.Fujioka	Refer to Revision Record on page 2.	No.			
06	Mar.10, 08	K.Okada	T.Anzai	I.Fujioka	Refer to Revision Record on page 2.				
Rev.	DATE	DESIGN	CHECK	APPR.	DESCRIPTION	PFU LIMITED		Page	120 / 257
Design	July 27, 2007	K.Okada	CHECK	K.Okada		APPR.	T.Anzai		

- (4) - Hook the thin Lamp cable onto six BK Cover hooks (circles below).
- Connect the Lamp cable to the Inverter.

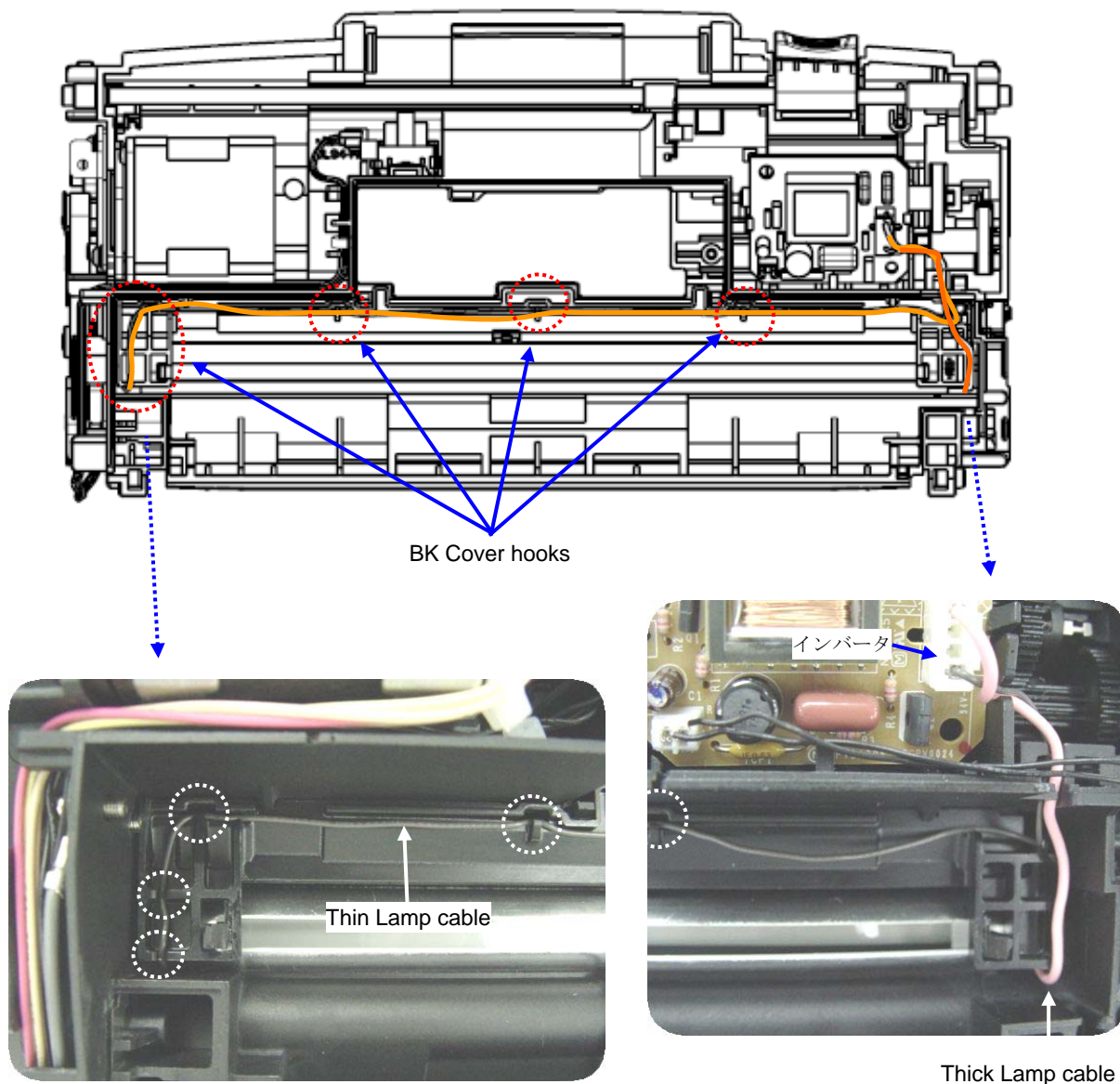

						TITLE	fi-6140/fi-6240/fi-6130/fi-6230/fi-614PR Maintenance Manual		
08	July 27, 09	K.Okada	A.Miyoshi	I.Fujioka	Refer to Revision Record on page 2.	DRAW	P1PA03540-B0XX/6	CUST.	
07	Nov.12, 08	K.Okada	T.Anzai	I.Fujioka	Refer to Revision Record on page 2.	No.			
06	Mar.10, 08	K.Okada	T.Anzai	I.Fujioka	Refer to Revision Record on page 2.				
Rev.	DATE	DESIGN	CHECK	APPR.	DESCRIPTION	PFU LIMITED		Page	121 / 257
Design	July 27, 2007	K.Okada	CHECK	K.Okada		APPR.	T.Anzai		

Wire the Lamp cable as shown below.

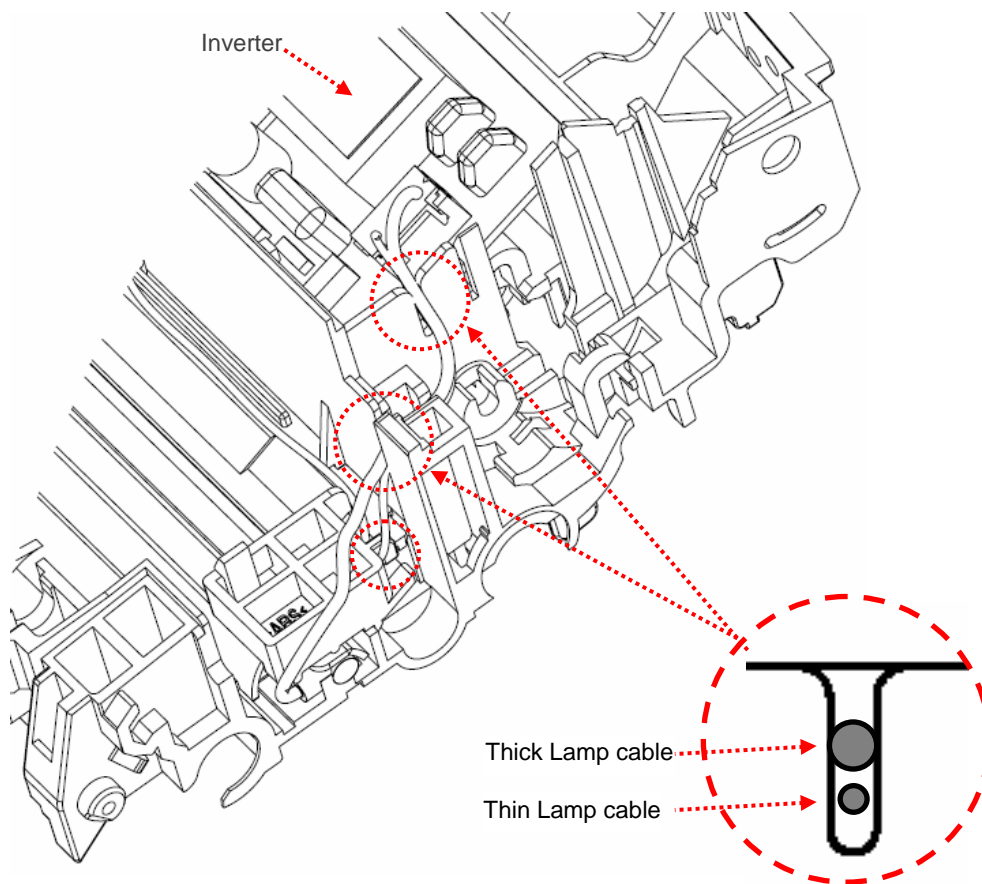

Note: Perform the following adjustments after replacing the parts.

- Referring to Section 6-1-3 “Maintenance Mode #2,” adjust the magnification.
- Referring to Section 6-1-4 “Maintenance Mode #3,” adjust the offset.
- Referring to Section 6-1-5 “Maintenance Mode #4,” adjust the white level.

						TITLE	fi-6140/fi-6240/fi-6130/fi-6230/fi-614PR Maintenance Manual		
08	July 27, 09	K.Okada	A.Miyoshi	I.Fujioka	Refer to Revision Record on page 2.	DRAW	P1PA03540-B0XX/6	CUST.	
07	Nov.12, 08	K.Okada	T.Anzai	I.Fujioka	Refer to Revision Record on page 2.	No.			
06	Mar.10, 08	K.Okada	T.Anzai	I.Fujioka	Refer to Revision Record on page 2.				
Rev.	DATE	DESIGN	CHECK	APPR.	DESCRIPTION	PFU LIMITED		Page	122 / 257
Design	July 27, 2007	K.Okada	CHECK	K.Okada		APPR.	T.Anzai		

5-10-7 US Sensor RV (Multifeed detection)

NOTICE

- Refer to Section 3-19 for the part number of the replacement part.
- Refer to Appendix for the specification of the screws.

<Removal>

1. Remove Chuter Unit.

(1) Referring to Section 5-8-1 “Chuter Unit (ADF Paper Chute),” remove the Chuter Unit.

2. Remove US Sensor RV

(2) - Open the Upper Unit.

- Remove two screws A (circles below) on the Feed roller cover, and then remove the cover.

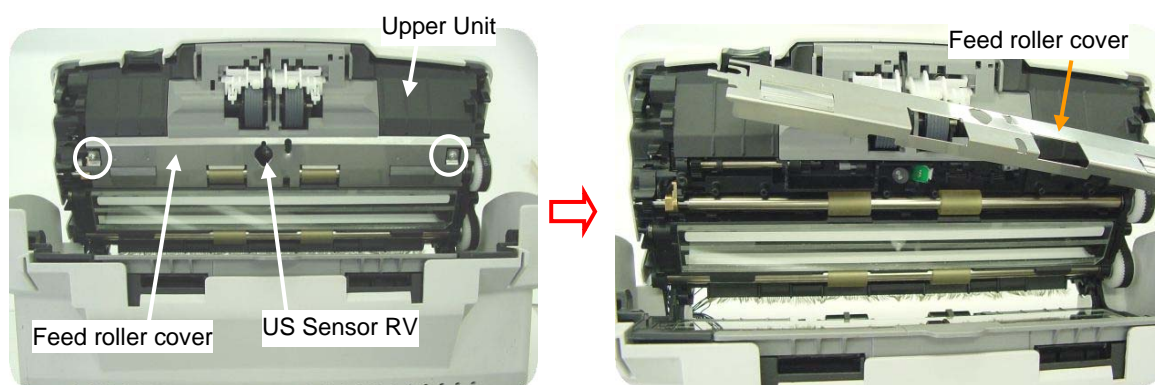

(3) - Unlatch the claw (square below) of the US Sensor RV to remove the US Sensor RV.

- Remove US Sensor RV cable (circle below).

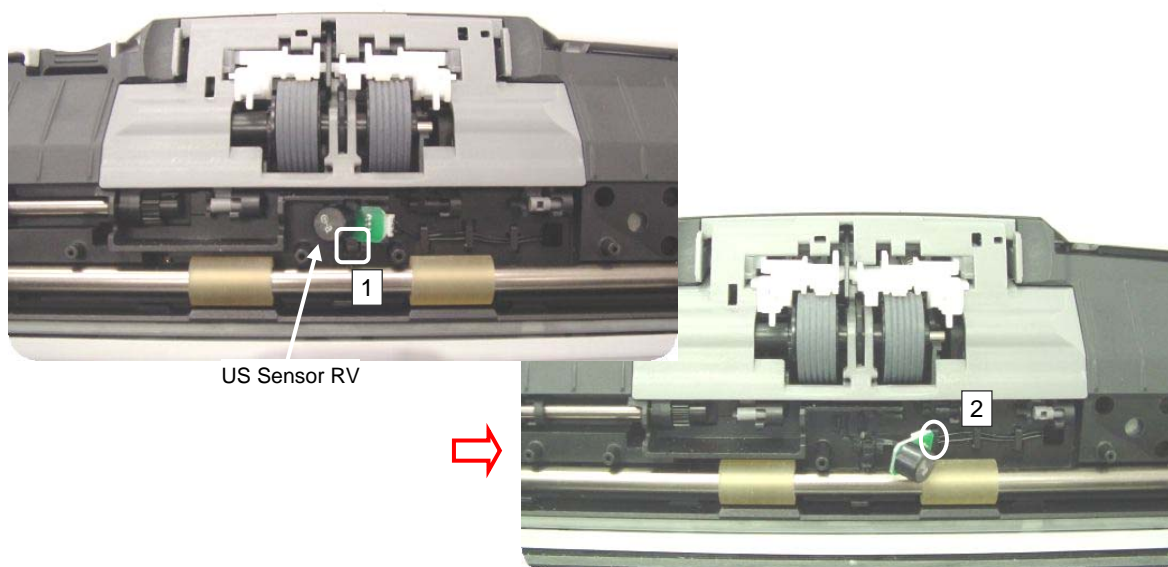

<Installation>

Follow the removing procedure in reverse.

Note: Referring to Section 6-1-2 “Maintenance Mode #1,” check the sensor operation.

Rev.	DATE	DESIGN	CHECK	APPR.	DESCRIPTION	TITLE	fi-6140/fi-6240/fi-6130/fi-6230/fi-614PR Maintenance Manual	
08	July 27, 09	K.Okada	A.Miyoshi	I.Fujioka	Refer to Revision Record on page 2.	DRAW No.	P1PA03540-B0XX/6	CUST.
07	Nov.12, 08	K.Okada	T.Anzai	I.Fujioka	Refer to Revision Record on page 2.			
06	Mar.10, 08	K.Okada	T.Anzai	I.Fujioka	Refer to Revision Record on page 2.			
Design	July 27, 2007	K.Okada	CHECK	K.Okada	APPR.	T.Anzai	PFU LIMITED	Page 123 / 257

5-10-8 Sensor EMP (Paper empty detection)

NOTICE

Refer to Section 3-20 for the part number of the replacement part.

<Removal>

1. Remove Chuter Unit.

(1) Referring to Section 5-8-1 “Chuter Unit (ADF Paper Chute),” remove the Chuter Unit.

2. Remove Panel PCA cable.

(2) Referring to steps of Section 5-10-9 “Panel PCA,” disconnect the Panel PCA cable.

Note: There is no need to save EEPROM data.

3. Remove Top Cover.

(3) Referring to steps (3) ~ (5) of Section 5-10-11 “Top Cover,” remove the Top Cover.

4. Remove Sensor EMP

(4) - Unlatch two claws (squares below) from the right side of the Sensor EMP at first, and then remove the Sensor EMP.
- Remove the Sensor EMP cable (circle below).

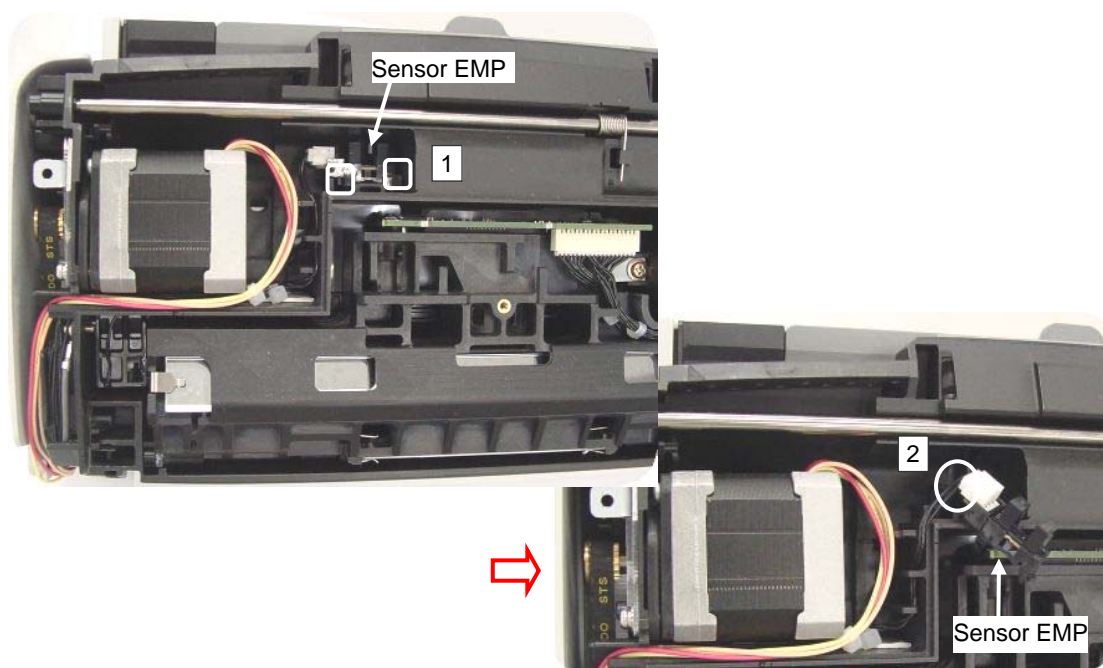

<Installation>

Follow the removing procedure in reverse.

Note: Make sure that the claws at both sides of the Sensor EMP are securely latched.

After replacing the part, perform the sensor test by referring to Section 6-1-2 “Maintenance Mode #1.”

Rev.	DATE	DESIGN	CHECK	APPR.	DESCRIPTION	TITLE	fi-6140/fi-6240/fi-6130/fi-6230/fi-614PR Maintenance Manual			
08	July 27, 09	K.Okada	A.Miyoshi	I.Fujioka	Refer to Revision Record on page 2.	DRAW No.	P1PA03540-B0XX/6	CUST.		
07	Nov.12, 08	K.Okada	T.Anzai	I.Fujioka	Refer to Revision Record on page 2.					
06	Mar.10, 08	K.Okada	T.Anzai	I.Fujioka	Refer to Revision Record on page 2.					
Design	July 27, 2007	K.Okada	CHECK	K.Okada		APPR.	T.Anzai	PFU LIMITED	Page	124 / 257

5-10-9 Panel PCA

NOTICE

Refer to Section 3-21 for the part number of the replacement part.

<Removal>

Save EEPROM data.

Referring to Section 6-2 “Saving EEPROM data,” save the EEPROM data.

1. Remove Panel PCA.

(1) - Open the Upper Unit.

- From inside of the Upper Unit, push the claw (circle below) of the Operator Panel with a flat-blade screwdriver downward of the scanner to remove. **1**
- Remove the Operator Panel in the order of **2** → **3**.

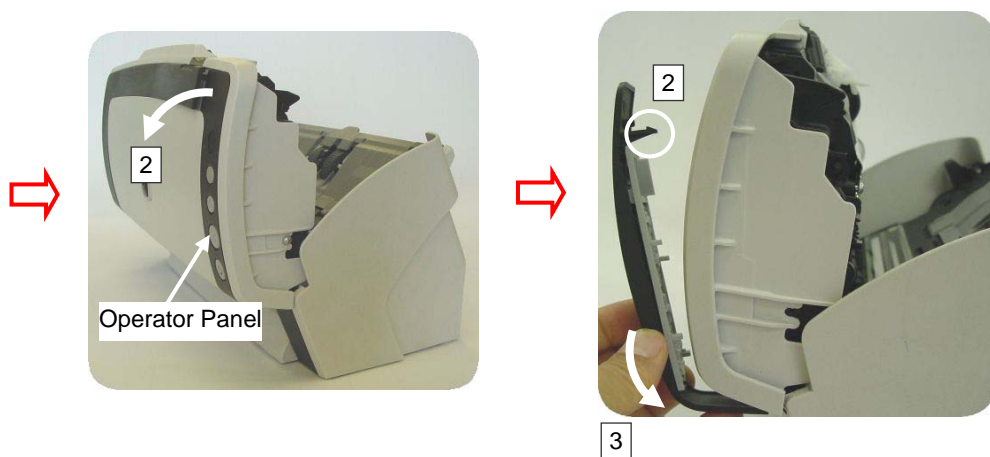
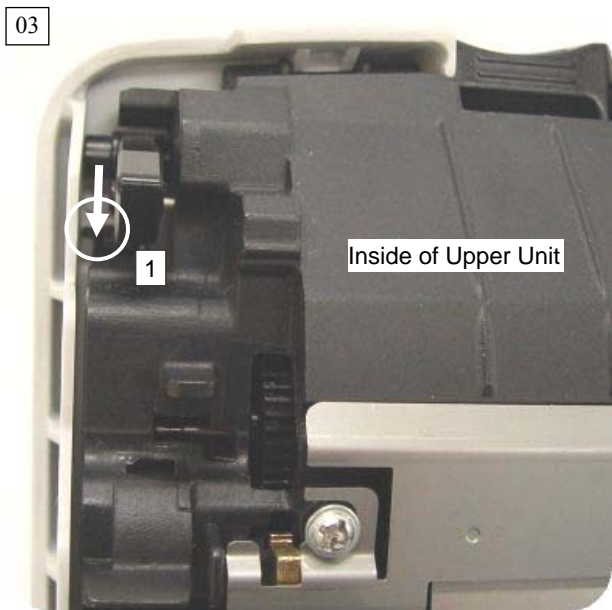

						TITLE	fi-6140/fi-6240/fi-6130/fi-6230/fi-614PR Maintenance Manual		
08	July 27, 09	K.Okada	A.Miyoshi	I.Fujioka	Refer to Revision Record on page 2.	DRAW	P1PA03540-B0XX/6	CUST.	
07	Nov.12, 08	K.Okada	T.Anzai	I.Fujioka	Refer to Revision Record on page 2.	No.			
06	Mar.10, 08	K.Okada	T.Anzai	I.Fujioka	Refer to Revision Record on page 2.				
Rev.	DATE	DESIGN	CHECK	APPR.	DESCRIPTION	PFU LIMITED		Page	125 / 257
Design	July 27, 2007	K.Okada	CHECK	K.Okada		APPR.	T.Anzai		

(2) Remove the Panel PCA, and then disconnect the Panel PCA cable (circle below).

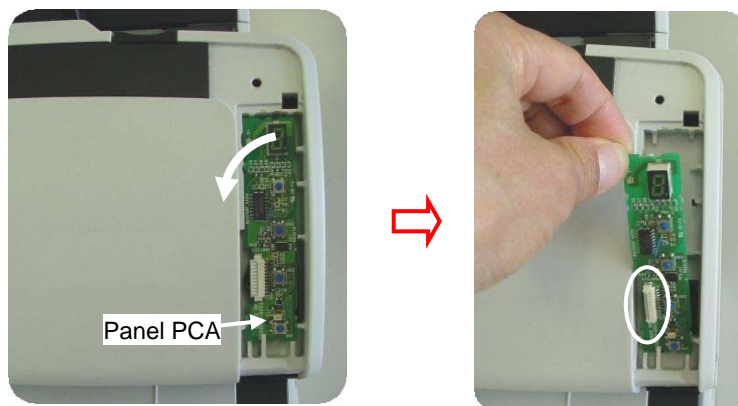

<Installation>

Follow the removing procedure in reverse.

Note: Referring to Section 6-1-8 “EEPROM data restore,” restore the EEPROM data.

						TITLE	fi-6140/fi-6240/fi-6130/fi-6230/fi-614PR Maintenance Manual		
08	July 27, 09	K.Okada	A.Miyoshi	I.Fujioka	Refer to Revision Record on page 2.	DRAW No.	P1PA03540-B0XX/6	CUST.	
07	Nov.12, 08	K.Okada	T.Anzai	I.Fujioka	Refer to Revision Record on page 2.				
06	Mar.10, 08	K.Okada	T.Anzai	I.Fujioka	Refer to Revision Record on page 2.				
Rev.	DATE	DESIGN	CHECK	APPR.	DESCRIPTION	PFU LIMITED		Page	126 / 257
Design	July 27, 2007	K.Okada	CHECK	K.Okada		APPR.	T.Anzai		

5-10-10 BR Shaft ASSY

NOTICE

Refer to Section 3-22 for the part number of the replacement part.

<Removal>

I. Remove BR Shaft ASSY.

(1) - Open the Upper Unit.

- Grab both sides of the Brake roller cover, and press to the direction of the arrow to open.
- Lift up the right side of the Brake roller and remove the right shaft. Then pull the left shaft out of its hole to remove it.

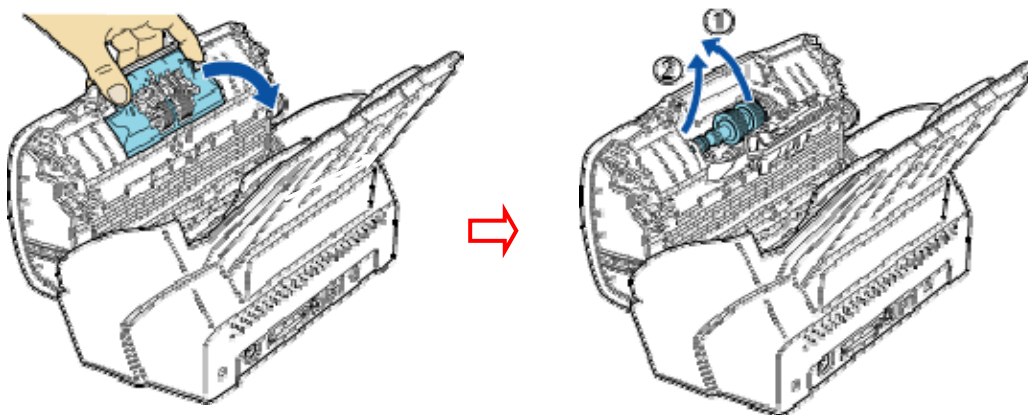

(2) Remove the Brake roller from the RB Shaft ASSY.

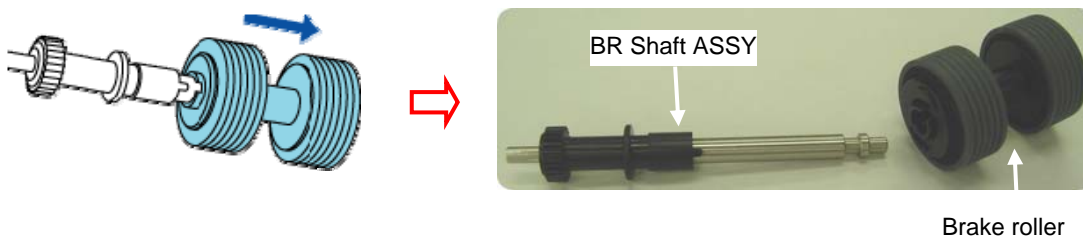

<Installation>

Follow the removing procedure in reverse.

						TITLE	fi-6140/fi-6240/fi-6130/fi-6230/fi-614PR Maintenance Manual		
08	July 27, 09	K.Okada	A.Miyoshi	I.Fujioka	Refer to Revision Record on page 2.	DRAW No.	P1PA03540-B0XX/6		CUST.
07	Nov.12, 08	K.Okada	T.Anzai	I.Fujioka	Refer to Revision Record on page 2.				
06	Mar.10, 08	K.Okada	T.Anzai	I.Fujioka	Refer to Revision Record on page 2.				
Rev.	DATE	DESIGN	CHECK	APPR.	DESCRIPTION	PFU LIMITED		Page	127 / 257
Design	July 27, 2007	K.Okada	CHECK	K.Okada		APPR.	T.Anzai		

5-10-11 Top Cover

NOTICE

- Top Cover is not a Maintenance Part.
- Refer to Appendix for the specification of the screws.

<Removal>

1. Remove Chuter Unit.

(1) Referring to Section 5-8-1 “Chuter Unit (ADF Paper Chute),” remove the Chuter Unit.

2. Remove Panel PCA cable.

(2) Referring to steps of Section 5-10-9 “Panel PCA,” disconnect the Panel PCA cable.

Note: There is no need to save EEPROM data.

3. Remove Top Cover.

(3) - Open the Upper Unit.

- Remove two screws A (circles below) at both sides of the Top Cover.

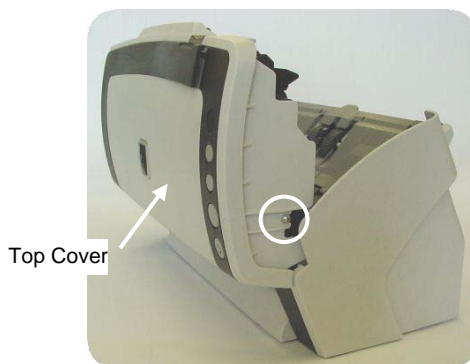

(4) - Close the Upper Unit.

- Unhook three hooks at the lower position of the Top Cover.

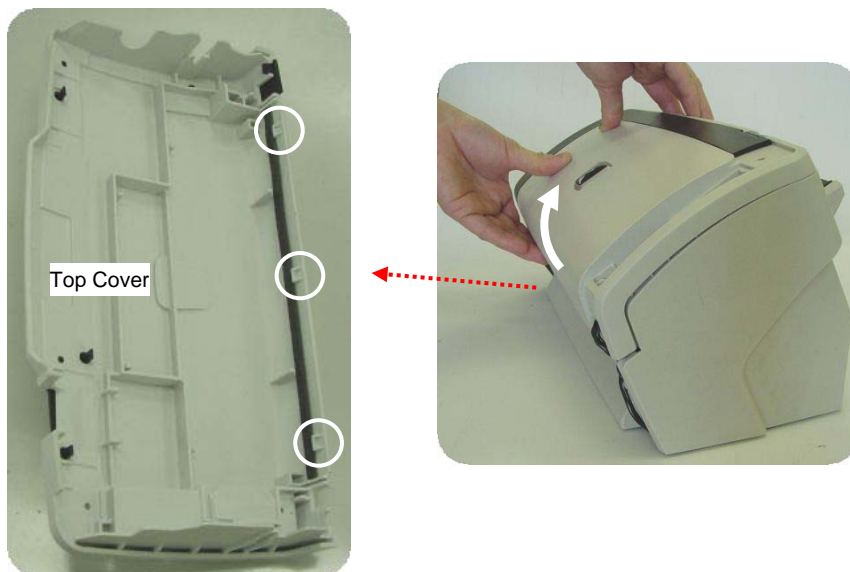

						TITLE	fi-6140/fi-6240/fi-6130/fi-6230/fi-614PR Maintenance Manual		
08	July 27, 09	K.Okada	A.Miyoshi	I.Fujioka	Refer to Revision Record on page 2.	DRAW	P1PA03540-B0XX/6	CUST.	
07	Nov.12, 08	K.Okada	T.Anzai	I.Fujioka	Refer to Revision Record on page 2.	No.			
06	Mar.10, 08	K.Okada	T.Anzai	I.Fujioka	Refer to Revision Record on page 2.				
Rev.	DATE	DESIGN	CHECK	APPR.	DESCRIPTION	PFU LIMITED		Page	128 / 257
Design	July 27, 2007	K.Okada	CHECK	K.Okada		APPR.	T.Anzai		

(5) Move the Top Cover upward to remove of the Top Cover.

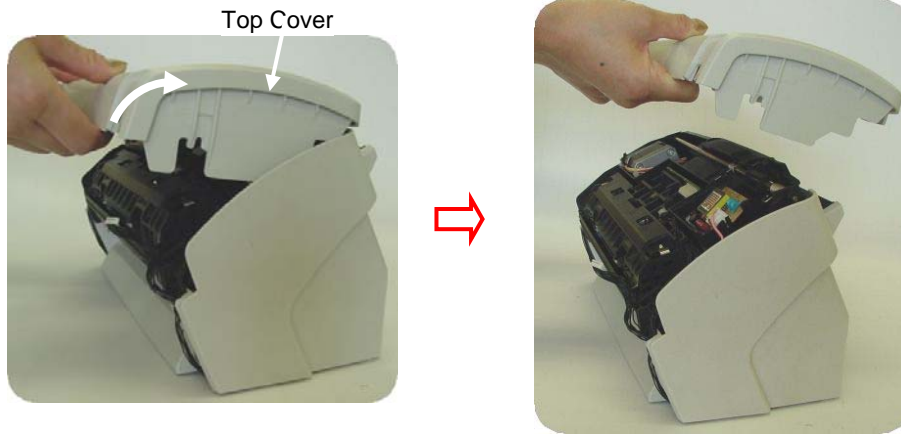

<Installation>

Follow the removing procedure in reverse.

						TITLE	fi-6140/fi-6240/fi-6130/fi-6230/fi-614PR Maintenance Manual		
08	July 27, 09	K.Okada	A.Miyoshi	I.Fujioka	Refer to Revision Record on page 2.	DRAW No.	P1PA03540-B0XX/6	CUST.	
07	Nov.12, 08	K.Okada	T.Anzai	I.Fujioka	Refer to Revision Record on page 2.				
06	Mar.10, 08	K.Okada	T.Anzai	I.Fujioka	Refer to Revision Record on page 2.				
Rev.	DATE	DESIGN	CHECK	APPR.	DESCRIPTION	PFU LIMITED		Page	129 / 257
Design	July 27, 2007	K.Okada	CHECK	K.Okada		APPR.	T.Anzai		

5-11 Control PCA

NOTICE

- Refer to Section 3-23 for the part number of the replacement part.
- Refer to Appendix for the specification of the screws.

<Removal>

Remove the imprinter (option).

fi-6140/fi-6130 with Imprinter Referring to Section 8-6-4 “Removing Imprinter”, remove the Imprinter.

Remove Flatbed.

fi-6240/fi-6230 Referring to Section 5-7 “Removing Flatbed,” remove the Flatbed.



1. Remove Chuter Unit.

(1) Referring to Section 5-8-1 “Chuter Unit (ADF Paper Chute),” remove the Chuter Unit.

2. Remove Control PCA.

(2) - Place the ADF as shown below.

The photo below is fi-6240/fi-6230. fi-6140/fi-6130 does not have a connector at the bottom of the ADF.

- Remove four screws C (circles below) at the bottom of the ADF , tilt the Control PCA to the front , and then remove the Control PCA .

- Disconnect eight cables of the Control PCA.

Pressing the Control PCA with fingers to prevent it from coming loose, pull out the cables straight upward.

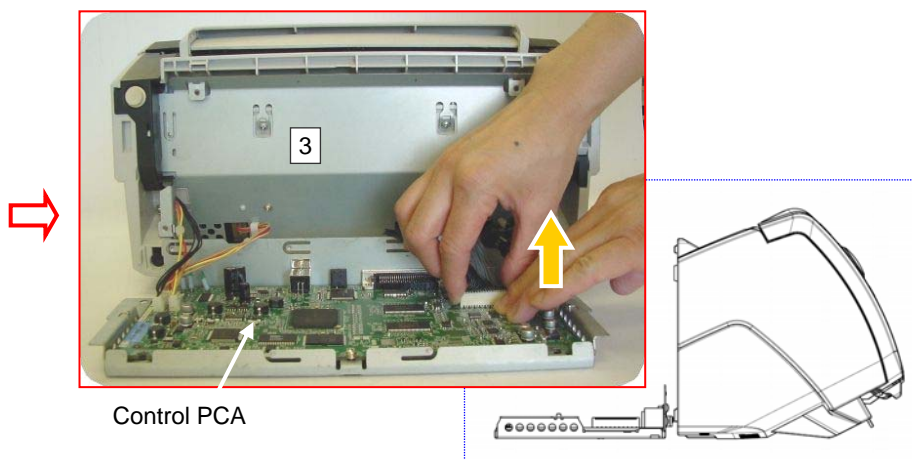
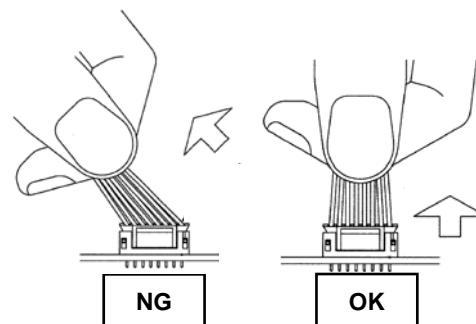
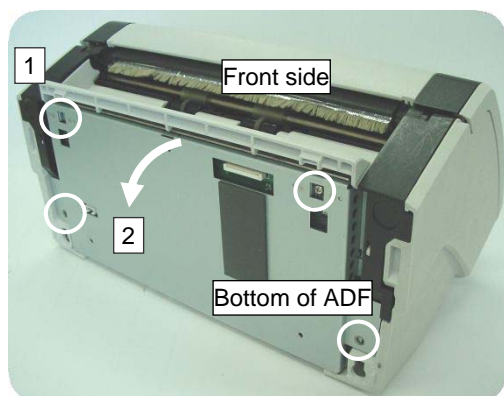

Control PCA

						TITLE	fi-6140/fi-6240/fi-6130/fi-6230/fi-614PR Maintenance Manual		
08	July 27, 09	K.Okada	A.Miyoshi	I.Fujioka	Refer to Revision Record on page 2.	DRAW	P1PA03540-B0XX/6	CUST.	
07	Nov.12, 08	K.Okada	T.Anzai	I.Fujioka	Refer to Revision Record on page 2.	No.			
06	Mar.10, 08	K.Okada	T.Anzai	I.Fujioka	Refer to Revision Record on page 2.				
Rev.	DATE	DESIGN	CHECK	APPR.	DESCRIPTION	PFU LIMITED		Page	130 / 257
Design	July 27, 2007	K.Okada	CHECK	K.Okada		APPR.	T.Anzai		

(3) Remove four screws (circles below) of the Control PCA, and then remove the bracket.

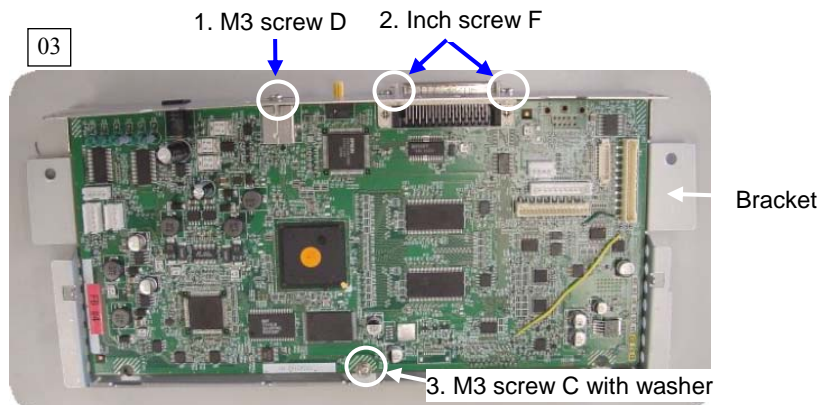

<Installation>

Follow the removing procedure in reverse.

Note: Tighten four screws of the Control PCA in the following order.

1. M3 screw D (1)
2. Inch screws F (2)
3. M3 screw C with washer (1)

Note: Before closing the PCB unit, draw the cables to the right, and check that the nylon band is located righter than the connector edge (left).

OK

Connector edge

Nylon band

Nylon band

The nylon band locates at right side of the connector edge (left).

NG

Connector edge

Nylon band

Nylon band

The nylon band locates at left side of the connector edge (left).

						TITLE	fi-6140/fi-6240/fi-6130/fi-6230/fi-614PR Maintenance Manual		
08	July 27, 09	K.Okada	A.Miyoshi	I.Fujioka	Refer to Revision Record on page 2.	DRAW	P1PA03540-B0XX/6	CUST.	
07	Nov.12, 08	K.Okada	T.Anzai	I.Fujioka	Refer to Revision Record on page 2.	No.			
06	Mar.10, 08	K.Okada	T.Anzai	I.Fujioka	Refer to Revision Record on page 2.				
Rev.	DATE	DESIGN	CHECK	APPR.	DESCRIPTION	PFU LIMITED		Page	131 / 257
Design	July 27, 2007	K.Okada	CHECK	K.Okada		APPR.	T.Anzai		

Note: Make sure that two protrusions (solid squares below) of the bracket are inserted into the holes (dotted squares below) at the bottom of the ADF.



03



						TITLE	fi-6140/fi-6240/fi-6130/fi-6230/fi-614PR Maintenance Manual		
08	July 27, 09	K.Okada	A.Miyoshi	I.Fujioka	Refer to Revision Record on page 2.	DRAW	No.	P1PA03540-B0XX/6	CUST.
07	Nov.12, 08	K.Okada	T.Anzai	I.Fujioka	Refer to Revision Record on page 2.				
06	Mar.10, 08	K.Okada	T.Anzai	I.Fujioka	Refer to Revision Record on page 2.				
Rev.	DATE	DESIGN	CHECK	APPR.	DESCRIPTION	PFU LIMITED		Page	132 / 257
Design	July 27, 2007	K.Okada	CHECK	K.Okada		APPR.	T.Anzai		

5-12 Flatbed

5-12-1 FB Top Cover fi-6240/fi-6230

NOTICE

- Refer to Section 3-30 for the part number of the replacement part.
- Refer to Appendix for the specification of the screws.

<Removal>

Remove Flatbed.

Referring to Section 5-7 “Removing Flatbed,” remove the Flatbed.

1. Remove Document Cover.

(1) Referring to Section 5-12-9 “Document Cover,” remove the Document Cover.

2. Remove FB Top Cover.

- (2) - Remove two screws C (circles below) on the FB Top Cover. 1
- Lifting up the ADF side of the FB Top Cover, remove the FB Top Cover. 2
 - From the back of the FB Top Cover, push two tabs (squares below) of the FB TOP SIDE with a flat-blade screwdriver to remove. 3

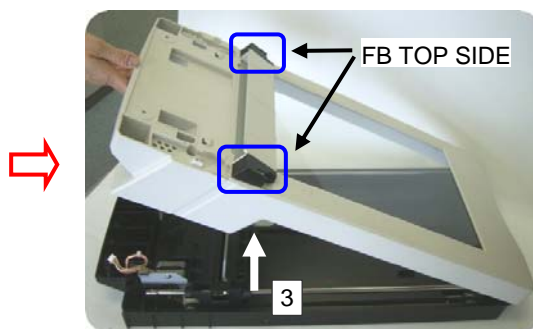
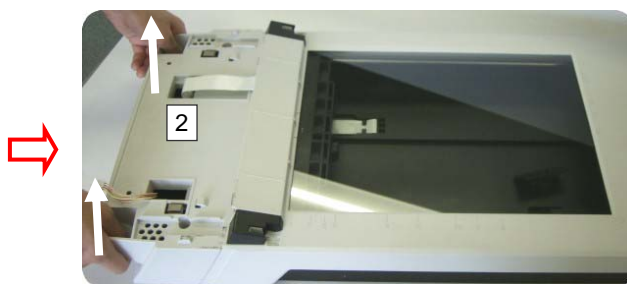
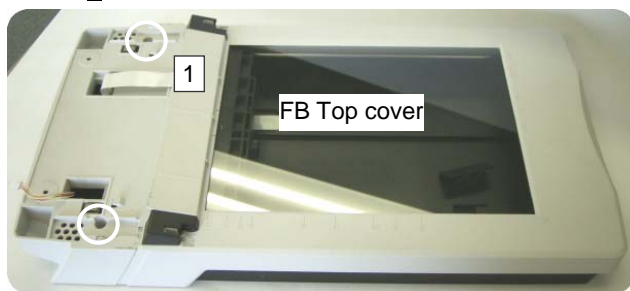

<Installation>

Follow the removing procedure in reverse.

						TITLE	fi-6140/fi-6240/fi-6130/fi-6230/fi-614PR Maintenance Manual		
08	July 27, 09	K.Okada	A.Miyoshi	I.Fujioka	Refer to Revision Record on page 2.	DRAW	P1PA03540-B0XX/6	CUST.	
07	Nov.12, 08	K.Okada	T.Anzai	I.Fujioka	Refer to Revision Record on page 2.	No.			
06	Mar.10, 08	K.Okada	T.Anzai	I.Fujioka	Refer to Revision Record on page 2.				
Rev.	DATE	DESIGN	CHECK	APPR.	DESCRIPTION	PFU LIMITED		Page	133 / 257
Design	July 27, 2007	K.Okada	CHECK	K.Okada		APPR.	T.Anzai		

5-12-2 FB Motor Unit **fi-6240/fi-6230**

NOTICE

Refer to Section 3-31 for the part number of the replacement part.
 - Refer to Appendix for the specification of the screws.

<Removal>

Remove Flatbed.

Referring to Section 5-7 “Removing Flatbed,” remove the Flatbed.

1. Remove Document Cover.

(1) Referring to Section 5-12-9 “Document Cover,” remove the Document Cover.

2. Remove FB Top Cover.

(2) Referring to step (2) of Section 5-12-1 “FB Top Cover,” remove the FB Top Cover.

3. Remove FB Motor Unit.

(3) - Remove two screws C(circles below) of the FB Motor Unit. **1**.
 - Move the CR Shaft near the FB Motor Unit outward. **2**

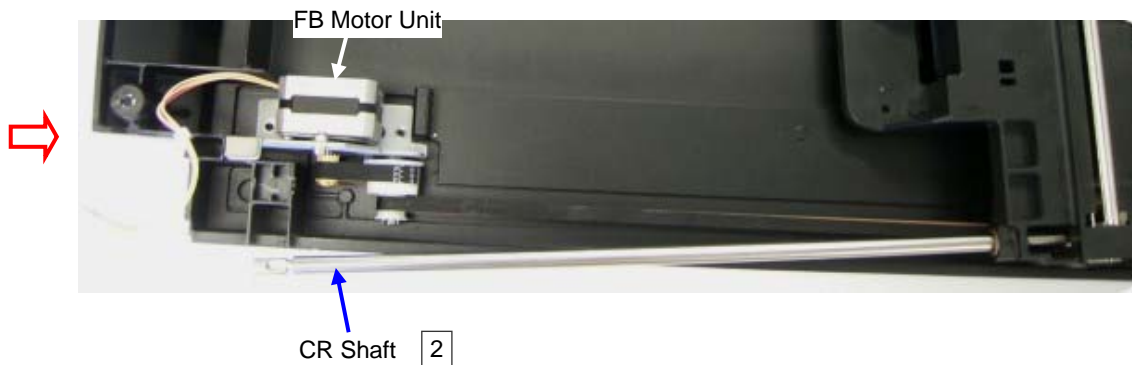
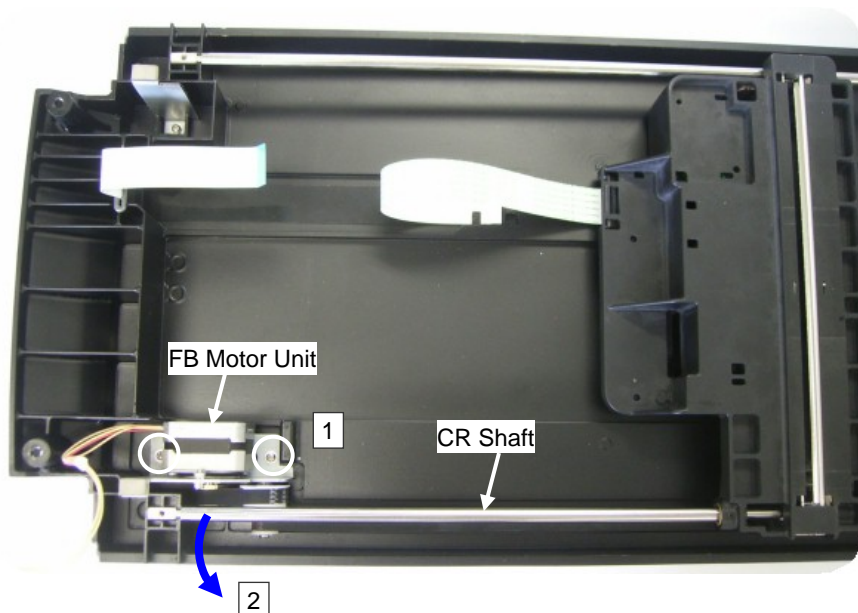

						TITLE	fi-6140/fi-6240/fi-6130/fi-6230/fi-614PR Maintenance Manual		
08	July 27, 09	K.Okada	A.Miyoshi	I.Fujioka	Refer to Revision Record on page 2.	DRAW	No. P1PA03540-B0XX/6	CUST.	
07	Nov.12, 08	K.Okada	T.Anzai	I.Fujioka	Refer to Revision Record on page 2.	No.			
06	Mar.10, 08	K.Okada	T.Anzai	I.Fujioka	Refer to Revision Record on page 2.				
Rev.	DATE	DESIGN	CHECK	APPR.	DESCRIPTION	PFU LIMITED		Page	134 / 257
Design	July 27, 2007	K.Okada	CHECK	K.Okada		APPR.	T.Anzai		

(4) Unfasten the FB Belt from the FB Motor Unit [1], and then remove the FB Motor Unit. [2]

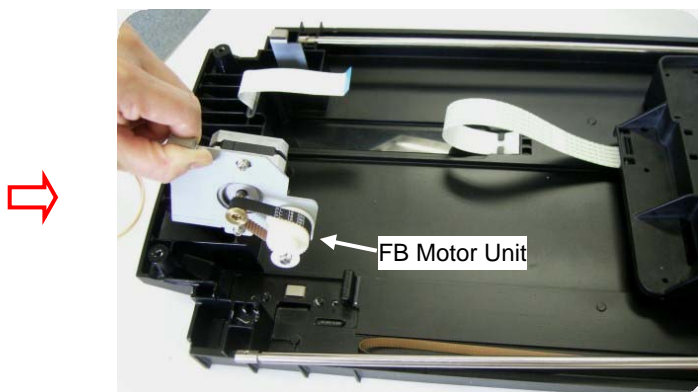
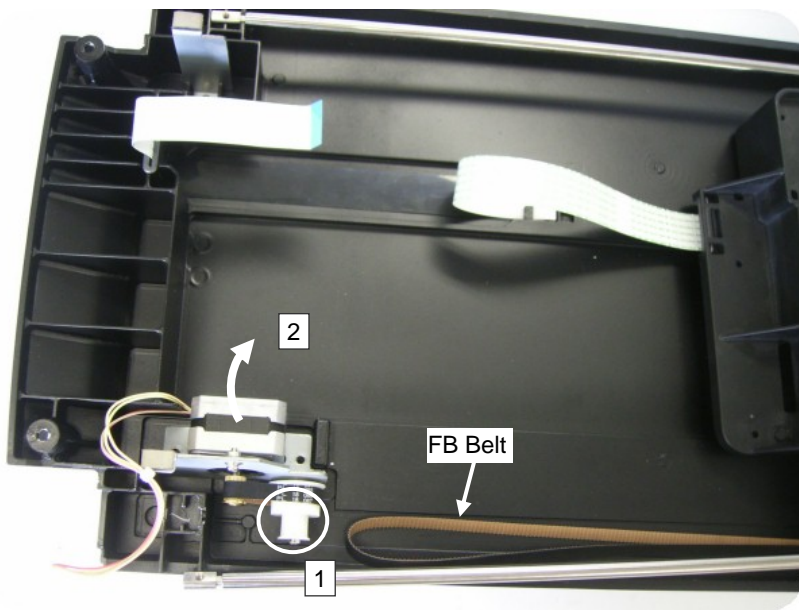

						TITLE	fi-6140/fi-6240/fi-6130/fi-6230/fi-614PR Maintenance Manual		
08	July 27, 09	K.Okada	A.Miyoshi	I.Fujioka	Refer to Revision Record on page 2.	DRAW	P1PA03540-B0XX/6	CUST.	
07	Nov.12, 08	K.Okada	T.Anzai	I.Fujioka	Refer to Revision Record on page 2.	No.			
06	Mar.10, 08	K.Okada	T.Anzai	I.Fujioka	Refer to Revision Record on page 2.				
Rev.	DATE	DESIGN	CHECK	APPR.	DESCRIPTION	PFU LIMITED		Page	135 / 257
Design	July 27, 2007	K.Okada	CHECK	K.Okada		APPR.	T.Anzai		

<Installation>

Follow the removing procedure in reverse.

Note: Adjust the FB belt tension.

- (1) Hook the FB Belt onto the FB Motor and the adjusting pulley, and then temporarily joint the adjusting plate.

Do NOT install the OPT Box Unit.

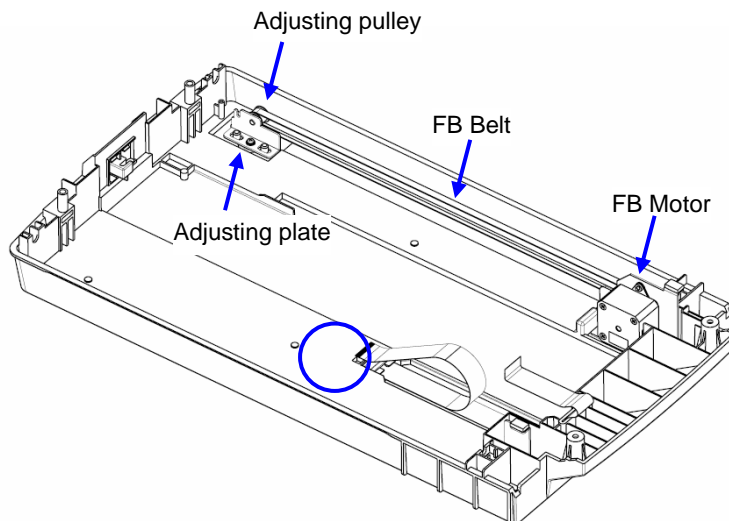

- (2) - Place the belt tension adjusting spring that is attached to the Maintenance Part as shown below.
 - Tighten the screw C (circle below).
 - Remove the belt tension adjusting spring.

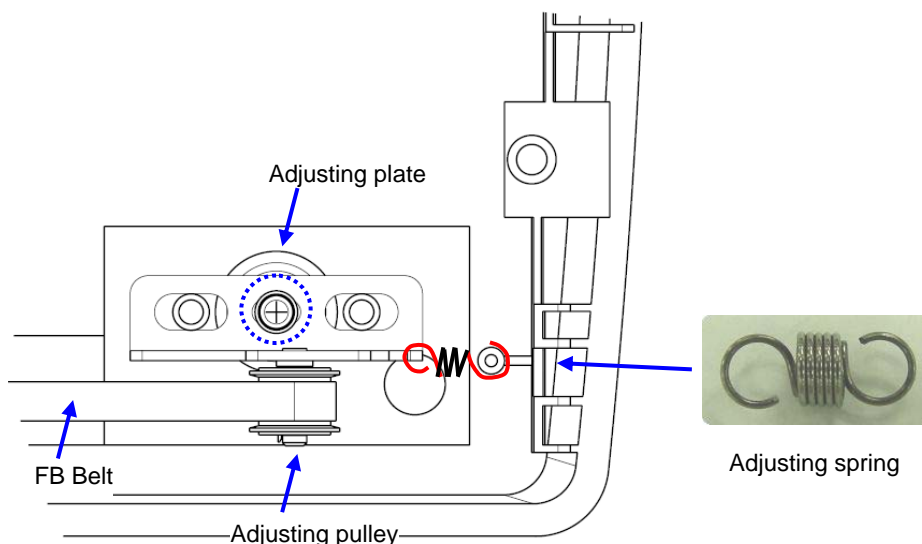

						TITLE	fi-6140/fi-6240/fi-6130/fi-6230/fi-614PR Maintenance Manual		
08	July 27, 09	K.Okada	A.Miyoshi	I.Fujioka	Refer to Revision Record on page 2.	DRAW	P1PA03540-B0XX/6	CUST.	
07	Nov.12, 08	K.Okada	T.Anzai	I.Fujioka	Refer to Revision Record on page 2.	No.			
06	Mar.10, 08	K.Okada	T.Anzai	I.Fujioka	Refer to Revision Record on page 2.				
Rev.	DATE	DESIGN	CHECK	APPR.	DESCRIPTION	PFU LIMITED		Page	136 / 257
Design	July 27, 2007	K.Okada	CHECK	K.Okada		APPR.	T.Anzai		

(3) Check the belt tension.

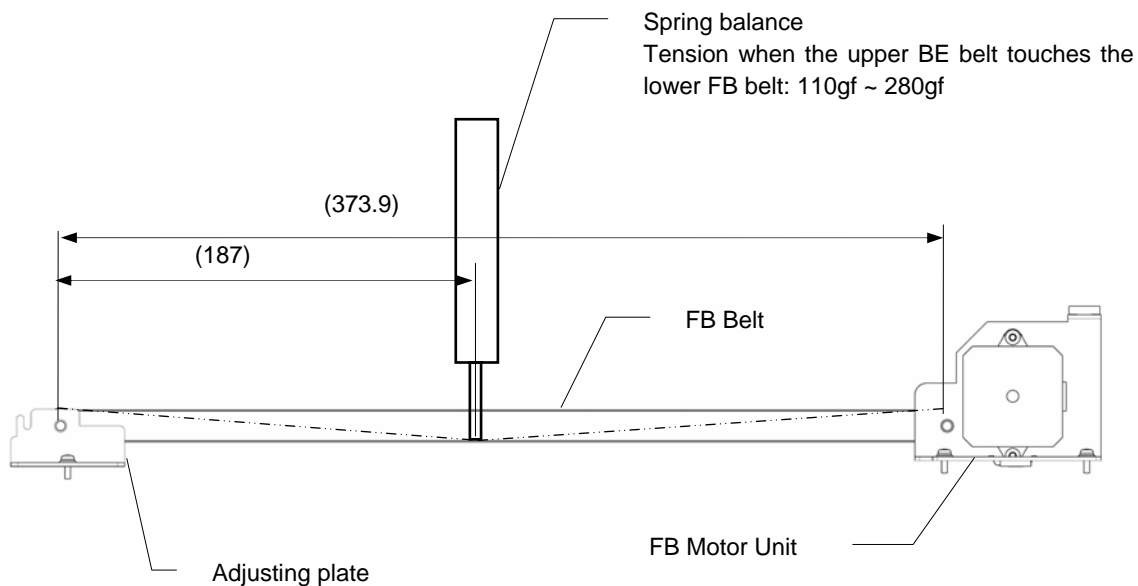

Note: Perform the following adjustments after replacing the parts.

- Referring to Section 6-1-3 "Maintenance Mode #2," adjust the magnification.
- Referring to Section 6-1-4 "Maintenance Mode #3," adjust the offset.
- Referring to Section 6-1-5 "Maintenance Mode #4," adjust the white level.

						TITLE	fi-6140/fi-6240/fi-6130/fi-6230/fi-614PR Maintenance Manual		
08	July 27, 09	K.Okada	A.Miyoshi	I.Fujioka	Refer to Revision Record on page 2.	DRAW No.	P1PA03540-B0XX/6	CUST.	
07	Nov.12, 08	K.Okada	T.Anzai	I.Fujioka	Refer to Revision Record on page 2.				
06	Mar.10, 08	K.Okada	T.Anzai	I.Fujioka	Refer to Revision Record on page 2.				
Rev.	DATE	DESIGN	CHECK	APPR.	DESCRIPTION	PFU LIMITED		Page	137 / 257
Design	July 27, 2007	K.Okada	CHECK	K.Okada					

5-12-3 FB Motor **fi-6240/fi-6230****NOTICE**

- Refer to Section 3-32 for the part number of the replacement part.
- Refer to Appendix for the specification of the screws.

<Removal>

Remove Flatbed.

Referring to Section 5-7 “Removing Flatbed,” remove the Flatbed.

1. Remove Document Cover.

(1) Referring to Section 5-12-9 “Document Cover,” remove the Document Cover.

2. Remove FB Top Cover.

(2) Referring to step (2) of Section 5-12-1 “FB Top Cover,” remove the FB Top Cover.

3. Remove FB Motor Unit.

(3) Referring to steps (3) ~ (4) of Section 5-12-2 “FB Motor Unit,” remove the FB Motor Unit.

4. Remove FB Motor.

- (4) - Remove two screws C (circles below) of the FB Motor.
 - Remove the FB Motor belt.

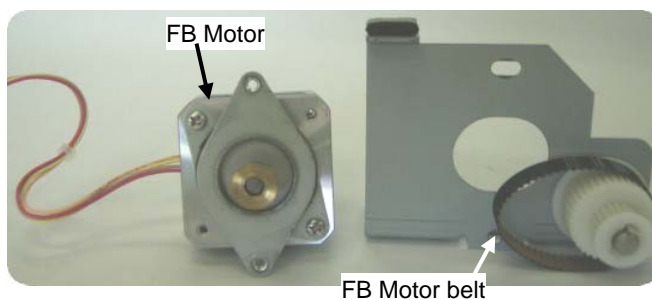
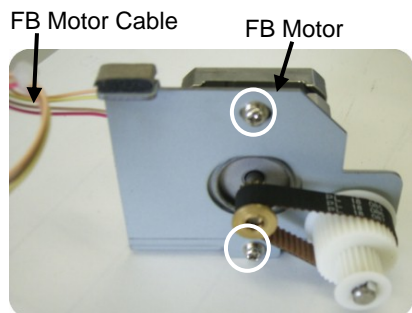

<Installation>

Follow the removing procedure in reverse.

Note: Adjust the FB motor belt tension.

Rev.	DATE	DESIGN	CHECK	APPR.	DESCRIPTION	TITLE		
08	July 27, 09	K.Okada	A.Miyoshi	I.Fujioka	Refer to Revision Record on page 2.	fi-6140/fi-6240/fi-6130/fi-6230/fi-614PR Maintenance Manual		
07	Nov.12, 08	K.Okada	T.Anzai	I.Fujioka	Refer to Revision Record on page 2.	DRAW No.	P1PA03540-B0XX/6	CUST.
06	Mar.10, 08	K.Okada	T.Anzai	I.Fujioka	Refer to Revision Record on page 2.			
Design	July 27, 2007	K.Okada	CHECK	K.Okada		PFU LIMITED	Page	138 / 257

Place the FB Motor as shown below,
and screw the FB Motor with its own weight.

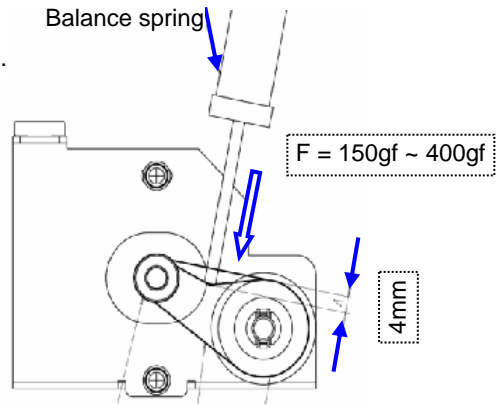
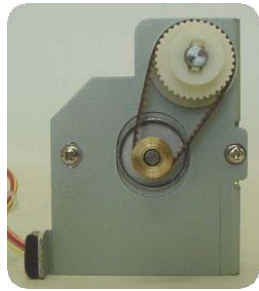

						TITLE	fi-6140/fi-6240/fi-6130/fi-6230/fi-614PR Maintenance Manual		
08	July 27, 09	K.Okada	A.Miyoshi	I.Fujioka	Refer to Revision Record on page 2.	DRAW No.	P1PA03540-B0XX/6	CUST.	
07	Nov.12, 08	K.Okada	T.Anzai	I.Fujioka	Refer to Revision Record on page 2.				
06	Mar.10, 08	K.Okada	T.Anzai	I.Fujioka	Refer to Revision Record on page 2.				
Rev.	DATE	DESIGN	CHECK	APPR.	DESCRIPTION	PFU LIMITED		Page	139 / 257
Design	July 27, 2007	K.Okada	CHECK	K.Okada		APPR.	T.Anzai		

5-12-4 OPT Box Unit **fi-6240/fi-6230****NOTICE**

- The OPT Unit, Joint PCA, core, and Inverter cable are not included.
- The Inverter and Lamp are included.
- Re-install the OPT Unit, Joint PCA, core and Inverter cable.
- Refer to Section 3-33 for the part number of the replacement part.

<Removal>

Remove Flatbed.

Referring to Section 5-7 "Removing Flatbed," remove the Flatbed.

1. Remove Document Cover.

(1) Referring to Section 5-12-9 "Document Cover," remove the Document Cover.

2. Remove FB Top Cover.

(2) Referring to step (2) of Section 5-12-1 "FB Top Cover," remove the FB Top Cover.

3. Remove OPT Box Unit.

- (3) - Remove the FB Belt from the OPT Box Unit. **1**
- Lifting up the CR cable side of the OPT Box Unit **2**, remove the CR shaft outward **3**.
 - Disconnect the CR cable at the bottom of the OPT Box Unit. **4**

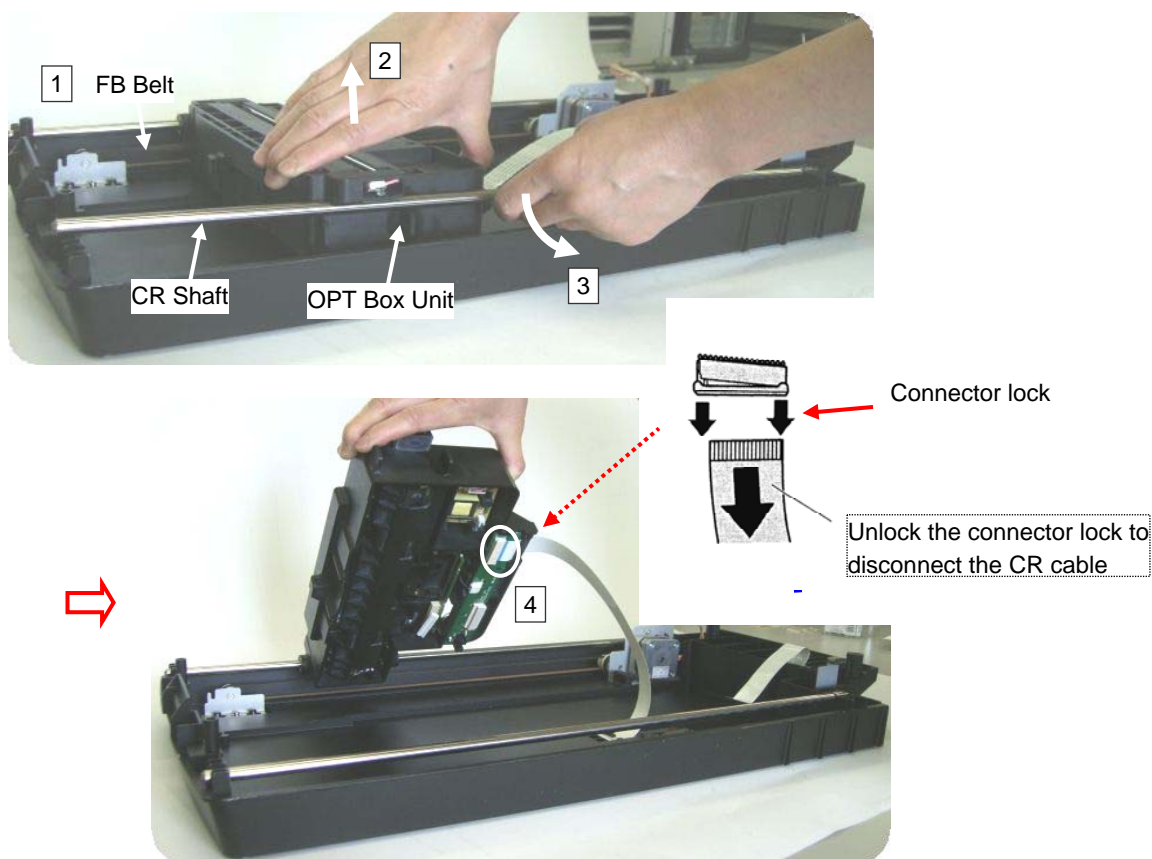

Rev.	DATE	DESIGN	CHECK	APPR.	DESCRIPTION	TITLE			
08	July 27, 09	K.Okada	A.Miyoshi	I.Fujioka	Refer to Revision Record on page 2.	fi-6140/fi-6240/fi-6130/fi-6230/fi-614PR Maintenance Manual			
07	Nov.12, 08	K.Okada	T.Anzai	I.Fujioka	Refer to Revision Record on page 2.	DRAW No.	P1PA03540-B0XX/6	CUST.	
06	Mar.10, 08	K.Okada	T.Anzai	I.Fujioka	Refer to Revision Record on page 2.				
Design	July 27, 2007	K.Okada	CHECK	K.Okada	APPR.	T.Anzai	PFU LIMITED	Page	140 / 257

(4) Lifting up the FB Motor side of the OPT Box Unit [1], move the OPT Box Unit outward [2], and then remove the CR shaft [3].

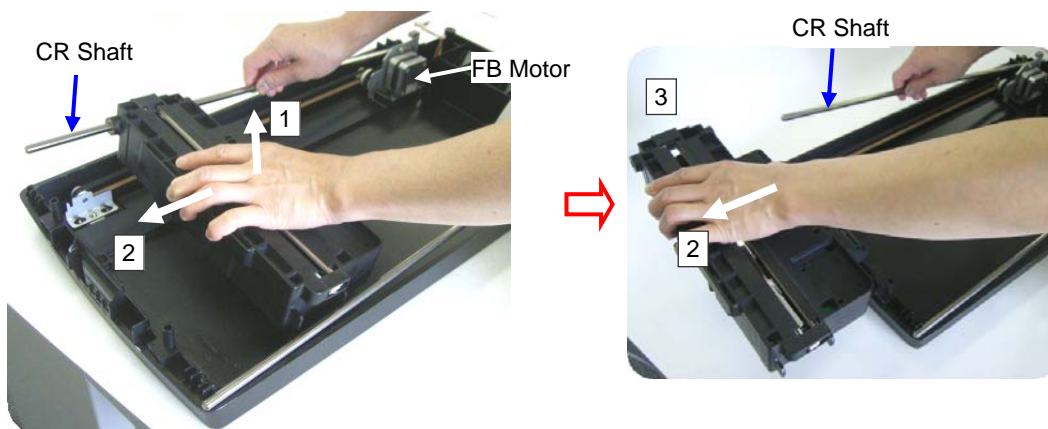

4. Remove OPT Unit.

(5) Referring to step (4) of Section 5-12-5 “OPT Unit,” remove the OPT Unit.

5. Remove Joint PCA.

(6) Referring to Step (4) of Section 5-12-10 “Joint PCA,” remove the Joint PCA.

6. Remove the core and Inverter cable.

(7) Remove the core and Inverter cable.

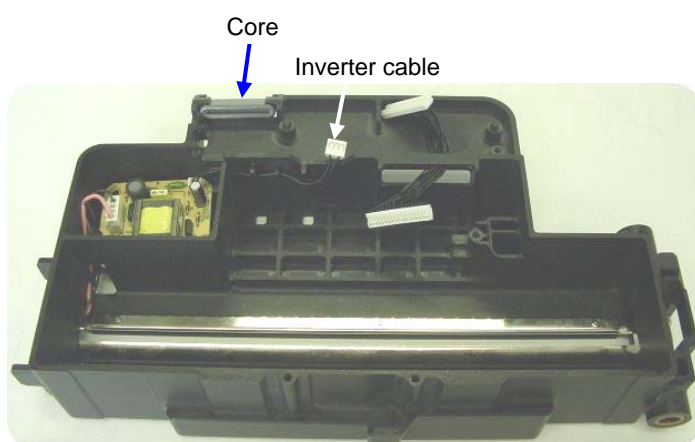

						TITLE	fi-6140/fi-6240/fi-6130/fi-6230/fi-614PR Maintenance Manual		
08	July 27, 09	K.Okada	A.Miyoshi	I.Fujioka	Refer to Revision Record on page 2.	DRAW	P1PA03540-B0XX/6	CUST.	
07	Nov.12, 08	K.Okada	T.Anzai	I.Fujioka	Refer to Revision Record on page 2.	No.			
06	Mar.10, 08	K.Okada	T.Anzai	I.Fujioka	Refer to Revision Record on page 2.				
Rev.	DATE	DESIGN	CHECK	APPR.	DESCRIPTION	PFU LIMITED		Page	141 / 257
Design	July 27, 2007	K.Okada	CHECK	K.Okada		APPR.	T.Anzai		

<Installation>

Follow the removing procedure in reverse.

Note: Re-install the OPT Unit, Joint PCA, core and Inverter cable.

Note: Thread the CR cable through the OPT Box Unit core.

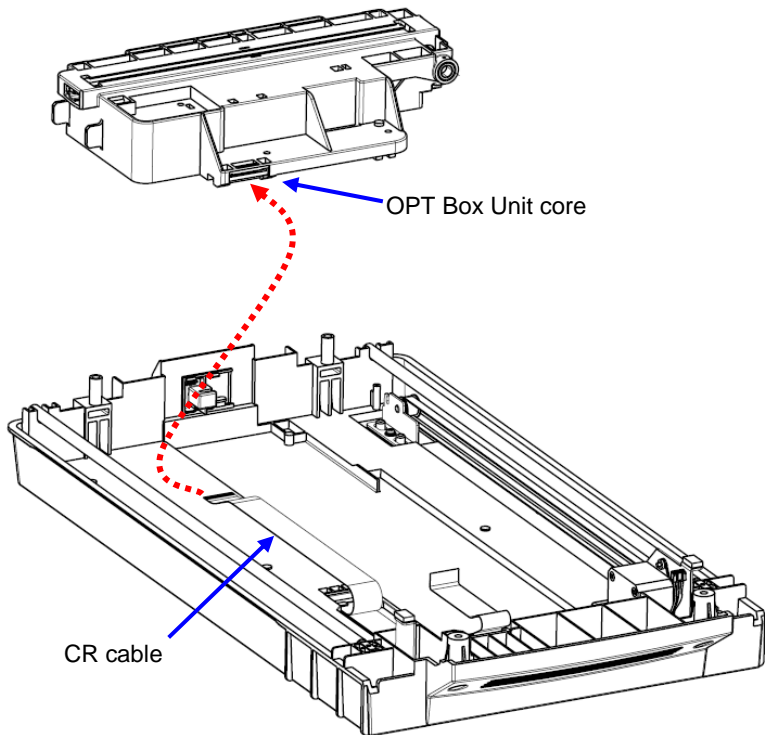

Note: Install the FB Belt to the OPT Box Unit.

Note: Perform the following adjustments after replacing the parts.

- Referring to Section 6-1-3 “Maintenance Mode #2,” adjust the magnification.
- Referring to Section 6-1-4 “Maintenance Mode #3,” adjust the offset.
- Referring to Section 6-1-5 “Maintenance Mode #4,” adjust the white level.

						TITLE	fi-6140/fi-6240/fi-6130/fi-6230/fi-614PR Maintenance Manual		
08	July 27, 09	K.Okada	A.Miyoshi	I.Fujioka	Refer to Revision Record on page 2.	DRAW	P1PA03540-B0XX/6	CUST.	
07	Nov.12, 08	K.Okada	T.Anzai	I.Fujioka	Refer to Revision Record on page 2.	No.			
06	Mar.10, 08	K.Okada	T.Anzai	I.Fujioka	Refer to Revision Record on page 2.				
Rev.	DATE	DESIGN	CHECK	APPR.	DESCRIPTION	PFU LIMITED		Page	142 / 257
Design	July 27, 2007	K.Okada	CHECK	K.Okada		APPR.	T.Anzai		

5-12-5 OPT Unit **fi-6240/fi-6230**

NOTICE

- Refer to Section 3-6 for the part number of the replacement part.
- Refer to Appendix for the specification of the screws.

<Removal>

Remove Flatbed.

Referring to Section 5-7 “Removing Flatbed,” remove the Flatbed.

1. Remove Document Cover.

(1) Referring to Section 5-12-9 “Document Cover,” remove the Document Cover.

2. Remove FB Top Cover.

(2) Referring to step (2) of Section 5-12-1 “FB Top Cover,” remove the FB Top Cover.

3. Remove OPT Box Unit.

(3) Referring to steps (3) ~ (4) of Section 5-12-4 “OPT Box Unit,” remove the OPT Box Unit.

4. Remove Joint PCA.

(4) Referring to step (4) of Section 5-12-10 “Joint PCA,” remove the Joint PCA.

5. Remove OPT Unit.

(5) - Disconnect the CCD cable. **1**

Note: Pinching the root of connector of the CCD board to support, pull out the CCD cable straight.

- Remove the screw A (circle below) on the OPT Hold plate, and then remove the OPT Hold plate. **2**
- Lift up the OPT Unit at 45 degrees **3**, and then remove the OPT Unit **4**.

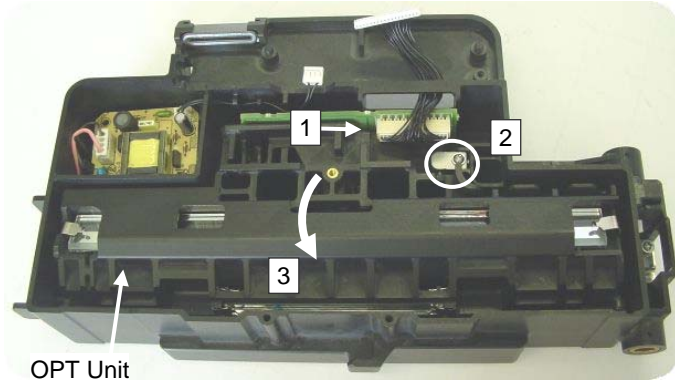

OPT Unit

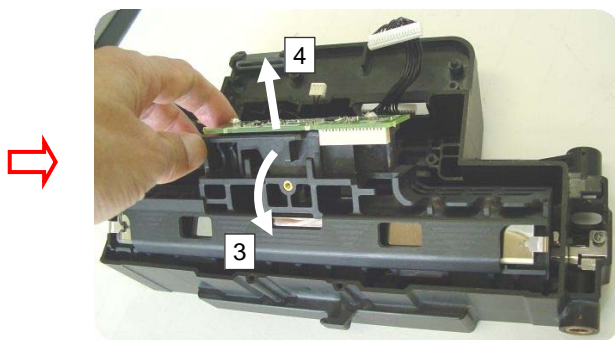

						TITLE	fi-6140/fi-6240/fi-6130/fi-6230/fi-614PR Maintenance Manual		
08	July 27, 09	K.Okada	A.Miyoshi	I.Fujioka	Refer to Revision Record on page 2.	DRAW No.	P1PA03540-B0XX/6	CUST.	
07	Nov.12, 08	K.Okada	T.Anzai	I.Fujioka	Refer to Revision Record on page 2.				
06	Mar.10, 08	K.Okada	T.Anzai	I.Fujioka	Refer to Revision Record on page 2.				
Rev.	DATE	DESIGN	CHECK	APPR.	DESCRIPTION	PFU LIMITED		Page	143 / 257
Design	July 27, 2007	K.Okada	CHECK	K.Okada		APPR.	T.Anzai		

<Installation>

Follow the removing procedure in reverse.

Blow out the dust inside of the Glass and the OPT Unit with air before installation.

Install the OPT unit in the order of 1 → 2.

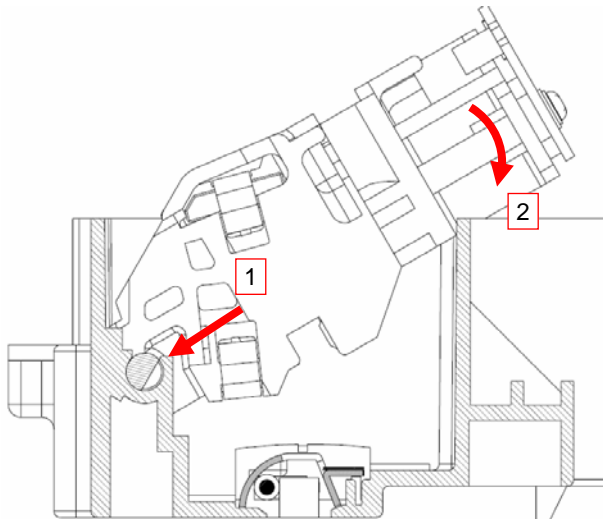

Note: Face the convex side down when installing the OPT Hold Plate.

Note: Perform the following adjustments after replacing the parts.

- Referring to Section 6-1-3 “Maintenance Mode #2,” adjust the magnification.
- Referring to Section 6-1-4 “Maintenance Mode #3,” adjust the offset.
- Referring to Section 6-1-5 “Maintenance Mode #4,” adjust the white level.

						TITLE	fi-6140/fi-6240/fi-6130/fi-6230/fi-614PR Maintenance Manual		
08	July 27, 09	K.Okada	A.Miyoshi	I.Fujioka	Refer to Revision Record on page 2.	DRAW No.	P1PA03540-B0XX/6	CUST.	
07	Nov.12, 08	K.Okada	T.Anzai	I.Fujioka	Refer to Revision Record on page 2.				
06	Mar.10, 08	K.Okada	T.Anzai	I.Fujioka	Refer to Revision Record on page 2.				
Rev.	DATE	DESIGN	CHECK	APPR.	DESCRIPTION	PFU LIMITED		Page	144 / 257
Design	July 27, 2007	K.Okada	CHECK	K.Okada		APPR.	T.Anzai		

5-12-6 Inverter **fi-6240/fi-6230**

NOTICE

Refer to Section 3-3 for the part number of the replacement part.

<Removal>

Remove Flatbed.

Referring to Section 5-7 “Removing Flatbed,” remove the Flatbed.

1. Remove Document Cover.

(1) Referring to Section 5-12-9 “Document Cover,” remove the Document Cover.

2. Remove FB Top Cover.

(2) Referring to step (2) of Section 5-12-1 “FB Top Cover,” remove the FB Top Cover.

3. Remove OPT Box Unit.

(3) Referring to steps (3) ~ (4) of Section 5-12-4 “OPT Box Unit,” remove the OPT Box Unit.

4. Remove Inverter.

(4) - Disconnect two Inverter cables (circles below).
 - Unlatch two claws at both sides of the Inverter to remove the Inverter.

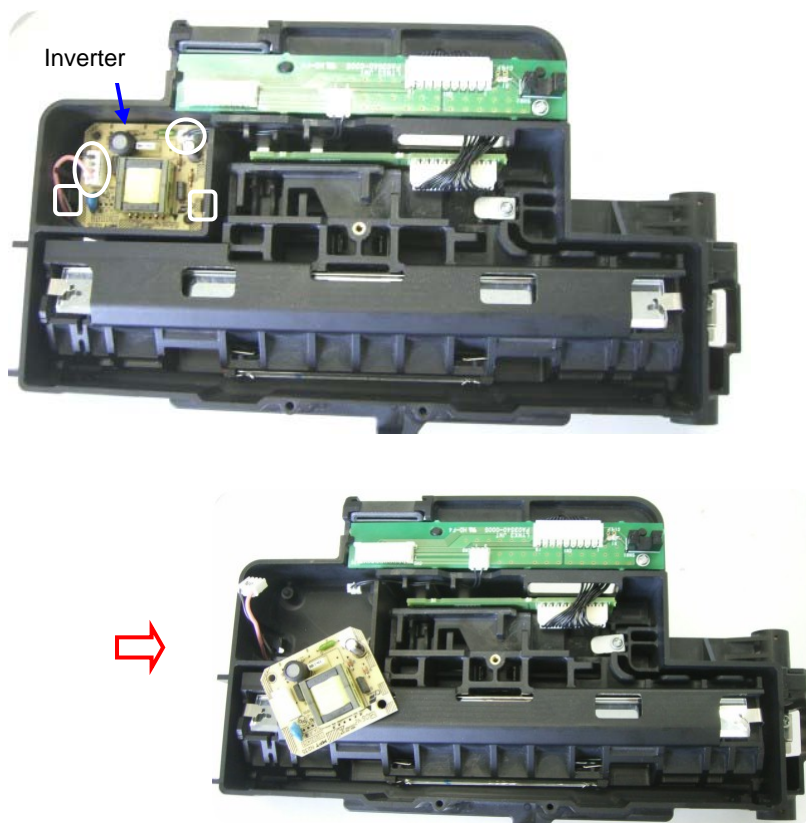

						TITLE	fi-6140/fi-6240/fi-6130/fi-6230/fi-614PR Maintenance Manual		
08	July 27, 09	K.Okada	A.Miyoshi	I.Fujioka	Refer to Revision Record on page 2.	DRAW	P1PA03540-B0XX/6	CUST.	
07	Nov.12, 08	K.Okada	T.Anzai	I.Fujioka	Refer to Revision Record on page 2.	No.			
06	Mar.10, 08	K.Okada	T.Anzai	I.Fujioka	Refer to Revision Record on page 2.				
Rev.	DATE	DESIGN	CHECK	APPR.	DESCRIPTION	PFU LIMITED		Page	145 / 257
Design	July 27, 2007	K.Okada	CHECK	K.Okada		APPR.	T.Anzai		

<Installation>

Follow the removing procedure in reverse.

Wire the Lamp cable as shown below.

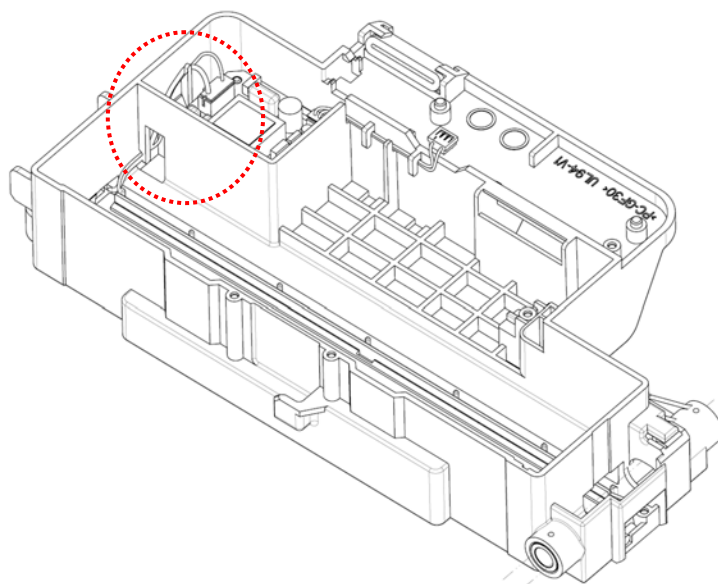

Note: Make sure that the claws at both sides of the Inverter are securely latched.

Note: Perform the following adjustments after replacing the parts.

- Referring to Section 6-1-3 "Maintenance Mode #2," adjust the magnification.
- Referring to Section 6-1-4 "Maintenance Mode #3," adjust the offset.
- Referring to Section 6-1-5 "Maintenance Mode #4," adjust the white level.

						TITLE	fi-6140/fi-6240/fi-6130/fi-6230/fi-614PR Maintenance Manual		
08	July 27, 09	K.Okada	A.Miyoshi	I.Fujioka	Refer to Revision Record on page 2.	DRAW No.	P1PA03540-B0XX/6	CUST.	
07	Nov.12, 08	K.Okada	T.Anzai	I.Fujioka	Refer to Revision Record on page 2.				
06	Mar.10, 08	K.Okada	T.Anzai	I.Fujioka	Refer to Revision Record on page 2.				
Rev.	DATE	DESIGN	CHECK	APPR.	DESCRIPTION	PFU LIMITED		Page	146 / 257
Design	July 27, 2007	K.Okada	CHECK	K.Okada	APPR.				

5-12-7 Lamp **fi-6240/fi-6230****NOTICE**

Refer to Section 3-4 for the part number of the replacement part.

- Refer to Appendix for the specification of the screws.

<Removal>

Remove Flatbed.

Referring to Section 5-7 “Removing Flatbed,” remove the Flatbed.

1. Remove Document Cover.

(1) Referring to Section 5-12-9 “Document Cover,” remove the Document Cover.

2. Remove FB Top Cover.

(2) Referring to step (2) of Section 5-12-1 “FB Top Cover,” remove the FB Top Cover.

3. Remove OPT Box Unit.

(3) Referring to steps (3) ~ (4) of Section 5-12-4 “OPT Box Unit,” remove the OPT Box Unit.

4. Remove Inverter.

(4) Referring to step (4) of Section 5-12-6, remove the Inverter.

5. Remove Lamp.

(5) - Remove the screw A (circle below) of the reflector. **1**

- Move the reflector to the right **2**, and draw it out of the OPT Box Unit **3**.

Note: Do NOT break the Lamp with the reflector.

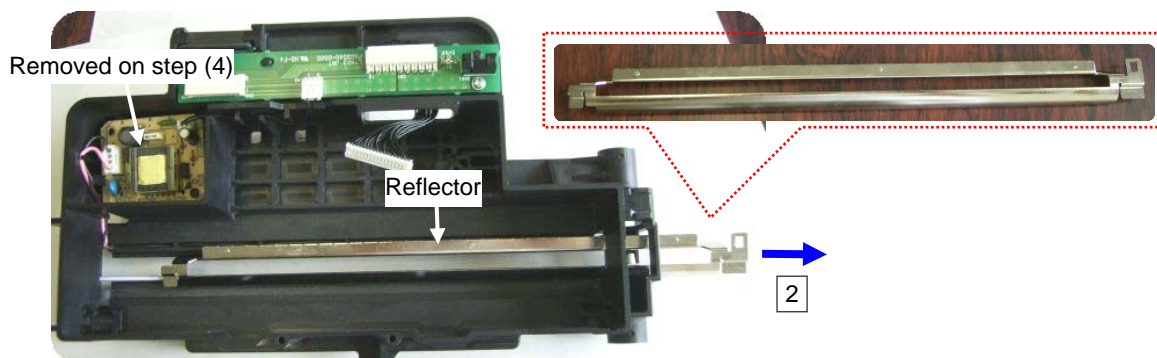
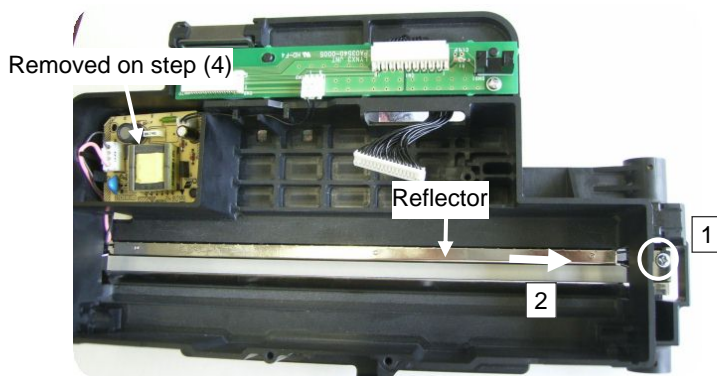

Rev.	DATE	DESIGN	CHECK	APPR.	DESCRIPTION	TITLE	fi-6140/fi-6240/fi-6130/fi-6230/fi-614PR Maintenance Manual	
08	July 27, 09	K.Okada	A.Miyoshi	I.Fujioka	Refer to Revision Record on page 2.	DRAW No.	P1PA03540-B0XX/6	CUST.
07	Nov.12, 08	K.Okada	T.Anzai	I.Fujioka	Refer to Revision Record on page 2.			
06	Mar.10, 08	K.Okada	T.Anzai	I.Fujioka	Refer to Revision Record on page 2.			
Design	July 27, 2007	K.Okada	CHECK	K.Okada	APPR.	T.Anzai	PFU LIMITED	Page 147 / 257

- (6) - Remove the thin cable from the groove of the frame.
- Remove the Lamp.

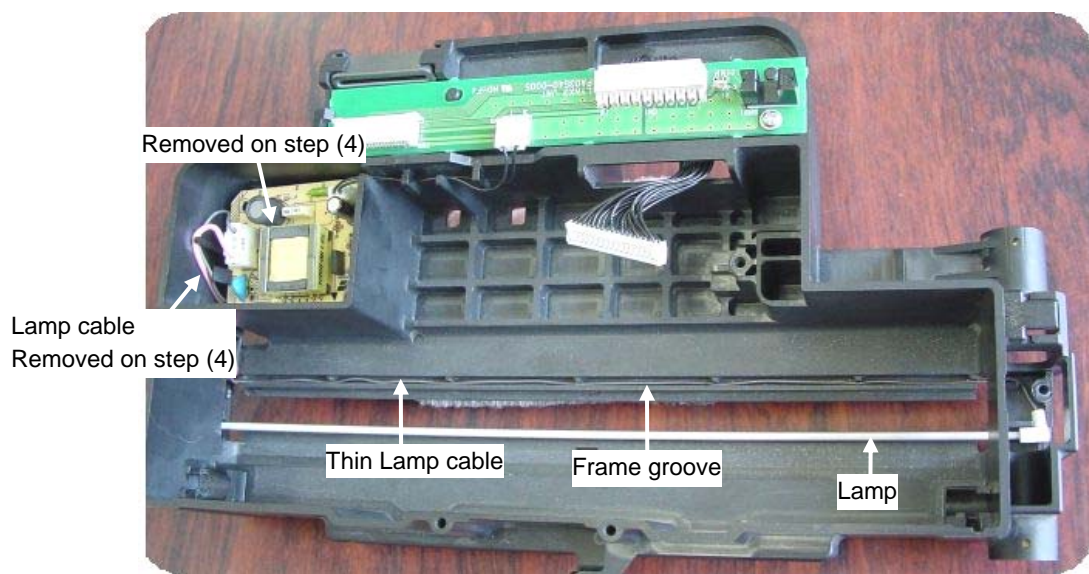

						TITLE	fi-6140/fi-6240/fi-6130/fi-6230/fi-614PR Maintenance Manual		
08	July 27, 09	K.Okada	A.Miyoshi	I.Fujioka	Refer to Revision Record on page 2.	DRAW No.	P1PA03540-B0XX/6	CUST.	
07	Nov.12, 08	K.Okada	T.Anzai	I.Fujioka	Refer to Revision Record on page 2.				
06	Mar.10, 08	K.Okada	T.Anzai	I.Fujioka	Refer to Revision Record on page 2.				
Rev.	DATE	DESIGN	CHECK	APPR.	DESCRIPTION	PFU LIMITED		Page	148 / 257
Design	July 27, 2007	K.Okada	CHECK	K.Okada		APPR.	T.Anzai		

<Installation>

Follow the removing procedure in reverse.

- (1) - Install the Lamp to the frame, and then route the thin Lamp cable on the groove of the frame.
- Connect the Lamp cable to the Inverter (solid circle below).

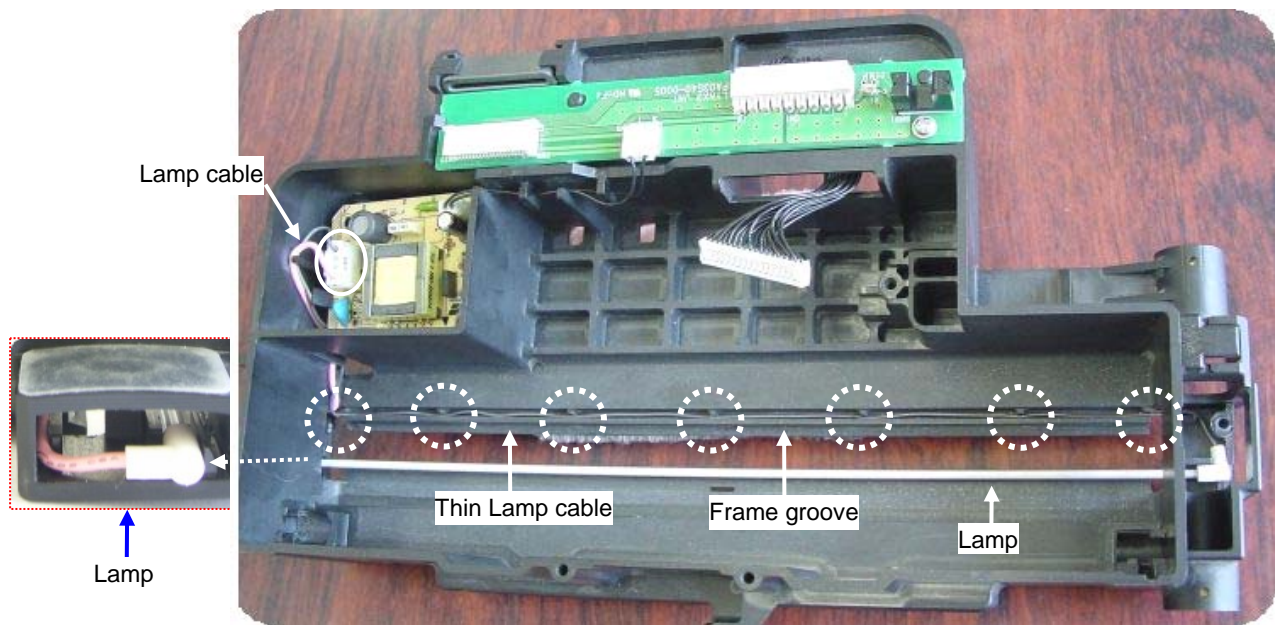

- (2) Install the reflector to the frame.

Note: Make sure that the protrusions of the reflector are inserted into the holes of the frame.

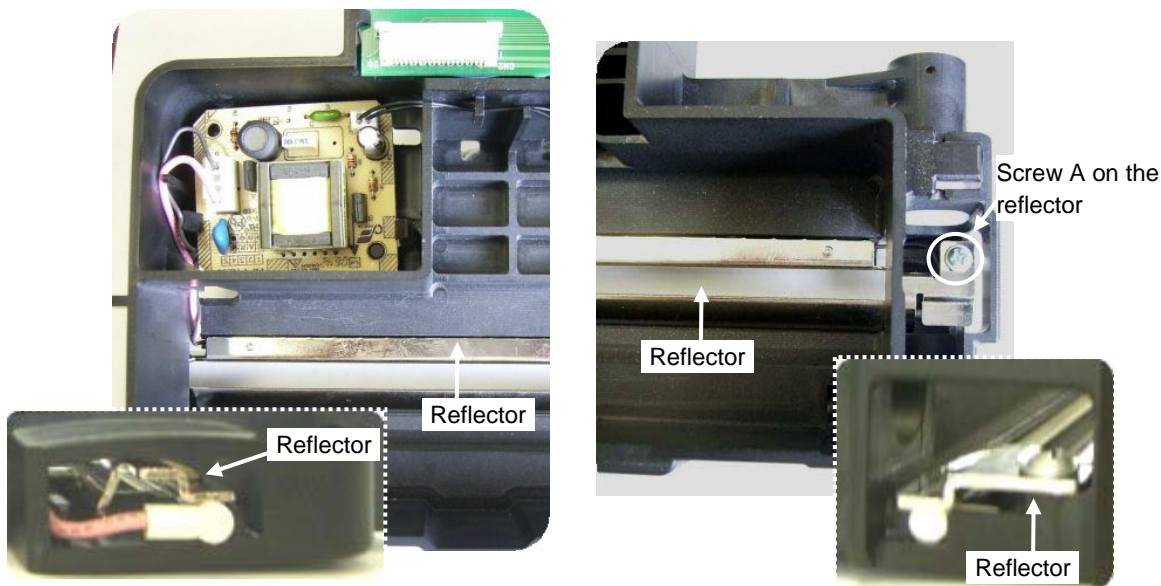

Note: Perform the following adjustments after replacing the parts.

- Referring to Section 6-1-3 "Maintenance Mode #2," adjust the magnification.
- Referring to Section 6-1-4 "Maintenance Mode #3," adjust the offset.
- Referring to Section 6-1-5 "Maintenance Mode #4," adjust the white level.

						TITLE	fi-6140/fi-6240/fi-6130/fi-6230/fi-614PR Maintenance Manual		
08	July 27, 09	K.Okada	A.Miyoshi	I.Fujioka	Refer to Revision Record on page 2.	DRAW	P1PA03540-B0XX/6	CUST.	
07	Nov.12, 08	K.Okada	T.Anzai	I.Fujioka	Refer to Revision Record on page 2.	No.			
06	Mar.10, 08	K.Okada	T.Anzai	I.Fujioka	Refer to Revision Record on page 2.				
Rev.	DATE	DESIGN	CHECK	APPR.	DESCRIPTION	PFU LIMITED		Page	149 / 257
Design	July 27, 2007	K.Okada	CHECK	K.Okada		APPR.	T.Anzai		

5-12-8 CR Cable **fi-6240/fi-6230**

NOTICE

Refer to Section 3-37 for the part number of the replacement part.

<Removal>

Remove Flatbed.

Referring to Section 5-7 “Removing Flatbed,” remove the Flatbed.

1. Remove Document Cover.

(1) Referring to Section 5-12-9 “Document Cover,” remove the Document Cover.

2. Remove FB Top Cover.

(2) Referring to step (2) of Section 5-12-1 “FB Top Cover,” remove the FB Top Cover.

3. Remove OPT Box Unit.

(3) Referring to steps (3) ~ (4) of Section 5-12-4 “OPT Box Unit,” remove the OPT Box Unit.

4. Remove CR Cable.

(4) Lift up the core to remove.

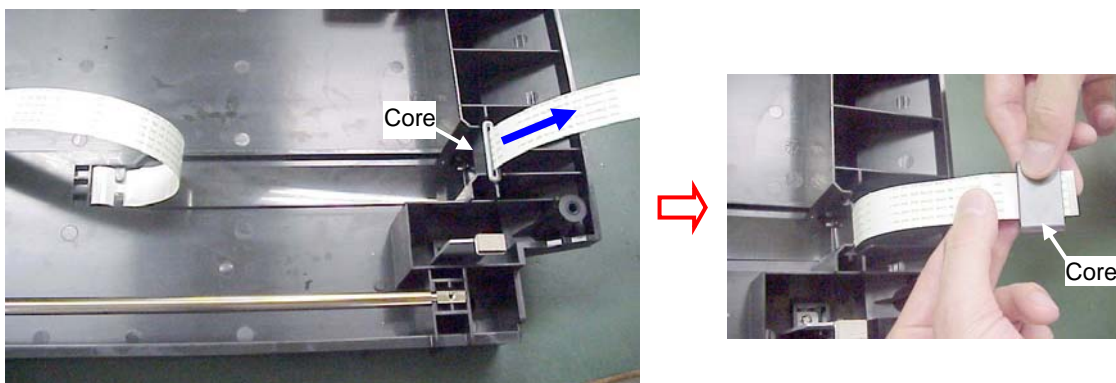

(5) Move the CR Cable to the left, and then unhook it from the claws (square below) of the frame.

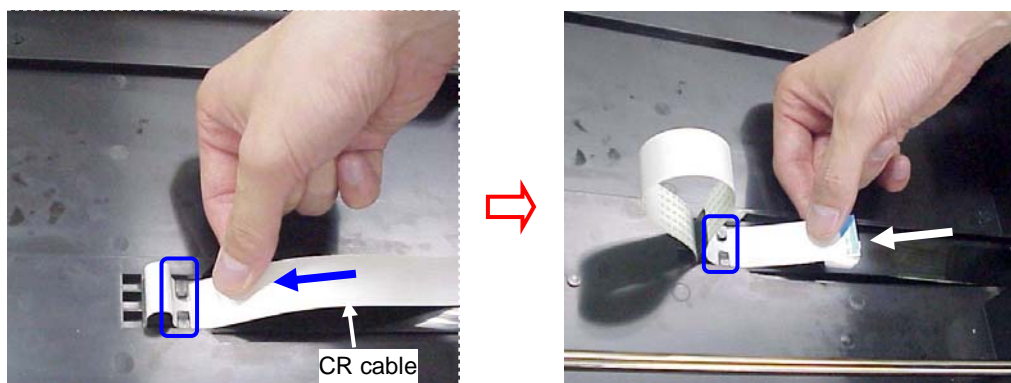

						TITLE	fi-6140/fi-6240/fi-6130/fi-6230/fi-614PR Maintenance Manual		
08	July 27, 09	K.Okada	A.Miyoshi	I.Fujioka	Refer to Revision Record on page 2.	DRAW	P1PA03540-B0XX/6	CUST.	
07	Nov.12, 08	K.Okada	T.Anzai	I.Fujioka	Refer to Revision Record on page 2.	No.			
06	Mar.10, 08	K.Okada	T.Anzai	I.Fujioka	Refer to Revision Record on page 2.				
Rev.	DATE	DESIGN	CHECK	APPR.	DESCRIPTION	PFU LIMITED		Page	150 / 257
Design	July 27, 2007	K.Okada	CHECK	K.Okada		APPR.	T.Anzai		

- (4) - Unhook the CR Sheet from two claws (squares below) of the frame. **1**
- Unhook the CR Cable from two claws (squares below) of the frame. **2**

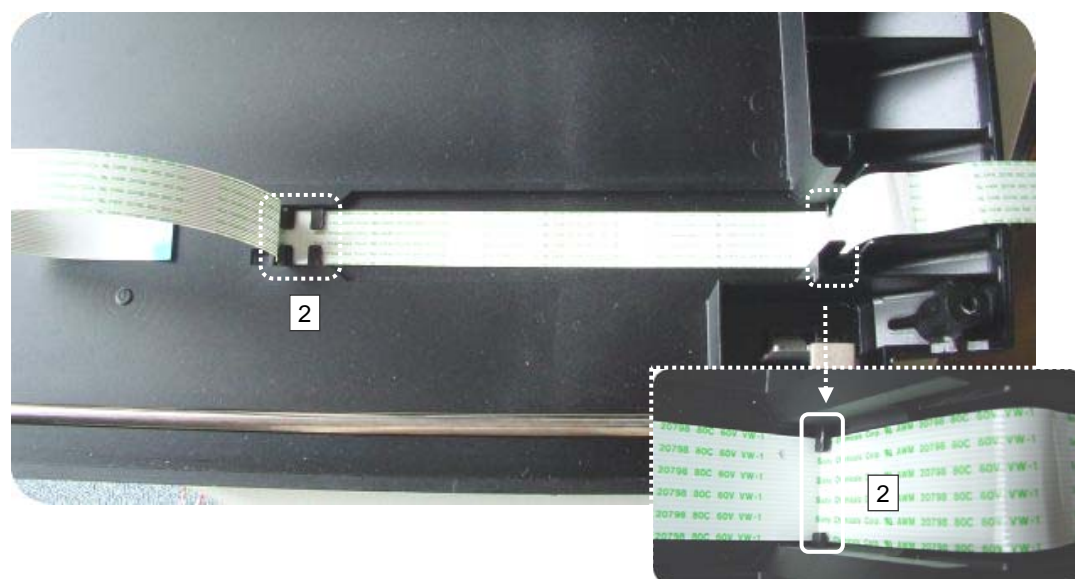
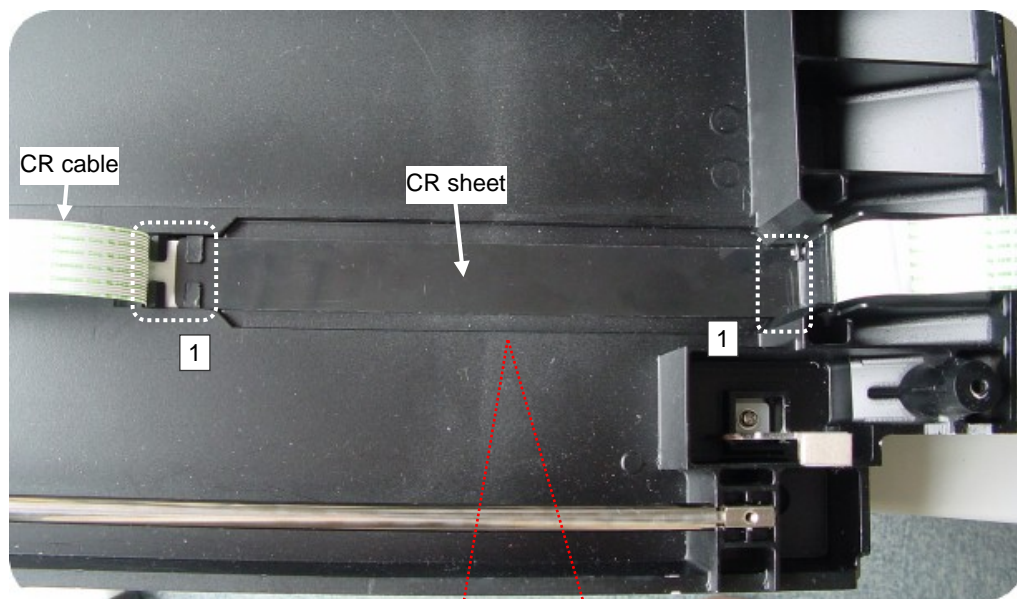

						TITLE	fi-6140/fi-6240/fi-6130/fi-6230/fi-614PR Maintenance Manual		
08	July 27, 09	K.Okada	A.Miyoshi	I.Fujioka	Refer to Revision Record on page 2.	DRAW	P1PA03540-B0XX/6	CUST.	
07	Nov.12, 08	K.Okada	T.Anzai	I.Fujioka	Refer to Revision Record on page 2.	No.			
06	Mar.10, 08	K.Okada	T.Anzai	I.Fujioka	Refer to Revision Record on page 2.				
Rev.	DATE	DESIGN	CHECK	APPR.	DESCRIPTION	PFU LIMITED		Page	151 / 257
Design	July 27, 2007	K.Okada	CHECK	K.Okada		APPR.	T.Anzai		

<Installation>

Follow the removing procedure in reverse.

Note: With white face of the CR Cable down, lead the shorter bent side under the hook of the frame.

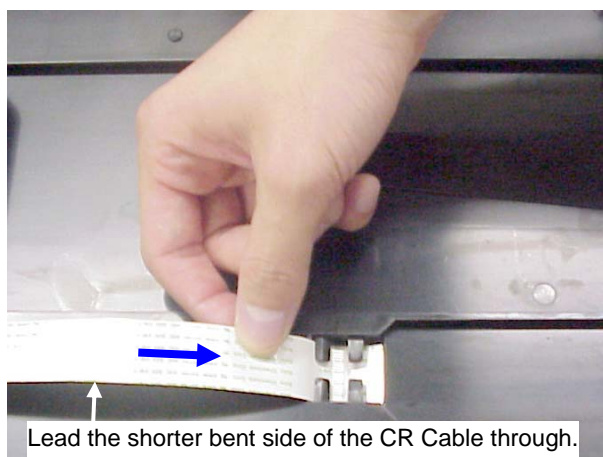

Note: Lead the shorter bent side under the hook of the frame.



						TITLE	fi-6140/fi-6240/fi-6130/fi-6230/fi-614PR Maintenance Manual		
08	July 27, 09	K.Okada	A.Miyoshi	I.Fujioka	Refer to Revision Record on page 2.	DRAW	P1PA03540-B0XX/6	CUST.	
07	Nov.12, 08	K.Okada	T.Anzai	I.Fujioka	Refer to Revision Record on page 2.	No.			
06	Mar.10, 08	K.Okada	T.Anzai	I.Fujioka	Refer to Revision Record on page 2.				
Rev.	DATE	DESIGN	CHECK	APPR.	DESCRIPTION	PFU LIMITED		Page	152 / 257
Design	July 27, 2007	K.Okada	CHECK	K.Okada		APPR.	T.Anzai		

5-12-9 Document Cover **fi-6240/fi-6230**

NOTICE

Refer to Section 3-38 for the part number of the replacement part.

<Removal>

I. Remove Document Cover.

- (1) Open the Document Cover, and then lift it up.



<Installation>

Follow the removing procedure in reverse.

Paste the cushion attached to the Maintenance part to the Document Cover.

- (1) With the white side of the cushion facing down, place the cushion on the glass surface, aligning to the lower left reference point.

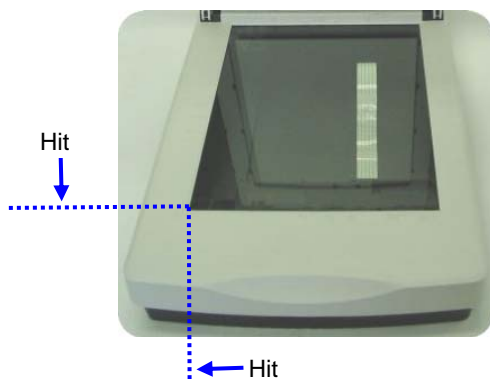

- (2) Peel off the double-sided tape of the cushion.
- (3) Close the document cover slowly to paste the document cover and cushion.
- (4) Remove the Document cover from the Flatbed, push the cushion by hand firmly.

						TITLE	fi-6140/fi-6240/fi-6130/fi-6230/fi-614PR Maintenance Manual		
08	July 27, 09	K.Okada	A.Miyoshi	I.Fujioka	Refer to Revision Record on page 2.	DRAW	P1PA03540-B0XX/6	CUST.	
07	Nov.12, 08	K.Okada	T.Anzai	I.Fujioka	Refer to Revision Record on page 2.	No.			
06	Mar.10, 08	K.Okada	T.Anzai	I.Fujioka	Refer to Revision Record on page 2.				
Rev.	DATE	DESIGN	CHECK	APPR.	DESCRIPTION	PFU LIMITED		Page	153 / 257
Design	July 27, 2007	K.Okada	CHECK	K.Okada		APPR.	T.Anzai		

5-12-10 Joint PCA **fi-6240/fi-6230**

NOTICE

Refer to Section 3-39 for the part number of the replacement part.
 - Refer to Appendix for the specification of the screws.

<Removal>

Remove Flatbed.

Referring to Section 5-7 “Removing Flatbed,” remove the Flatbed.

1. Remove Document Cover.

(1) Referring to Section 5-12-9 “Document Cover,” remove the Document Cover.

2. Remove FB Top Cover.

(2) Referring to step (2) of Section 5-12-1 “FB Top Cover,” remove the FB Top Cover.

3. Remove OPT Box Unit.

(3) Referring to steps (3) ~ (4) of Section 5-12-4 “OPT Box Unit,” remove the OPT Box Unit.

4. Remove Joint PCA.

(4) - Remove the screw A (square below) on the Joint PCA, and then remove the Joint PCA.
 - Disconnect two cables (circles below) of the Joint PCA.

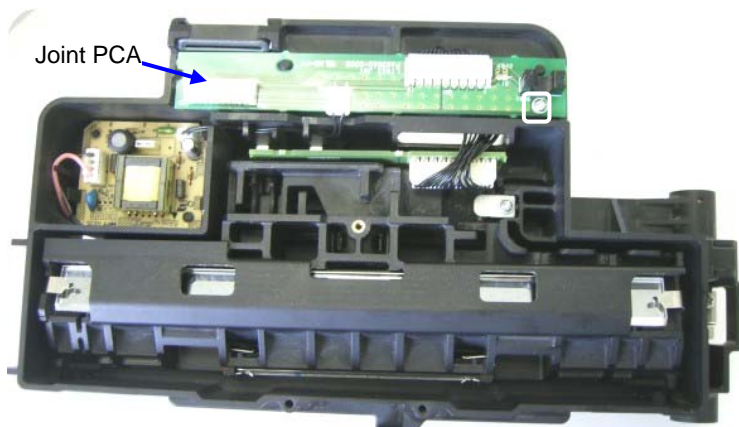

						TITLE	fi-6140/fi-6240/fi-6130/fi-6230/fi-614PR Maintenance Manual		
08	July 27, 09	K.Okada	A.Miyoshi	I.Fujioka	Refer to Revision Record on page 2.	DRAW No.	P1PA03540-B0XX/6	CUST.	
07	Nov.12, 08	K.Okada	T.Anzai	I.Fujioka	Refer to Revision Record on page 2.				
06	Mar.10, 08	K.Okada	T.Anzai	I.Fujioka	Refer to Revision Record on page 2.				
Rev.	DATE	DESIGN	CHECK	APPR.	DESCRIPTION	PFU LIMITED		Page	154 / 257
Design	July 27, 2007	K.Okada	CHECK	K.Okada		APPR.	T.Anzai		

<Installation>

Follow the removing procedure in reverse.

- Note: Perform the following adjustments after replacing the parts.
- Referring to Section 6-1-3 "Maintenance Mode #2," adjust the magnification.
 - Referring to Section 6-1-4 "Maintenance Mode #3," adjust the offset.
 - Referring to Section 6-1-5 "Maintenance Mode #4," adjust the white level.

						TITLE	fi-6140/fi-6240/fi-6130/fi-6230/fi-614PR Maintenance Manual		
08	July 27, 09	K.Okada	A.Miyoshi	I.Fujioka	Refer to Revision Record on page 2.	DRAW No.	P1PA03540-B0XX/6	CUST.	
07	Nov.12, 08	K.Okada	T.Anzai	I.Fujioka	Refer to Revision Record on page 2.				
06	Mar.10, 08	K.Okada	T.Anzai	I.Fujioka	Refer to Revision Record on page 2.				
Rev.	DATE	DESIGN	CHECK	APPR.	DESCRIPTION	PFU LIMITED		Page	155 / 257
Design	July 27, 2007	K.Okada	CHECK	K.Okada		APPR.	T.Anzai		

Chapter 6 Adjustment/Settings

6-1 Maintenance mode

The scanner supports built-in Maintenance mode that allows service engineers to check scanner's performance and settings. This section gives the description of Maintenance mode.

Note on Maintenance Mode

08

If you want to perform **“White level adjustment”** for Flatbed with a **“Black document holding pad”** installed onto the scanner, replace it with the standard **“White document holding pad”** before starting the adjustment.

If you cannot install the standard **“White document holding pad”**, pile up three white reference sheets and close the **“Black document holding pad”**, and then start adjustment.

*** If White level adjustment is performed with a “Black document holding pad” installed, the correct offset may not be acquired which results in abnormal image (the image is too bright).**

6-1-1 Activating the Maintenance mode

(1) How to activate the Maintenance mode

Open the ADF and press the power button once while holding down the **Scan/Stop** button. Keep holding the **Scan/Stop** button down until Screen T04 is displayed. This will put the scanner into Maintenance mode. While in Maintenance mode, the scanner interface is off-line.

The following display appears during power up processing in Maintenance mode.

Screen T01

Function No. Display	Power LED	Scanner status
	ON	Initial processing in Maintenance mode

When Maintenance mode is activated normally after the initial processing, the following display appears.

Screen T04

Function No. Display	Power LED	Scanner status
	ON	Maintenance mode #1 selected

(2) Test/adjustment items of the Maintenance mode

The following lists test/adjustment items #1 ~ #7 that are supported by the scanner.

Mode 1: Paper transportation / Sensor / Background changeover test

Mode 2: Main scanning/Sub-scanning magnification adjustment

Mode 3: Offset adjustment

Mode 4: White level adjustment

Mode 5: Consumables counter display and reset

Mode 6: Miscellaneous information display

Mode 7: EEPROM data restore

Rev.	DATE	DESIGN	CHECK	APPR.	DESCRIPTION	TITLE	fi-6140/fi-6240/fi-6130/fi-6230/fi-614PR	
08	July 27, 09	K.Okada	A.Miyoshi	I.Fujioka	Refer to Revision Record on page 2.	DRAW No.	Maintenance Manual	
07	Nov.12, 08	K.Okada	T.Anzai	I.Fujioka	Refer to Revision Record on page 2.		P1PA03540-B0XX/6	CUST.
06	Mar.10, 08	K.Okada	T.Anzai	I.Fujioka	Refer to Revision Record on page 2.			
Design	July 27, 2007	K.Okada	CHECK	K.Okada		APPR.	T.Anzai	PFU LIMITED
						Page	156 / 257	

(3) Changing Maintenance mode

To change Maintenance modes (#1 ~ #8), press the **Function** button on the activation screen for Maintenance mode. The display changes as follows. Mode #1 is the default mode.

Maintenance mode No.	Display			Maintenance mode	Related section
	Function No. Display	Power LED	Status transition		
#1		ON		Paper transportation / Sensor / Background changeover test	6-1-2
#2		ON		Main-scanning/ Sub-scanning magnification adjustment	6-1-3
#3		ON		Offset adjustment	6-1-4
#4		ON		White level adjustment	6-1-5
#5		ON		Consumables counter display and reset	6-1-6
#6		ON		Miscellaneous information display	6-1-7
#7		ON		EEPROM data restore	6-1-8
#8		ON		(Reserved) * Pressing the Function button returns to #1.	

(4) Starting the Maintenance mode

Select one Maintenance mode and press **Scan**. The scanner activates the selected Maintenance mode.

						TITLE	fi-6140/fi-6240/fi-6130/fi-6230/fi-614PR		
08	July 27, 09	K.Okada	A.Miyoshi	I.Fujioka	Refer to Revision Record on page 2.		Maintenance Manual		
07	Nov.12, 08	K.Okada	T.Anzai	I.Fujioka	Refer to Revision Record on page 2.	DRAW No.	P1PA03540-B0XX/6		CUST.
06	Mar.10, 08	K.Okada	T.Anzai	I.Fujioka	Refer to Revision Record on page 2.				
Rev.	DATE	DESIGN	CHECK	APPR.	DESCRIPTION	PFU LIMITED		Page	157 / 257
Design	July 27, 2007	K.Okada	CHECK	K.Okada		APPR.	T.Anzai		

6-1-2 Maintenance mode #1: Paper feeding / Sensor / Background changeover test

This mode tests the ADF/FB paper feeding operation at the selected speed, checks each status (ON/OFF) of the ADF sensors, and tests background changeover.

[How to start]

- (1) From screen T04, press the **Function** (Δ or ∇) button to select **Function No. 1** (Maintenance mode #1) and press the **Scan/Stop** button. The selection screen for scanning speed/sensor/Background changeover test appears. A number is shown on the Function No. Display indicating the selected scanning speed or test mode as follows.

Function No. Display	Scanning speed/test mode	Remarks
0	Monochrome 600 dpi	Default
1	Monochrome 300 dpi	
2	Monochrome 240 dpi	
3	Monochrome 200 dpi	
4	Monochrome 100 dpi	
5	Monochrome 150 dpi	
6	Monochrome 400 dpi	
7	Sensor test	
8	Background changeover test	

<Paper feeding test>

- (2) Select a scanning speed from 0 to 6 (this varies depending on the scanning resolution) from 0 ~ 6 by pressing the **Function** button.

When the Imprinter option is NOT connected:

- (3) To test the continuous feeding operation, press the **Scan/Stop** button. The ADF operation is started if any paper on the ADF paper chute (Chute unit) (Hopper empty sensor = Sensor EMP ON).
To test the one-sheet feeding operation, while pressing the **Send to** button, press the **Scan/Stop** button, which switches to the one-sheet feeding operation mode. Go to step (5).

When the Imprinter option is connected:

- (3) To test the continuous feeding operation, press the **Scan/Stop** button. The function number display requires selecting whether imprinting is necessary or not.
To test the one-sheet feeding operation, while pressing the **Send to** button, press the **Scan/Stop** button, which switches to the one-sheet feeding operation mode. The function number display requires to select whether imprinting is necessary or not. When the display changed, press the **Send to** button.

Function number display	Mode	Remarks
—	NO imprinting	Default (Screen T11)
P	Imprinting	Screen T12

• Test print specification

Printing position: The test pattern below are printed out starting at 5mm from the leading edge of the paper.

Test pattern 1: ABCDEFGHIJKLMNOPQRSTUVWXYZ[¥]^_` (32 characters, horizontal)

Test pattern 2: abcdefghijklmnopqrstuvwxyz{|}~ (31 characters, horizontal)

Test pattern 3: !"#\$%&'()*+,-./0123456789:;<=>?@ (32 characters, horizontal)

Test pattern 4: ABCDEFGHIJKLMNOPQRSTUVWXYZ[¥]^_` (32 characters, vertical)

Test pattern 5: abcdefghijklmnopqrstuvwxyz{|}~ (31 characters, vertical)

Test pattern 6: !"#\$%&'()*+,-./0123456789:;<=>?@ (32 characters, vertical)

The test pattern above is postfixed with an 8-digit-number. A total of 40 characters are printed in pattern 1, 3, 4 or 6. A total of 39 characters are printed in pattern 2 or 5.

Printing is repeated in the order of pattern 1→2→3→4→5→6→1→2→3...

The numbering data portion is incremented by one from "00000000."

Rev.	DATE	DESIGN	CHECK	APPR.	DESCRIPTION	TITLE	P1PA03540-B0XX/6	
08	July 27, 09	K.Okada	A.Miyoshi	I.Fujioka	Refer to Revision Record on page 2.	fi-6140/fi-6240/fi-6130/fi-6230/fi-614PR Maintenance Manual	CUST.	
07	Nov.12, 08	K.Okada	T.Anzai	I.Fujioka	Refer to Revision Record on page 2.		CUST.	
06	Mar.10, 08	K.Okada	T.Anzai	I.Fujioka	Refer to Revision Record on page 2.		CUST.	
Design	July 27, 2007	K.Okada	CHECK	K.Okada	APPR.	T.Anzai	PFU LIMITED	Page 158 / 257

(4) Select whether imprinting is necessary or not by pressing the **Function** button.

Screen T11

Function No. display	Scanner status
	“-” lights without blinking. NO imprinting (default)

<Available buttons at Screen T11 and T12>

Function button: Switches between Screens T11 and T12 every press.

Send to button: Terminates this mode and returns to Screen T04.

Screen T12

Function No. display	Scanner status
	“P” lights without blinking. Imprinting

(5) Press the **Scan/Stop** button. The ADF operation is started if there is any paper on the ADF paper chute (Chuter unit) (Sensor EMP: ON). In case of fi-6240/fi-6230, FB operation is started if there is no paper on the ADF paper chute (Chuter unit).

<Sensor test>

(2) By pressing the **Scan/Stop** button while “7” is shown on the display, the scanner enters Sensor test mode.

The following table shows how the sensor status is displayed while the sensor test is in progress.

Refer to Section 6-2 “Saving EEPROM data” for the sensor positions of the ADF.

Function No. Display	Description *2	Display
	1: indicates Imprinter document detection sensor status	Illuminates when the sensor is ON (Paper is detected)
	2: indicates Empty sensor (Sensor EMP) status	Illuminates when the sensor is ON (Paper is detected)
	3: indicates PICK sensor status	Illuminates when the sensor is ON (Paper is detected)
	4: indicates TOP sensor status	Illuminates when the sensor is ON (Paper is detected)
	5: indicates Cover Open Sensor (Switch) status	Illuminates when the sensor is OFF (Cover is open) *1
	6: indicates Imprinter printing section status (open/close)	Illuminates when the sensor is OFF (Printing section is open)
	7: indicates Multi feed sensor (US Sensor) status	Illuminates when the sensor is ON (Multifeed is detected)
	8: Indicates Paper Protection function status	Illuminates when the sensor is ON (Encoder rotation is detected) (Blinks when Encoder is rotating.)

*1: This sensor test should be conducted by opening/closing the ADF cover. If the Cover open sensor is pressed by anything while the ADF cover is open, the Multi feed sensor (US Sensor) turns ON, causing position “7” to light as well.

*2: The confirmation of US sensor is available only when the document is fed by pressing the **Function** button as described below. You cannot confirm US sensor by just inserting document (no feeding) between US sensors.

(3) During the sensor test, you can check the sensor status (ON/OFF) when the document passes through the ADF by the following procedure:

1. Press the **Function** button. The ADF Motor starts to rotate.
2. Set the document into the ADF paper chute (Chute unit).

<Background changeover test>

(2) While “8” is shown on the display, close the cover if it is opened. Pressing the **Scan/Stop** button starts Background changeover test (white ⇔ black). The operation stops automatically after changeover 20 times between black and white.

[How to end]

Press the **Send to** button. The test stops and the Maintenance mode selection Screen T04 appears. The ADF continuous feeding operation is also terminated when no more paper on the ADF paper chute (Chute unit).

						TITLE	fi-6140/fi-6240/fi-6130/fi-6230/fi-614PR Maintenance Manual		
08	July 27, 09	K.Okada	A.Miyoshi	I.Fujioka	Refer to Revision Record on page 2.	DRAW No.	P1PA03540-B0XX/6	CUST.	
07	Nov.12, 08	K.Okada	T.Anzai	I.Fujioka	Refer to Revision Record on page 2.				
06	Mar.10, 08	K.Okada	T.Anzai	I.Fujioka	Refer to Revision Record on page 2.				
Rev.	DATE	DESIGN	CHECK	APPR.	DESCRIPTION	PFU LIMITED		Page	159 / 257
Design	July 27, 2007	K.Okada	CHECK	K.Okada		APPR.	T.Anzai		

6-1-3 Maintenance mode #2: Main scanning / Sub-scanning magnification adjustment

In this mode, the magnification correction values for main/sub-scanning are automatically calculated to satisfy the following adjustment value:

Adjustment value

Main scanning: Within $\pm 1.0\%$

Sub scanning: Within $\pm 1.0\%$ (Without stop and start during scanning)

: Within $\pm 2.0\%$ (With stop and start during scanning)

NOTICE

Before this adjustment, please prepare the Test sheet described in Figure 6-1-3.

If Main-scanning magnification (ADF front or back, or FB) is adjusted, then run Offset adjustment (ADF front or back, or FB) described in Section 6-1-4.

[How to start]

- (1) From screen T04, Press the **Function** (Δ or ∇) button to select  (Maintenance mode #2) and press the **Scan/Stop** button. A number is shown on the Function No. Display indicating the magnification to be adjusted as follows:

Function No. Display	Magnification to be adjusted	Remarks
0	ADF sub- scanning magnification adjustment	Default
1	ADF main scanning magnification adjustment (front)	
2	ADF main scanning magnification adjustment (back)	
3	FB sub-scanning magnification adjustment	FB models (fi-6240/fi-6230) only
4	FB main scanning magnification adjustment	FB models (fi-6240/fi-6230) only

- (2) Select the magnification you want to change by pressing **Function** button.
- (3) For the ADF adjustment, set the Test sheet on the ADF paper chute (Chute Unit), and adjust the side guide to the width of the test sheet.
For the FB adjustment, set the Test sheet on the Document bed to be aligned with the reference point (left of the Document bed, front edge), and remove the Document Cover. Avoid working near light source such as fluorescent lamp.
- (4) Press **Scan/Stop** button to start the adjustment.

[How to end]

Press **Send to** button during operation. The operation stops and the Maintenance mode selection screen (T04) appears.

						TITLE	fi-6140/fi-6240/fi-6130/fi-6230/fi-614PR Maintenance Manual		
08	July 27, 09	K.Okada	A.Miyoshi	I.Fujioka	Refer to Revision Record on page 2.	DRAW	P1PA03540-B0XX/6	CUST.	
07	Nov.12, 08	K.Okada	T.Anzai	I.Fujioka	Refer to Revision Record on page 2.	No.			
06	Mar.10, 08	K.Okada	T.Anzai	I.Fujioka	Refer to Revision Record on page 2.				
Rev.	DATE	DESIGN	CHECK	APPR.	DESCRIPTION	PFU LIMITED		Page	160 / 257
Design	July 27, 2007	K.Okada	CHECK	K.Okada		APPR.	T.Anzai		

[Display after adjustment]

After the magnification adjustment, the following display appears depending on its terminated status.

(1) When the magnification adjustment is terminated normally

Screen T21

Function No. Display	Scanner status
	Displays "o" (lower half) without blinking.

<Available buttons at screen T21>

Function button: Displays screen T22 to write the correction value into EEPROM.

Send to button: Terminates this mode and returns to screen T04.

Screen T22

Function No. Display	Scanner status
	"o" (lower half) blinks.

<Available buttons at screen T22>

Scan/Stop + **Function** button: Starts writing the magnification correction value into EEPROM. During writing operation, screen T23 displayed, and when it finishes, screen T24 appears.

Send to button: Terminates this mode and returns to screen T04.

Screen T23

Function No. Display	Scanner status
	"L" lights without blinking.

Note: While screen T23 is displayed, no button can function.

Screen T24

Function No. Display	Scanner status
	"o" (upper half) lights without blinking.

<Available buttons at screen T24>

Send to button: Terminates this mode and returns to screen T04.

						TITLE	fi-6140/fi-6240/fi-6130/fi-6230/fi-614PR Maintenance Manual		
08	July 27, 09	K.Okada	A.Miyoshi	I.Fujioka	Refer to Revision Record on page 2.	DRAW No.	P1PA03540-B0XX/6	CUST.	
07	Nov.12, 08	K.Okada	T.Anzai	I.Fujioka	Refer to Revision Record on page 2.				
06	Mar.10, 08	K.Okada	T.Anzai	I.Fujioka	Refer to Revision Record on page 2.				
Rev.	DATE	DESIGN	CHECK	APPR.	DESCRIPTION	PFU LIMITED		Page	161 / 257
Design	July 27, 2007	K.Okada	CHECK	K.Okada		APPR.	T.Anzai		

(2) When the magnification adjustment is terminated abnormally

Screen T25

Function No. Display	Scanner status
	Displays "c" without blinking.

Note: The major reason of abnormal termination is incorrect setting of the test sheet. Set the test sheet correctly and try the magnification adjustment again.

<Available buttons at screen T25>

Function button: Displays error information (screen T26)

Send to button: Terminates this mode and returns to screen T04.

Screen T26

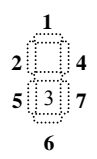
Function No. Display	Description	Adjustment mode (*1)				Countermeasure when abnormal termination frequently occurs
		0	1,2	3	4	
	1: cannot detect the leading edge of the document	√		√		Conduct necessary operation by referring to step (2) and later in Section 4-3-7 or Section 4-3-10.
	2: cannot detect the left edge of the document		√		√	
	4: cannot detect the right edge of the document		√		√	
	5: Excessive skew A		√	√		
	6: cannot detect the trailing edge of the document	√		√		
	7: Excessive skew B		√		√	

- (*1) 0 : ADF sub-scanning magnification adjustment
- 1,2: ADF front/back main scanning magnification adjustment
- 3: FB sub-scanning magnification adjustment
- 4: FB main scanning magnification adjustment

Skew A and B are calculated as follows:

Skew A = a - b
 Skew B = c - d

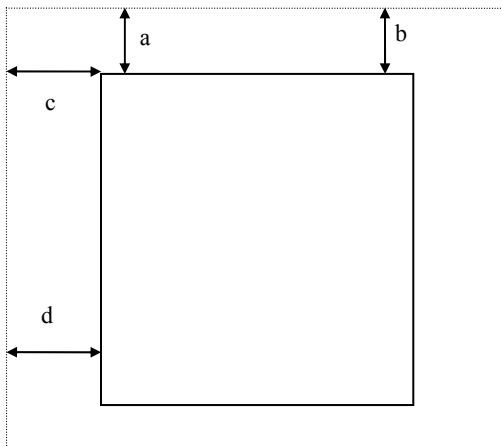

<Available button at screen T26>

Send to button: Terminates this mode and returns to screen T04.

						TITLE	fi-6140/fi-6240/fi-6130/fi-6230/fi-614PR		
08	July 27, 09	K.Okada	A.Miyoshi	I.Fujioka	Refer to Revision Record on page 2.		Maintenance Manual		
07	Nov.12, 08	K.Okada	T.Anzai	I.Fujioka	Refer to Revision Record on page 2.	DRAW No.	P1PA03540-B0XX/6		CUST.
06	Mar.10, 08	K.Okada	T.Anzai	I.Fujioka	Refer to Revision Record on page 2.				
Rev.	DATE	DESIGN	CHECK	APPR.	DESCRIPTION	PFU LIMITED		Page	162 / 257
Design	July 27, 2007	K.Okada	CHECK	K.Okada		APPR.	T.Anzai		

[Test sheet]

Use the test sheet for the magnification/offset adjustment that meets the following specification.

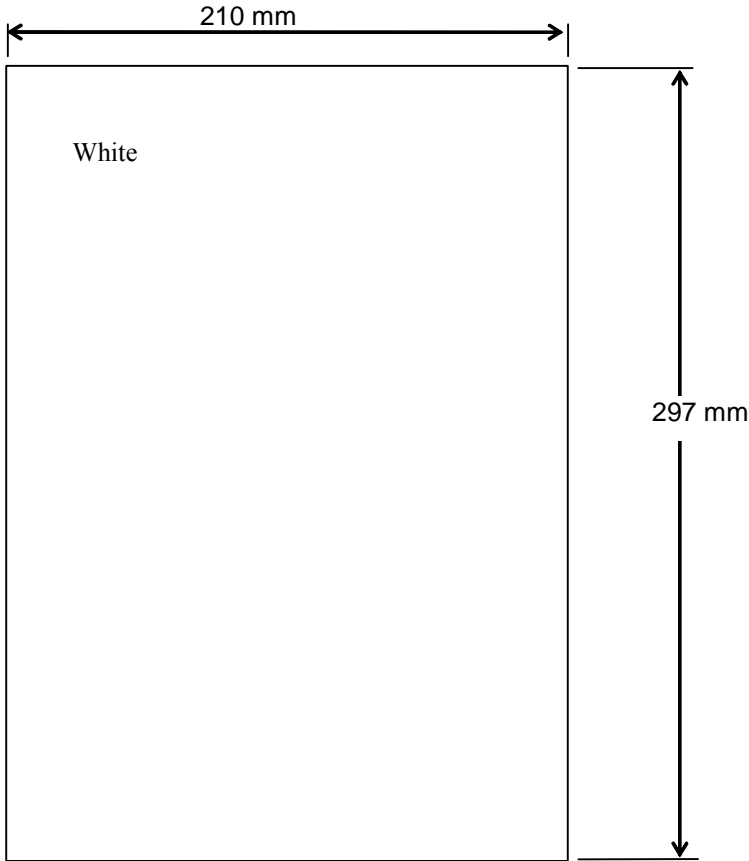

Use Normal A4 office paper.
(White level adjustment sheet can also be used.)

Figure 6-1-3 Test sheet for the magnification/offset adjustment

						TITLE	fi-6140/fi-6240/fi-6130/fi-6230/fi-614PR Maintenance Manual		
08	July 27, 09	K.Okada	A.Miyoshi	I.Fujioka	Refer to Revision Record on page 2.	DRAW No.	P1PA03540-B0XX/6	CUST.	
07	Nov.12, 08	K.Okada	T.Anzai	I.Fujioka	Refer to Revision Record on page 2.				
06	Mar.10, 08	K.Okada	T.Anzai	I.Fujioka	Refer to Revision Record on page 2.				
Rev.	DATE	DESIGN	CHECK	APPR.	DESCRIPTION	PFU LIMITED		Page	163 / 257
Design	July 27, 2007	K.Okada	CHECK	K.Okada		APPR.	T.Anzai		

6-1-4 Maintenance mode #3: Offset adjustment

In this mode, the offset correction values for main/sub scanning are automatically calculated to satisfy the following offset values:

Offset value

Main scanning: The largest offset of A6 or larger size of document shall be: ± 24 dot

Sub-scanning: The largest offset of A6 or larger size of document shall be: ± 33 dot

NOTICE

Before this adjustment, please prepare the Test sheet described in Figure 6-1-3.

Also, before adjusting offset (ADF front or back, or FB), run Main-scanning magnification adjustment (ADF front or back, or FB) by referring to Section 6-1-3.

[How to start]

- (1) From screen T04, Press the **Function** (Δ or ∇) button to select  (Maintenance mode #3) and press the **Scan/Stop** button. A number is shown on the Function No. Display indicating the location of the offset to be adjusted.

Function No. Display	Offset to be adjusted	Remarks
0	ADF front	Default
1	ADF back	
2	FB	FB models (fi-6240/fi-6230) only

- (2) Change the selection by pressing **Function** button.

- (3) For the ADF adjustment, set the test sheet (see Figure 6-1-3) on the ADF paper chute (Chute Unit), and adjust the side guide to the width of the test sheet.

For the FB adjustment, set the test sheet (see Figure 6-1-3) on the Document bed to be aligned with the reference point (left of the Document bed, front edge), and remove the Document Cover. Avoid working near light source such as fluorescent lamp.

- (4) Press **Scan/Stop** button to start the adjustment operation.

[How to end]

Press **Send to** button during operation. The operation stops and the Maintenance mode selection screen (T04) appears.

						TITLE	fi-6140/fi-6240/fi-6130/fi-6230/fi-614PR Maintenance Manual		
08	July 27, 09	K.Okada	A.Miyoshi	I.Fujioka	Refer to Revision Record on page 2.	DRAW No.	P1PA03540-B0XX/6	CUST.	
07	Nov.12, 08	K.Okada	T.Anzai	I.Fujioka	Refer to Revision Record on page 2.				
06	Mar.10, 08	K.Okada	T.Anzai	I.Fujioka	Refer to Revision Record on page 2.				
Rev.	DATE	DESIGN	CHECK	APPR.	DESCRIPTION	PFU LIMITED		Page	164 / 257
Design	July 27, 2007	K.Okada	CHECK	K.Okada		APPR.	T.Anzai		

[Display after adjustment]

After the offset adjustment, the following display appears depending on its terminated status.

(1) When the offset adjustment is terminated normally

Screen T31

Function No. Display	Scanner status
	Displays "o" without blinking. The adjustment has terminated normally.

<Available buttons at screen T31>

Function button: Displays screen T32 to write the correction value into EEPROM.

Send to button: Terminates this mode and return to screen T04.

Screen T32

Function No. Display	Scanner status
	"o" (lower half) blinks. Confirming whether the correction value shall be written in EEPROM or not.

<Available buttons at screen T32>

Scan/Stop + **Function** button: Start writing the offset correction value into EEPROM. During writing operation, screen T33 displayed, and when it finishes, screen T34 appears.

Send to button: Terminates this mode and returns to screen T04.

Screen T33

Function No. Display	Scanner status
	"L" lights without blinking. Correction value is being written in EEPROM.

Note: While screen T33 is displayed, no button can function.

Screen T34

Function No. Display	Scanner status
	"o" (upper half) lights without blinking. The value has been written normally.

<Available buttons at screen T34>

Send to button: Terminates this mode and returns to screen T04

						TITLE	fi-6140/fi-6240/fi-6130/fi-6230/fi-614PR Maintenance Manual		
08	July 27, 09	K.Okada	A.Miyoshi	I.Fujioka	Refer to Revision Record on page 2.	DRAW No.	P1PA03540-B0XX/6	CUST.	
07	Nov.12, 08	K.Okada	T.Anzai	I.Fujioka	Refer to Revision Record on page 2.				
06	Mar.10, 08	K.Okada	T.Anzai	I.Fujioka	Refer to Revision Record on page 2.				
Rev.	DATE	DESIGN	CHECK	APPR.	DESCRIPTION	PFU LIMITED		Page	165 / 257
Design	July 27, 2007	K.Okada	CHECK	K.Okada		APPR.	T.Anzai		

(2) When the offset adjustment is terminated abnormally

Screen T35

Function No. Display	Scanner status
	Displays "c" without blinking. The adjustment has terminated abnormally.

Note: The major reason of abnormal termination is incorrect setting of the test sheet. Set the test sheet correctly and try the magnification adjustment again.

<Available buttons at screen T35>

Function button: Displays error information (screen T36)

Send to button: Terminates this mode and returns to screen T04.

Screen T36

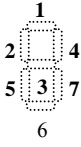
Function No. Display	Description	Adjustment mode (*1)			Countermeasure when abnormal termination frequently occurs
		0	1	2	
	1: cannot detect the leading edge of the document (black detection failed)	√	√	√	Conduct necessary operation by referring to step (2) and later in Section 4-3-6 or Section 4-3-9.
	2: cannot detect the left edge of the document (black detection failed)	√	√	√	
	3: cannot detect the leading edge of the document (white detection failed)	√	√	√	
	4: Excessive skew A	√	√	√	
	5: cannot detect the left edge of the document (white detection failed)	√	√	√	
	6: Excessive skew B	√	√	√	
	7: Excessive skew B	√	√	√	

(*1) 0: ADF front 1: ADF back 2: FB

Skew A and B are calculated by the following expression.

$$\text{Skew A} = a - b$$

$$\text{Skew B} = c - d$$

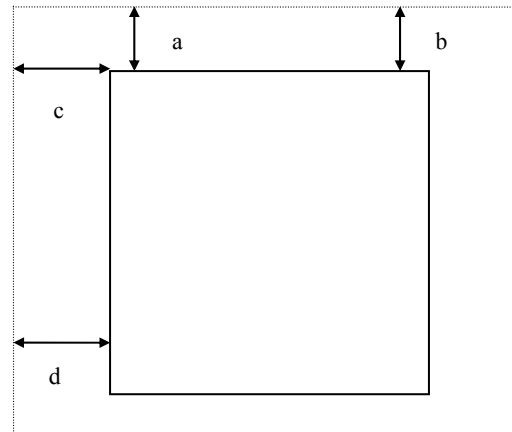

<Available buttons at screen T36>

Send to button: Terminates this mode and returns to screen T04.

[Test sheet]

Use the same sheet as used for the magnification adjustment. See Figure 6-1-3.

						TITLE	fi-6140/fi-6240/fi-6130/fi-6230/fi-614PR Maintenance Manual		
08	July 27, 09	K.Okada	A.Miyoshi	I.Fujioka	Refer to Revision Record on page 2.	DRAW No.	P1PA03540-B0XX/6	CUST.	
07	Nov.12, 08	K.Okada	T.Anzai	I.Fujioka	Refer to Revision Record on page 2.				
06	Mar.10, 08	K.Okada	T.Anzai	I.Fujioka	Refer to Revision Record on page 2.				
Rev.	DATE	DESIGN	CHECK	APPR.	DESCRIPTION	PFU LIMITED		Page	166 / 257
Design	July 27, 2007	K.Okada	CHECK	K.Okada		APPR.	T.Anzai		

[Display after adjustment]

After the white level adjustment, the following display appears depending on its terminated status.

(1) When the white level adjustment is terminated normally

Screen T41

Function No. Display	Scanner status
	Displays "o" without blinking. The adjustment has terminated normally.

<Available buttons at screen T41>

Function button: Displays screen T42 to write the white level correction value into EEPROM.

Send to button: Terminates this mode and returns to screen T04.

Screen T42

Function No. Display	Scanner status
	"o" (lower half) blinks. Confirming whether the correction value shall be written in EEPROM or not.

<Available buttons at screen T42>

Scan/Stop + **Function** button: Start writing the white level correction value into EEPROM. During writing operation, screen T43 displayed, and when it finishes, screen T44 appears

Send to button: Terminates this mode and returns to screen T04.

Screen T43

Function No. Display	Scanner status
	"L" lights without blinking. Correction value is being written in EEPROM.

Note: While screen T43 is displayed, no button can function.

Screen T44

Function No. Display	Scanner status
	"o" (upper half) lights without blinking. The value has written normally.

<Available buttons at screen T44>

Send to button: Terminates this mode and returns to screen T04.

						TITLE	fi-6140/fi-6240/fi-6130/fi-6230/fi-614PR Maintenance Manual		
08	July 27, 09	K.Okada	A.Miyoshi	I.Fujioka	Refer to Revision Record on page 2.	DRAW No.	P1PA03540-B0XX/6	CUST.	
07	Nov.12, 08	K.Okada	T.Anzai	I.Fujioka	Refer to Revision Record on page 2.				
06	Mar.10, 08	K.Okada	T.Anzai	I.Fujioka	Refer to Revision Record on page 2.				
Rev.	DATE	DESIGN	CHECK	APPR.	DESCRIPTION	PFU LIMITED		Page	168 / 257
Design	July 27, 2007	K.Okada	CHECK	K.Okada		APPR.	T.Anzai		

(2) When the white level adjustment is terminated abnormally

Screen T45

Function No. Display	Scanner status
	Displays "c". The adjustment has terminated abnormally.

Note: The major reason of abnormal termination is incorrect setting of the test sheet. Set the test sheet correctly and try the magnification adjustment again.

<Available buttons at screen T45>

Function button: Displays error information (screen T46)

Send to button: Terminates this mode and returns to screen T04.

Screen T46

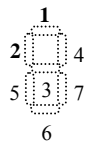
Function No. Display	Description	Countermeasure when abnormal termination frequently occurs
	1: media error The tested sheet may not be the specified one. Check the test sheet. 2: No paper	It seems Lamp or Optical Unit is faulty. Replace defective parts.

<Available buttons at screen T46>

Send to button: Terminates this mode and return to screen T04.

						TITLE	fi-6140/fi-6240/fi-6130/fi-6230/fi-614PR Maintenance Manual		
08	July 27, 09	K.Okada	A.Miyoshi	I.Fujioka	Refer to Revision Record on page 2.	DRAW No.	P1PA03540-B0XX/6	CUST.	
07	Nov.12, 08	K.Okada	T.Anzai	I.Fujioka	Refer to Revision Record on page 2.				
06	Mar.10, 08	K.Okada	T.Anzai	I.Fujioka	Refer to Revision Record on page 2.				
Rev.	DATE	DESIGN	CHECK	APPR.	DESCRIPTION	PFU LIMITED		Page	169 / 257
Design	July 27, 2007	K.Okada	CHECK	K.Okada		APPR.	T.Anzai		

6-1-6 Maintenance mode #5: Consumable counter display and reset

In this mode, the following consumable counter is displayed and reset:

- ADF Pick roller counter (Abrasion counter for Pick roller)
- ADF Brake roller counter (Abrasion counter for Brake roller)
- Remaining amount of ink dot
- Imprinter consumables (Abrasion counter for Print head)

[How to operate]

- (1) From screen T04, press the **Function** (Δ or ∇) button to select **0** (Maintenance mode #5) and press the **Scan/Stop** button. A number is shown on the Function No. Display indicating the counters as follows.

Function No. Display	White level to be adjusted	Remarks
0	ADF Pick roller counter (Abrasion counter for Pick roller)	Default
1	ADF Brake roller counter (Abrasion counter for Brake roller)	
2	(Reserved)	
3	Remaining amount of ink dot	Displayed only when the Imprinter is installed.
4	Imprinter consumables (Abrasion counter for Print head)	

- (2) Change the selection by pressing **Function** button.

- (3) The counter is displayed as follows when pressing **Scan/Stop** button.

Counter	Display
ADF Pick roller counter (Abrasion counter for Pick roller)	The counter displays 8 digits in total, 1 number at a time, from left digit to right digit. (If the counter has not reached 8 digits yet, 0 is added to blank digits.) The symbol “-” is displayed before the first number, indicating the counter display starts. The counter increments by 10. e.g. When the counter is “16,245”, “-00016245” is displayed in the following order: “-” → “0” → “0” → “0” → “1” → “6” → “2” → “4” → “0” “-“ indicates a starting mark.
ADF Brake roller counter (Abrasion counter for Brake roller)	See “Pick roller counter” above.
Remaining amount of ink dot	The counter displays 3 digits between 100 to 0 in percentage (%). 100% is the initial status. Displayed remaining amount of ink is just a target as it depends on the condition in which it is used. e.g.: When the remaining amount is 58% “-” → “0” → “5” → “8” “-“ indicates a starting mark. When the Imprinter is not connected, only “-“ is displayed.
Imprinter consumables (Abrasion counter for Print head)	See “Pick counter” above.

						TITLE	fi-6140/fi-6240/fi-6130/fi-6230/fi-614PR Maintenance Manual		
08	July 27, 09	K.Okada	A.Miyoshi	I.Fujioka	Refer to Revision Record on page 2.	DRAW No.	P1PA03540-B0XX/6	CUST.	
07	Nov.12, 08	K.Okada	T.Anzai	I.Fujioka	Refer to Revision Record on page 2.				
06	Mar.10, 08	K.Okada	T.Anzai	I.Fujioka	Refer to Revision Record on page 2.				
Rev.	DATE	DESIGN	CHECK	APPR.	DESCRIPTION	PFU LIMITED		Page	170 / 257
Design	July 27, 2007	K.Okada	CHECK	K.Okada		APPR.	T.Anzai		

(4) The following buttons are available during counter display.

Function button: Displays screen T51 to reset the counter.

Send to button: Terminates this mode and returns to screen T04.

Screen T51

Function No. Display	Scanner status
	“o” (lower half) blinks. Confirming whether the counter shall be reset or not.

<Available buttons at screen T51>

Scan/Stop + **Function** button: Starts resetting the displayed counter value to 0. During writing operation, screen T52 displayed, and when it finishes, screen T53 appears.

Note: After reset, the counter value below 500 remains without being reset and that value will be the initial value of the internal counter, but this is not an error.

eg.) When “52,168” is reset, 168 remains and the internal counter will start counting from 168, while Function No. Display shows 0.

Send to button: Terminates this mode and returns to screen T04.

Screen T52

Function No. Display	Scanner status
	“L” lights without blinking. The counter is being reset.

Note: While screen T52 is displayed, no button can function.

Screen T53

Function No. Display	Scanner status
	“o” (upper half) lights without blinking. Counter reset has done.

<Available buttons at screen T53>

Send to button: Terminates this mode and returns to screen T04.

						TITLE	fi-6140/fi-6240/fi-6130/fi-6230/fi-614PR Maintenance Manual		
08	July 27, 09	K.Okada	A.Miyoshi	I.Fujioka	Refer to Revision Record on page 2.	DRAW No.	P1PA03540-B0XX/6	CUST.	
07	Nov.12, 08	K.Okada	T.Anzai	I.Fujioka	Refer to Revision Record on page 2.				
06	Mar.10, 08	K.Okada	T.Anzai	I.Fujioka	Refer to Revision Record on page 2.				
Rev.	DATE	DESIGN	CHECK	APPR.	DESCRIPTION	PFU LIMITED		Page	171 / 257
Design	July 27, 2007	K.Okada	CHECK	K.Okada		APPR.	T.Anzai		

6-1-7 Maintenance mode #6: Miscellaneous information display

In this mode, the following information counter is displayed:

- Firmware version number
- Starting date of the scanner *
- The accumulated number of paper that have been scanned by ADF
- The accumulated number of paper that have been scanned by FB (fi-6240/fi-6230 only)

*: This indicates the date when the scanner is activated by the driver first. This information is only available if the driver supports this function.

[How to start]

(1) Selects Maintenance mode #6 in screen T04 and press **Scan/Stop** button. A number appears on the Function No. Display indicating the information.

Function No. Display	Display	Remarks
0	Firmware version	Default
1	Starting date of the scanner	
2	The accumulated number of paper scanned by ADF	
3	The accumulated number of paper scanned by FB	FB models (fi-6240/fi-6230) only

(2) Change the selection by pressing **Function** button.

(3) The information is displayed as follows when pressing **Scan/Stop** button.

Information	Display
Firmware version number	<p>The firmware version number is displayed in 4 digits from left digits to right digits, following the symbol “-”.</p> <p>Without Imprinter installed (example): eg. When the scanner version is “A00” (*1), “A” is converted to “01” (*2), so the scanner displays “-0100” in the following order: “-” → “0” → “1” → “0” → “0” “A” is converted to “01” (*2)</p> <p>With Imprinter installed (example): eg. When the scanner version is “B00” and the Imprinter version is “A00” (*1), “P” and the Imprinter version is indicated after the scanner version. But the Imprinter version will not be indicated if the scanner version is J00 or younger. “-” → “0” → “2” → “0” → “0” → “P” → “0” → “1” → “0” → “0” Imprinter firmware version</p>
Starting date	<p>Starting date of the scanner is displayed in 6 digits, 2 digits for “Year (Christian calendar)”, 2 digits for “Month”, and 2 digits for “Date”, following the symbol “-”. You cannot reset the date.</p> <p>eg. When the starting date is January 31st, 2002, “020131” is displayed in the following order: “-” → “0” → “2” → 0 → “1” → “3” → “1”</p>
The accumulated number of paper scanned by ADF	<p>The accumulated number of paper scanned by ADF is displayed in 8 digits from left digits to right digits, following the symbol “-”. (If the counter does not reach 8 digits, 0 is added to blank digits.) The counter increments by 10. You cannot reset this counter.</p> <p>eg. When the accumulated number is “16,245”, “00016240” is displayed in the following order: “-” → “0” → “0” → “0” → “0” → “1” → “6” → “2” → “4” → “0”</p>
The accumulated number of paper scanned by FB	<p>The accumulated number of paper scanned by FB is displayed in 8 digits from left digits to right digit. See above (ADF).</p>

08	July 27, 09	K.Okada	A.Miyoshi	I.Fujioka	Refer to Revision Record on page 2.	TITLE	fi-6140/fi-6240/fi-6130/fi-6230/fi-614PR Maintenance Manual		
07	Nov.12, 08	K.Okada	T.Anzai	I.Fujioka	Refer to Revision Record on page 2.	DRAW No.	P1PA03540-B0XX/6		CUST.
06	Mar.10, 08	K.Okada	T.Anzai	I.Fujioka	Refer to Revision Record on page 2.				
Rev.	DATE	DESIGN	CHECK	APPR.	DESCRIPTION	PFU LIMITED		Page	172 / 257
Design	July 27, 2007	K.Okada	CHECK	K.Okada		APPR.	T.Anzai		

*1: The firmware version is normally expressed by an alphabet, such as A, B or C. However, if the firmware is a beta version, two digits are added after alphabet character, such as A01, A02 or A03. So the firmware version like A00, B00 or C00 means this is an official version.

*2: As 8 segment display cannot display alphabet, alphabet is expressed by two digits as follows:

A	B	C	-----	J	K	L
01	02	03	-----	10	11	12

[How to end]

Press **Send to** button. The display returns to screen T04.

						TITLE	fi-6140/fi-6240/fi-6130/fi-6230/fi-614PR Maintenance Manual		
08	July 27, 09	K.Okada	A.Miyoshi	I.Fujioka	Refer to Revision Record on page 2.	DRAW No.	P1PA03540-B0XX/6	CUST.	
07	Nov.12, 08	K.Okada	T.Anzai	I.Fujioka	Refer to Revision Record on page 2.				
06	Mar.10, 08	K.Okada	T.Anzai	I.Fujioka	Refer to Revision Record on page 2.				
Rev.	DATE	DESIGN	CHECK	APPR.	DESCRIPTION	PFU LIMITED		Page	173 / 257
Design	July 27, 2007	K.Okada	CHECK	K.Okada		APPR.	T.Anzai		

6-1-8 Maintenance mode #7: EEPROM data restore

When replacing the Panel PCA, the EEPROM data on the Panel PCA shall be moved to the flash memory of the Control PCA. In this mode, the data is restored from the Control PCA to the Panel PCA.

[How to start]

(1) Selects Maintenance mode #7 in screen T04 and press **Scan/Stop** button. The following display appears.

Screen T71

Function No. Display	Scanner status
	“o” (lower half) blinks. Confirming whether the data shall be restored or not.

<Available buttons at screen T71>

Scan/Stop + **Function** button: Returns the data from the Control PCA to the EEPROM on the Panel PCA. During restoring operation, screen T72 is displayed.

Send to button: Terminates this mode and returns to screen T04.

Screen T72

Function No. Display	Scanner status
	“L” lights without blinking. The data is being restored.

Note: While screen T72 is displayed, no button can function.

[Display of the result]

(1) When the data restore terminated normally, the following display appears.

Screen T73

Function No. Display	Scanner status
	Displays “o” (upper half) without blinking. The data has restored normally.

<Available buttons at screen T73>

Send to button: Terminates this mode and returns to screen T04.

(2) When no data exists in the Control PCA, the following display appears.

Screen T74

Function No. Display	Scanner status
	Displays “c” without blinking. No data exists in the Control PCA.

<Available buttons at screen T74>

Send to button: Terminates this mode and returns to screen T04.

						TITLE	fi-6140/fi-6240/fi-6130/fi-6230/fi-614PR Maintenance Manual		
08	July 27, 09	K.Okada	A.Miyoshi	I.Fujioka	Refer to Revision Record on page 2.	DRAW No.	P1PA03540-B0XX/6	CUST.	
07	Nov.12, 08	K.Okada	T.Anzai	I.Fujioka	Refer to Revision Record on page 2.				
06	Mar.10, 08	K.Okada	T.Anzai	I.Fujioka	Refer to Revision Record on page 2.				
Rev.	DATE	DESIGN	CHECK	APPR.	DESCRIPTION	PFU LIMITED		Page	174 / 257
Design	July 27, 2007	K.Okada	CHECK	K.Okada		APPR.	T.Anzai		

6-2 Saving EEPROM data

The EEPROM data on the Panel PCA can be saved on the flash memory of the Control PCA. This operation is necessary before replacing the Panel PCA. Since this operation is taken when the Panel PCA is malfunctioning, save data by following the procedure below without using the operator panel.

NOTICE

- Do not conduct this procedure unless the Panel PCA is malfunctioning.
- The Panel PCA from which the data was saved to the Control PCA cannot be used again. (See NOTICE on the next page.)
- Make sure to prepare a new Panel PCA before saving the EEPROM data.

[How to save EEPROM data on the Control PCA]

1. Open the ADF cover. While pressing the TOP sensor (circle below) (=ON) and lifting up the Empty sensor (Sensor EMP) (=OFF), power on the scanner.
“P” → “H” are displayed if the Function Number display is working correctly.

Note: Lifting up the Empty sensor with a screwdriver makes the operation easier.

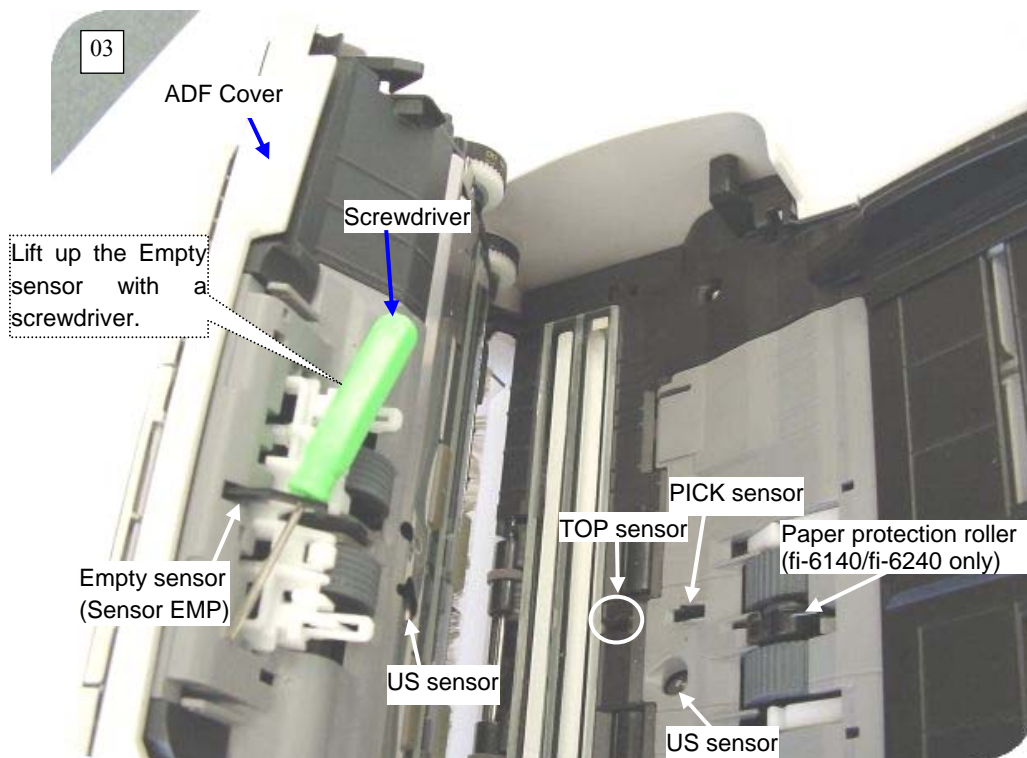

						TITLE	fi-6140/fi-6240/fi-6130/fi-6230/fi-614PR Maintenance Manual		
08	July 27, 09	K.Okada	A.Miyoshi	I.Fujioka	Refer to Revision Record on page 2.	DRAW	P1PA03540-B0XX/6	CUST.	
07	Nov.12, 08	K.Okada	T.Anzai	I.Fujioka	Refer to Revision Record on page 2.	No.			
06	Mar.10, 08	K.Okada	T.Anzai	I.Fujioka	Refer to Revision Record on page 2.				
Rev.	DATE	DESIGN	CHECK	APPR.	DESCRIPTION	PFU LIMITED		Page	175 / 257
Design	July 27, 2007	K.Okada	CHECK	K.Okada		APPR.	T.Anzai		

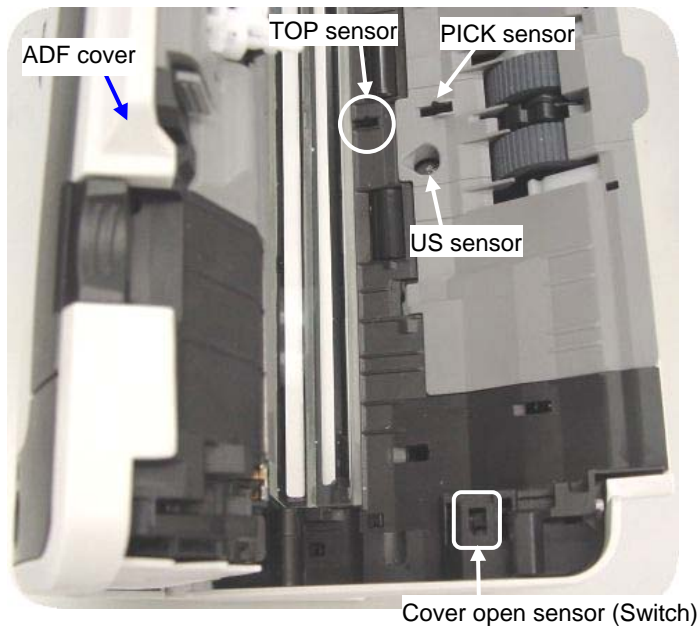

2. Leave your fingers from TOP sensor and Hopper empty sensor (Sensor EMP) lever.
3. Press TOP sensor lever more than one second and let go of it. Repeat it twice.
4. Close the ADF cover. (Close the printing section of the Imprinter as well if the Imprinter is installed.) "L" is displayed when the Function No. Display is working normally.
5. After more than 5 seconds elapse, open the ADF cover.

When the EEPROM data is successfully saved, the Lamp of ADF front blinks 3 times and "o" (upper half) is displayed on the Function No. Display.

If the EEPROM data fails to be saved, the Lamp does not light and "c" is displayed on the Function No. Display.

NOTICE

If EEPROM data is saved successfully, the scanner writes some information on the Panel PCA which disables the usage of the Panel PCA. So this Panel PCA cannot be used anymore and the Panel PCA is required to be replaced. Unless the Panel PCA is replaced, the error "E6" always appears on the panel at power on.

						TITLE	fi-6140/fi-6240/fi-6130/fi-6230/fi-614PR Maintenance Manual		
08	July 27, 09	K.Okada	A.Miyoshi	I.Fujioka	Refer to Revision Record on page 2.	DRAW	No.	P1PA03540-B0XX/6	CUST.
07	Nov.12, 08	K.Okada	T.Anzai	I.Fujioka	Refer to Revision Record on page 2.				
06	Mar.10, 08	K.Okada	T.Anzai	I.Fujioka	Refer to Revision Record on page 2.				
Rev.	DATE	DESIGN	CHECK	APPR.	DESCRIPTION	PFU LIMITED		Page	176 / 257
Design	July 27, 2007	K.Okada	CHECK	K.Okada		APPR.	T.Anzai		

Chapter 7 Basic Operation and Daily Care

7-1 Basic Operation

7-1-1 Turn ON/OFF the Scanner

- (1) Turning ON the scanner
 - Press the power button on the Operator panel.
 - The scanner is turned ON, and the Power LED on the Operator Panel lights in green.
 - Also, while the scanner is being initialized, the indication of the Function Number Display changes as follows.
 - “8” → “P” → “0” → “1”
 - The indication “1” means that the Operator Panel is in the Ready Status.

- (2) Turning OFF the scanner
 - Hold the Power button down for at least two seconds.

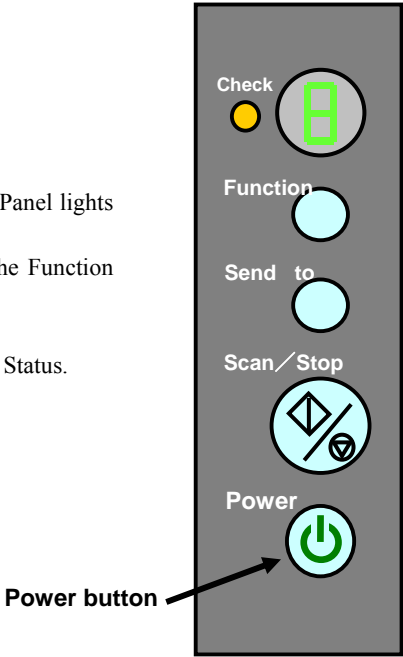

						TITLE	fi-6140/fi-6240/fi-6130/fi-6230/fi-614PR Maintenance Manual		
08	July 27, 09	K.Okada	A.Miyoshi	I.Fujioka	Refer to Revision Record on page 2.	DRAW	P1PA03540-B0XX/6	CUST.	
07	Nov.12, 08	K.Okada	T.Anzai	I.Fujioka	Refer to Revision Record on page 2.	No.			
06	Mar.10, 08	K.Okada	T.Anzai	I.Fujioka	Refer to Revision Record on page 2.				
Rev.	DATE	DESIGN	CHECK	APPR.	DESCRIPTION	PFU LIMITED		Page	177 / 257
Design	July 27, 2007	K.Okada	CHECK	K.Okada		APPR.	T.Anzai		

7-1-2 Loading Documents on the ADF for Scanning

1. Align the edges of the documents.
 - 1) Confirm that all the documents have the same width.
 - 2) Check the number of sheets in the document stack.

The standard number of sheets that can be loaded on the scanner is as follows:

 - A4/Letter-size paper or smaller that makes a document stack of 5mm or less
 - Maximum 50 sheets at A4/Letter, 20 lb., or 80 g/m²

2. Fan the documents as follows:
 - 1) Select a stack of documents 5mm or less high.
 - 2) Hold the document with both hands and fan it out several times.
 - 3) Turn the document by 90 degrees, and then fan it in the different orientation again.
 - 4) Align the document edges.

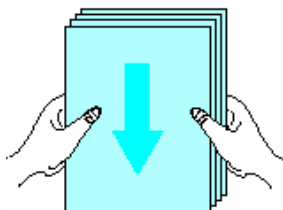

3. Load the document on the ADF paper chute (Chuter Unit).

Set the documents face-down in the ADF paper chute (Chuter Unit) (so that the side to be scanned faces towards the ADF paper chute (Chute Unit)).

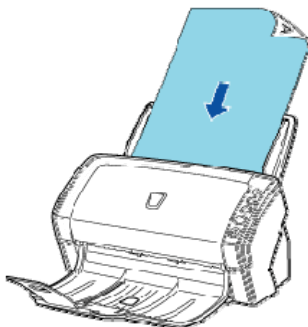

Pull out the extension to support the document when necessary.

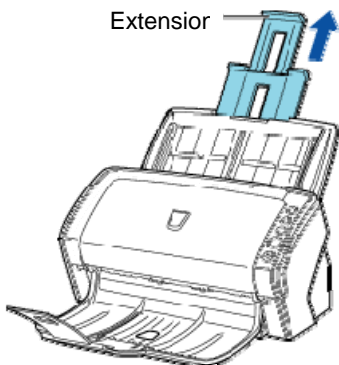

						TITLE	fi-6140/fi-6240/fi-6130/fi-6230/fi-614PR Maintenance Manual		
08	July 27, 09	K.Okada	A.Miyoshi	I.Fujioka	Refer to Revision Record on page 2.	DRAW No.	P1PA03540-B0XX/6	CUST.	
07	Nov.12, 08	K.Okada	T.Anzai	I.Fujioka	Refer to Revision Record on page 2.				
06	Mar.10, 08	K.Okada	T.Anzai	I.Fujioka	Refer to Revision Record on page 2.				
Rev.	DATE	DESIGN	CHECK	APPR.	DESCRIPTION	PFU LIMITED		Page	178 / 257
Design	July 27, 2007	K.Okada	CHECK	K.Okada		APPR.	T.Anzai		

Note: This scanner can scan ID cards through the ADF with the following precautions.

- You can place up to three cards at a time into the ADF paper chute (Chuter Unit). If the card is embossed (i.e., a card with raised lettering), place one card at a time.

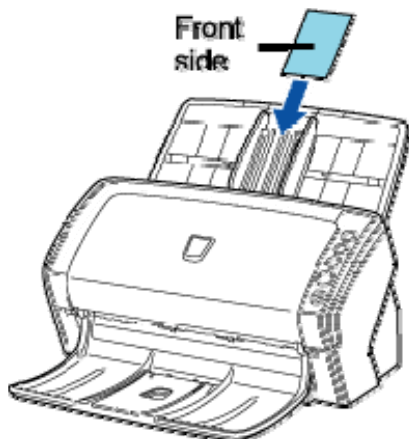

- It is recommended that smooth cards be placed face down in the ADF paper chute (Chuter Unit).
- The card to be scanned should be within the ISO7810 compliance, type ID-1.
 Dimensions: 3.4 inch (height) x 2.1 inch (width) / 86 mm x 54 mm
 Thickness: 0.056 inches / 1.4 mm or less
 Material: PVC (Poly vinyl chloride) or PVCA (Polyvinyl chloride acetate)
 * Before scanning your card, test with a dummy card of the same material to see if it can be fed into the ADF properly.
- Cards that are excessively rigid or less flexible may not feed smoothly and excessive noise may occur.
- Cards should be clean from oil and without labels.
- Cards cannot be scanned when the imprinter is installed.

4. Adjust the side guides to the width of the documents.

Move the side guides so that they touch both sides of the documents.
 If there is any space between the side guides and the edges of documents, the scanned image may be skewed.

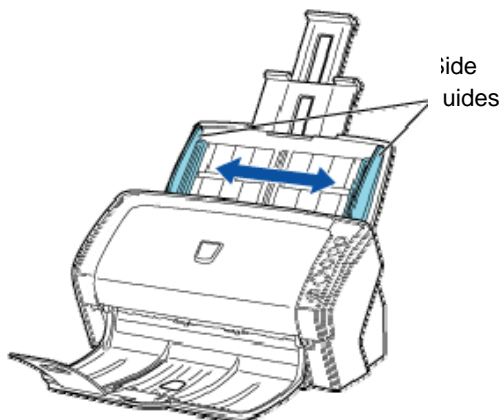

						TITLE	fi-6140/fi-6240/fi-6130/fi-6230/fi-614PR Maintenance Manual		
08	July 27, 09	K.Okada	A.Miyoshi	I.Fujioka	Refer to Revision Record on page 2.	DRAW	P1PA03540-B0XX/6	CUST.	
07	Nov.12, 08	K.Okada	T.Anzai	I.Fujioka	Refer to Revision Record on page 2.	No.			
06	Mar.10, 08	K.Okada	T.Anzai	I.Fujioka	Refer to Revision Record on page 2.				
Rev.	DATE	DESIGN	CHECK	APPR.	DESCRIPTION	PFU LIMITED		Page	179 / 257
Design	July 27, 2007	K.Okada	CHECK	K.Okada		APPR.	T.Anzai		

Notes:

The stacker prevents document sheets from dropping after they are scanned.

Lift the stacker or stacker extension and swing it forward by inserting your fingertips into the indentation(s) on the scanner as shown in the figure below.

fi-6140/fi-6130

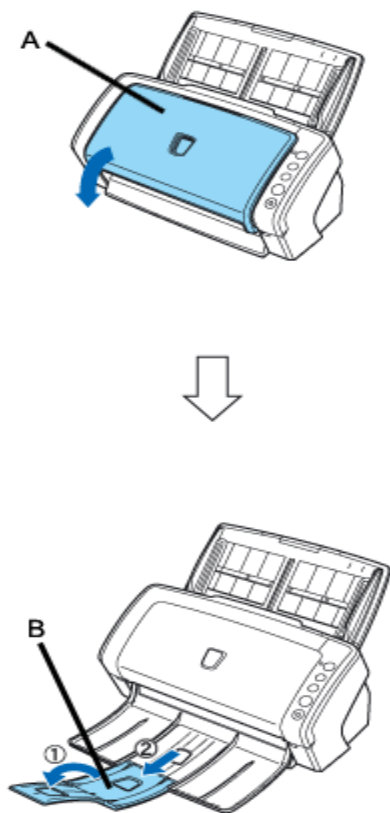

- A. Stacker
- B. Stacker extension

fi-6240/fi-6230

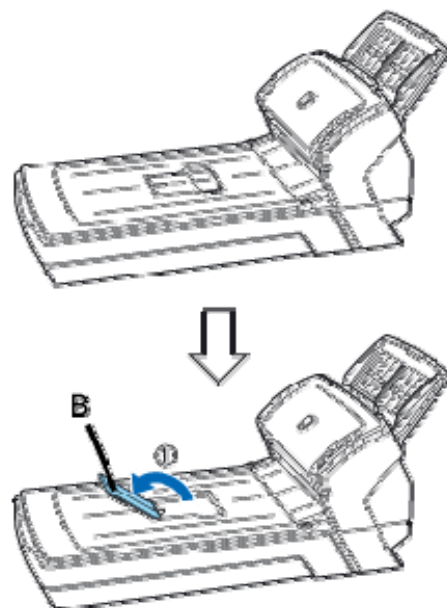

When the document size to scan is A5 or larger in length

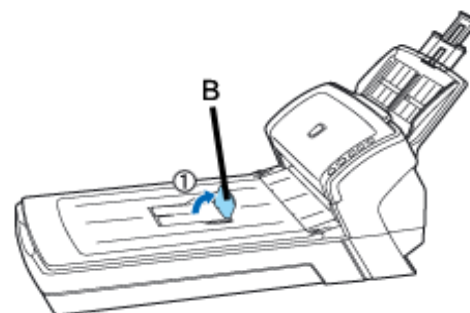

When the document size to scan is A6 or larger in length and A5 or narrower in width (To avoid damage to the stacker extension, do not open it wider than the right angle.)

5. Start up the scanner application, and scan the document.

						TITLE	fi-6140/fi-6240/fi-6130/fi-6230/fi-614PR Maintenance Manual		
08	July 27, 09	K.Okada	A.Miyoshi	I.Fujioka	Refer to Revision Record on page 2.	DRAW	P1PA03540-B0XX/6	CUST.	
07	Nov.12, 08	K.Okada	T.Anzai	I.Fujioka	Refer to Revision Record on page 2.	No.			
06	Mar.10, 08	K.Okada	T.Anzai	I.Fujioka	Refer to Revision Record on page 2.				
Rev.	DATE	DESIGN	CHECK	APPR.	DESCRIPTION	PFU LIMITED		Page	180 / 257
Design	July 27, 2007	K.Okada	CHECK	K.Okada		APPR.	T.Anzai		

7-1-3 Loading Documents on the Flatbed for Scanning fi-6240/fi-6230

1. Lift up the Document Cover.

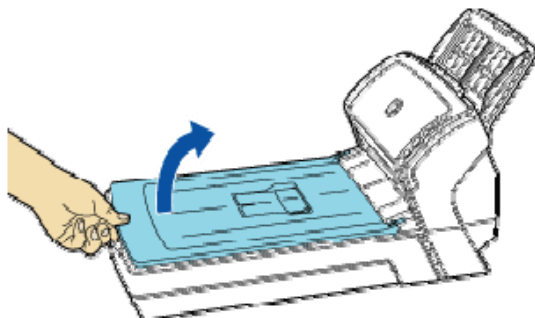

2. Load the document on the document bed with the scanning face down and the top left corner aligned with the reference point.

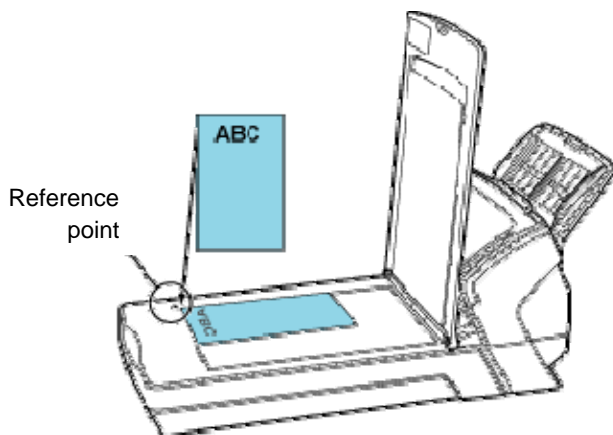

3. Gently close the Document Cover.

4. Start up the scanner application, and scan the document.

						TITLE	fi-6140/fi-6240/fi-6130/fi-6230/fi-614PR Maintenance Manual		
08	July 27, 09	K.Okada	A.Miyoshi	I.Fujioka	Refer to Revision Record on page 2.	DRAW	P1PA03540-B0XX/6	CUST.	
07	Nov.12, 08	K.Okada	T.Anzai	I.Fujioka	Refer to Revision Record on page 2.	No.			
06	Mar.10, 08	K.Okada	T.Anzai	I.Fujioka	Refer to Revision Record on page 2.				
Rev.	DATE	DESIGN	CHECK	APPR.	DESCRIPTION	PFU LIMITED		Page	181 / 257
Design	July 27, 2007	K.Okada	CHECK	K.Okada		APPR.	T.Anzai		

7-2 Daily Care

⚠ CAUTION

The glass surface of the ADF becomes very hot during the operation of the scanner. Before you start to clean the inner parts of the scanner, disconnect the AC adapter from the power outlet, and wait for at least 15 minutes to let the glass cool down. Do not turn off the scanner when you clean the Feed and Eject rollers.

As a guideline, clean the ADF every 5,000 scanned sheets. The scanner must be cleaned more frequently when the following documents are used.

- Documents of coated paper
- Documents with printed text or graphics almost covering the entire surface
- Chemically treated documents such as carbonless paper
- Documents containing a large amount of calcium carbonate
- Documents written by pencil
- Documents on which the toner is not fused sufficiently

Note: Do not use point thinner or other organic solvents instead of ethyl alcohol.

7-2-1 Cleaning the ADF

How to clean:

1. Open the ADF by pushing on the ADF open lever and turning the ADF cover to the front.

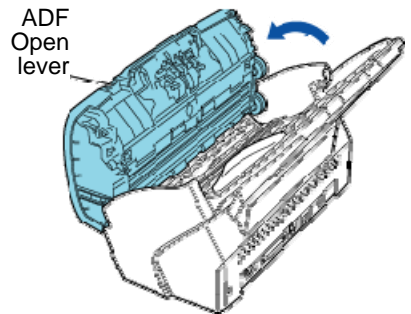

⚠ CAUTION

Be careful, the ADF cover may close and pinch your finger.

2. Clean the following locations with a soft, dry cloth or a cloth moistened with cleaning fluid (ethyl alcohol).

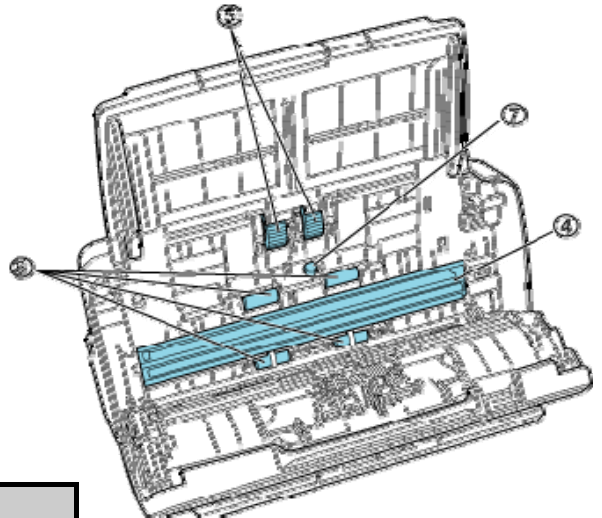
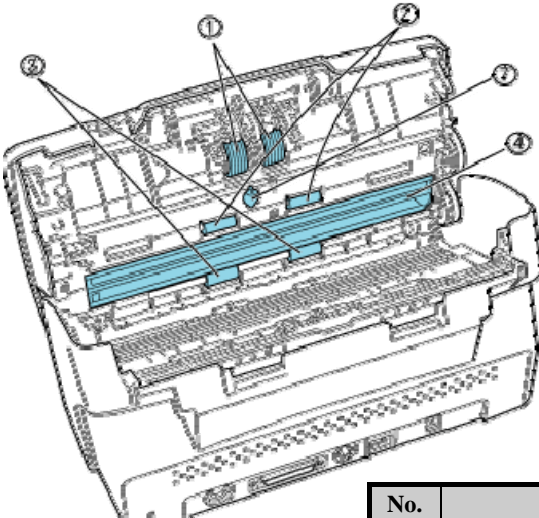

No.	Item
1	Brake rollers (x2)
2	Feed rollers (x2)
3	Eject rollers (x2)
4	Glasses (x2)
5	Pick rollers (x2)
6	Plastic rollers (x4)
7	Ultrasonic sensor

						TITLE	fi-6140/fi-6240/fi-6130/fi-6230/fi-614PR Maintenance Manual		
08	July 27, 09	K.Okada	A.Miyoshi	I.Fujioka	Refer to Revision Record on page 2.	DRAW	P1PA03540-B0XX/6	CUST.	
07	Nov.12, 08	K.Okada	T.Anzai	I.Fujioka	Refer to Revision Record on page 2.	No.			
06	Mar.10, 08	K.Okada	T.Anzai	I.Fujioka	Refer to Revision Record on page 2.				
Rev.	DATE	DESIGN	CHECK	APPR.	DESCRIPTION	PFU LIMITED		Page	182 / 257
Design	July 27, 2007	K.Okada	CHECK	K.Okada		APPR.	T.Anzai		

Note: To avoid damaging the document sensors, take care that the cloth does not get hooked into them when cleaning the inside of the ADF.

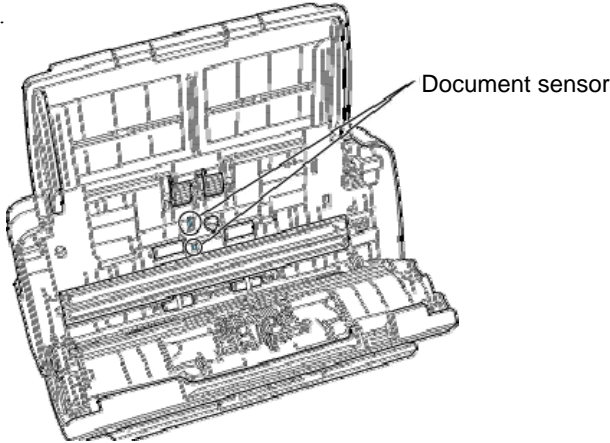

- Brake roller

Lightly clean the Brake roller along the grooves on the roller taking care not to scratch the roller surface. When cleaning the Brake roller, remove it from the scanner. For how to remove the Brake roller, refer to Section 7-3-3 “Replacing the Brake rollers.”

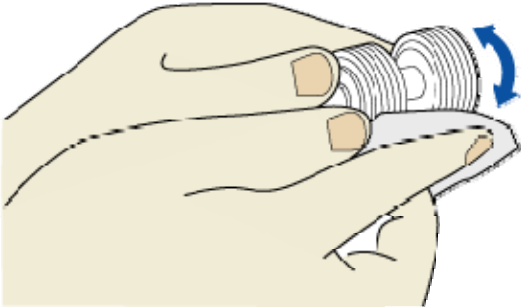

- Pick roller

Lightly clean the Pick roller along the grooves on the roller taking care not to scratch the roller surface. Take particular care in cleaning this roller as black debris on it adversely affects the pickup performance.

- Plastic roller

Lightly clean the Plastic roller taking care not to damage the roller surface. Take particular care in cleaning this roller as black debris on it adversely affects the pickup performance. Be careful not to damage the sponges beside the rollers.

- Glass

Clean lightly.
If the glass is dirty, vertical black streaks may appear in the scanned images.

- Ultrasonic sensor

Clean lightly with a dry cloth.
If the glass is dirty, vertical black streaks may appear in the scanned images.

						TITLE	fi-6140/fi-6240/fi-6130/fi-6230/fi-614PR Maintenance Manual		
08	July 27, 09	K.Okada	A.Miyoshi	I.Fujioka	Refer to Revision Record on page 2.	DRAW No.	P1PA03540-B0XX/6	CUST.	
07	Nov.12, 08	K.Okada	T.Anzai	I.Fujioka	Refer to Revision Record on page 2.				
06	Mar.10, 08	K.Okada	T.Anzai	I.Fujioka	Refer to Revision Record on page 2.				
Rev.	DATE	DESIGN	CHECK	APPR.	DESCRIPTION	PFU LIMITED		Page	183 / 257
Design	July 27, 2007	K.Okada	CHECK	K.Okada		APPR.	T.Anzai		

- Feed roller/Eject roller

Rotate the rollers in the following procedure:

- 1) Open the ADF when the indication of the Function Number Display is not “P” or “0.”
If you open the ADF when the indication of the Function Number display is “P” or “0,” the Feed rollers/Eject rollers will not rotate even you perform the operation below.
- 2) Simultaneously hold down the **Send to** and **Scan/Stop** buttons on the Operator Panel. The Feed rollers/Eject rollers start to rotate slowly.

⚠ CAUTION

All the Feed rollers/Eject rollers turn at the same time. When cleaning the Feed rollers or Eject rollers, be careful not to touch the other rotating Feed rollers/Eject rollers.

- 3) Hold a soft cloth moistened with cleaning fluid (ethyl alcohol) against the surface of the rotating Feed rollers so that it lightly cleans the surface of the rollers. Take particular care when cleaning these rollers as black debris on these rollers affects pickup performance. As a guideline, seven presses of the **Send to** and **Scan/Stop** buttons make the Feed rollers/Eject rollers to rotate one full turn.

3. Press down on the center of the ADF to return it to its original position until the ADF button locks.

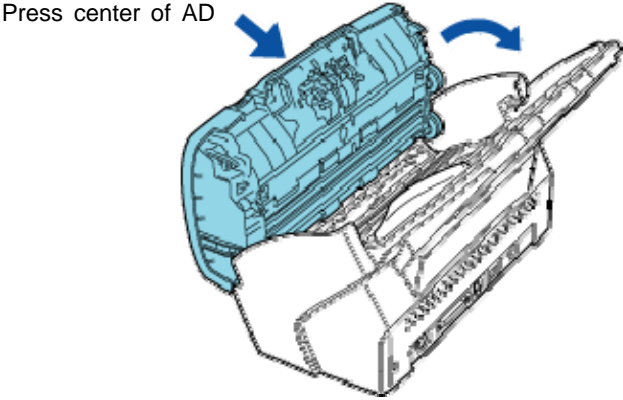

Note: When the ADF has returned to its original position, make sure that it is completely closed. Feeding errors may occur if the ADF is not closed completely.

						TITLE	fi-6140/fi-6240/fi-6130/fi-6230/fi-614PR Maintenance Manual		
08	July 27, 09	K.Okada	A.Miyoshi	I.Fujioka	Refer to Revision Record on page 2.	DRAW No.	P1PA03540-B0XX/6	CUST.	
07	Nov.12, 08	K.Okada	T.Anzai	I.Fujioka	Refer to Revision Record on page 2.				
06	Mar.10, 08	K.Okada	T.Anzai	I.Fujioka	Refer to Revision Record on page 2.				
Rev.	DATE	DESIGN	CHECK	APPR.	DESCRIPTION	PFU LIMITED		Page	184 / 257
Design	July 27, 2007	K.Okada	CHECK	K.Okada		APPR.	T.Anzai		

7-2-2 Cleaning the Flatbed **fi-6240/fi-6230**

How to clean:

1. Open the document cover.

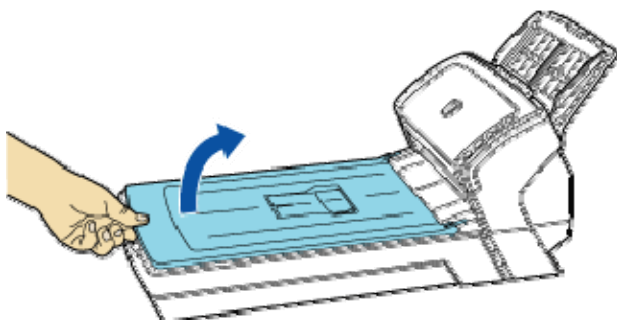

2. Clean the following locations using a soft cloth moistened with cleaning fluid (ethyl alcohol).

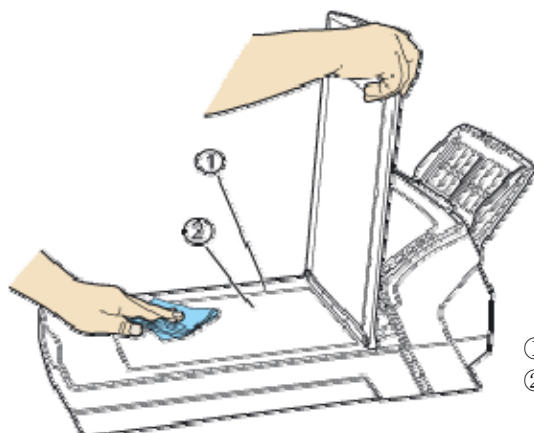

- ① Plastic cover
- ② Document bed

Note: Do not allow moisture to get inside the device during cleaning.

3. Wait for cleaned parts to dry.
4. Gently close the document cover.

						TITLE	fi-6140/fi-6240/fi-6130/fi-6230/fi-614PR Maintenance Manual		
08	July 27, 09	K.Okada	A.Miyoshi	I.Fujioka	Refer to Revision Record on page 2.	DRAW	P1PA03540-B0XX/6	CUST.	
07	Nov.12, 08	K.Okada	T.Anzai	I.Fujioka	Refer to Revision Record on page 2.	No.			
06	Mar.10, 08	K.Okada	T.Anzai	I.Fujioka	Refer to Revision Record on page 2.				
Rev.	DATE	DESIGN	CHECK	APPR.	DESCRIPTION	PFU LIMITED		Page	185 / 257
Design	July 27, 2007	K.Okada	CHECK	K.Okada		APPR.	T.Anzai		

7-3 Replacing the consumables

CAUTION

The glass surface of the ADF becomes very hot during the operation of the scanner. Before you replace the consumables, disconnect the AC adapter from the power outlet, and wait for at least 15 minutes to let the glass cool down.

7-3-1 Consumables

The scanner has the following consumables which users need to replace at the following intervals. To check the number of scanned documents, go to Maintenance mode (Section 6-1-6) or the [Software Operation panel] (Section 7-3-2).

Table 7-3-1

No.	Part name	Specifications	Standard replacement cycle	How to check the number of scanned documents	How to replace
1	Brake roller	PA03540-0001	200,000 sheets or one year	Section 6-1-6 Section 7-3-2.	Section 7-3-3.
2	Pick roller	PA03540-0002	200,000 sheets or one year		Section 7-3-4.

The replacement cycles above are rough guidelines for the case of using A4/Letter woodfree or wood containing paper 64g/m² (171b). This cycle varies according to the type of the paper used and how frequently the scanner is used and cleaned.

Note: Use only the specified consumables to avoid document feeding trouble.

						TITLE	fi-6140/fi-6240/fi-6130/fi-6230/fi-614PR Maintenance Manual		
08	July 27, 09	K.Okada	A.Miyoshi	I.Fujioka	Refer to Revision Record on page 2.	DRAW No.	P1PA03540-B0XX/6	CUST.	
07	Nov.12, 08	K.Okada	T.Anzai	I.Fujioka	Refer to Revision Record on page 2.				
06	Mar.10, 08	K.Okada	T.Anzai	I.Fujioka	Refer to Revision Record on page 2.				
Rev.	DATE	DESIGN	CHECK	APPR.	DESCRIPTION	PFU LIMITED		Page	186 / 257
Design	July 27, 2007	K.Okada	CHECK	K.Okada		APPR.	T.Anzai		

7-3-2 Checking and Resetting the Consumables Counters

For confirming the abrasion of consumables and resetting the counters, use [Software Operation Panel] on your computer as shown below.

1. Confirm is the scanner is connected correctly to the computer, and then turn on the scanner.
2. From the [start] menu, select [All Programs]→[Scanner Utility for Microsoft Windows]→[Software Operation Panel].

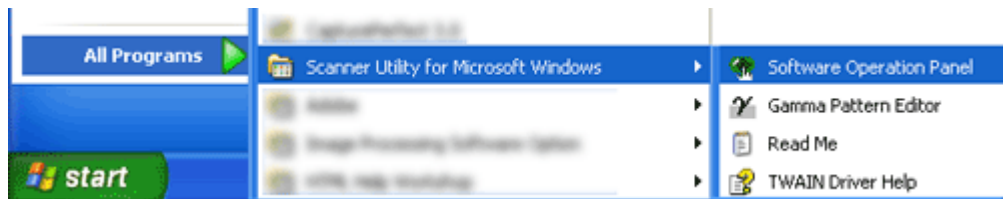

→ The [Software Operation Panel] dialog box appears.

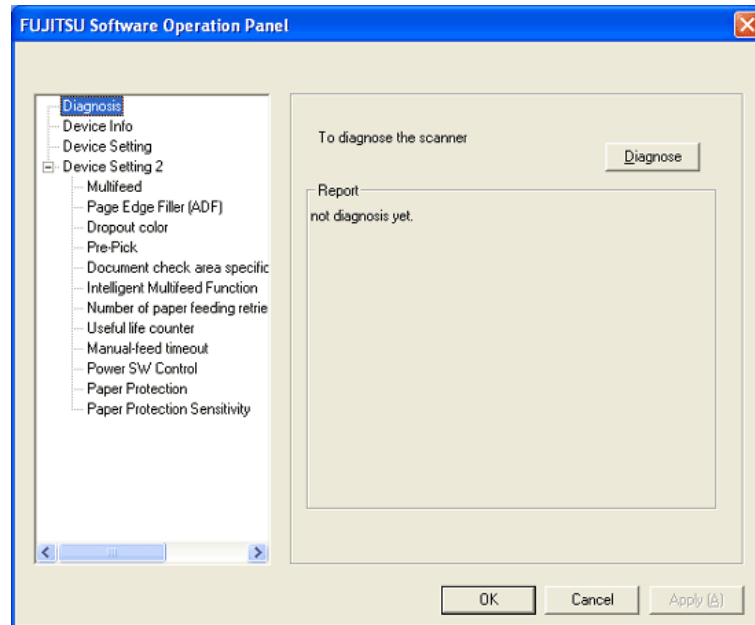

3. From the list on the left of the panel, select [Device Setting].

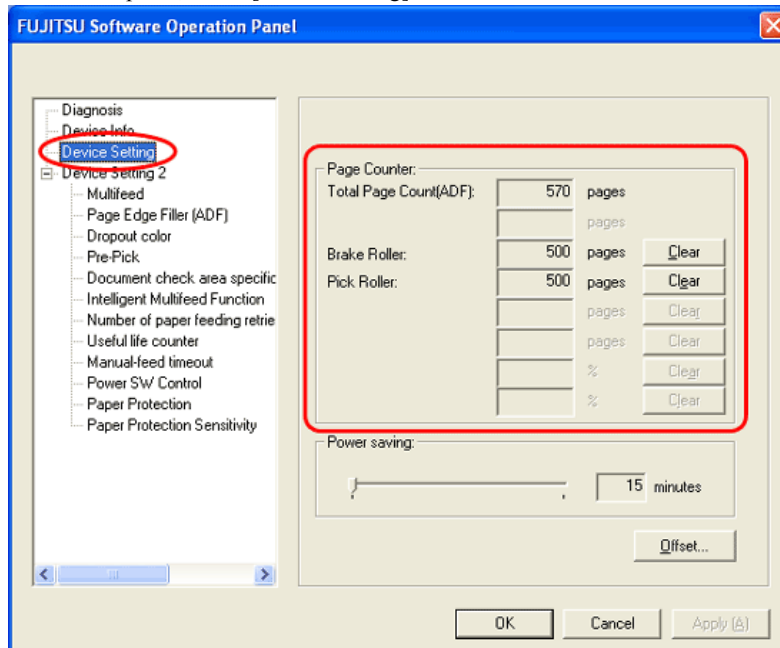

						TITLE	fi-6140/fi-6240/fi-6130/fi-6230/fi-614PR Maintenance Manual		
08	July 27, 09	K.Okada	A.Miyoshi	I.Fujioka	Refer to Revision Record on page 2.	DRAW No.	P1PA03540-B0XX/6		CUST.
07	Nov.12, 08	K.Okada	T.Anzai	I.Fujioka	Refer to Revision Record on page 2.				
06	Mar.10, 08	K.Okada	T.Anzai	I.Fujioka	Refer to Revision Record on page 2.				
Rev.	DATE	DESIGN	CHECK	APPR.	DESCRIPTION	PFU LIMITED		Page	187 / 257
Design	July 27, 2007	K.Okada	CHECK	K.Okada		APPR.	T.Anzai		

You can confirm the following information in this panel:

Total Page Count (ADF)	Total scanned sheets
Brake Roller	Number of sheets scanned since last replacement of the Brake roller
Pick Roller	Number of sheets scanned since last replacement of the Pick roller
Remaining Ink	Remaining ink in the imprinter's (sold separately) ink cartridge. (Displayed only when the imprinter option is used.)

4. If you replaced any consumable, click the [Clear] button beside it.

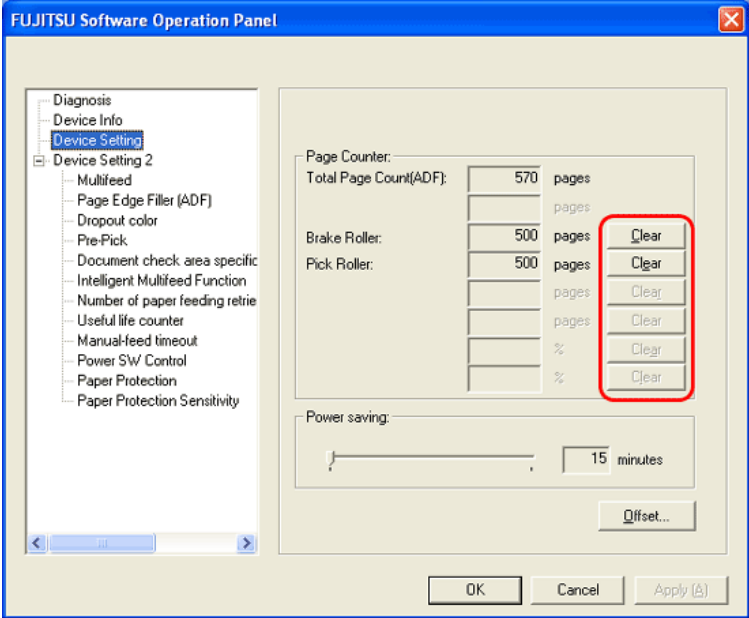

5. Click the [OK] button on the displayed confirmation message.

- ➔ The counter is reset to 0.
(The remaining ink indication (percentage) is reset to 100.)

6. If you want to close the [Software Operation Panel] dialog box, click the [OK] button.

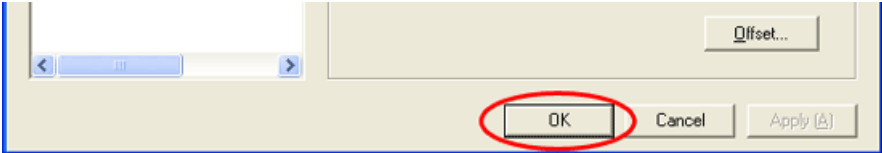

[Consumables Replacement Message]

The following message may appear while using the scanner:

When you click the [Ignore] button, this message disappears and scanning continues. You may be able to continue scanning for a while, however, it is recommended that you replace the consumable as soon as possible. To stop the scanning and replace the consumable right away, click the [Cancel] button.

For the replacement of consumables, refer to the following sections.
 Pick roller: Section 7-3-3
 Brake roller: Section 7-3-4

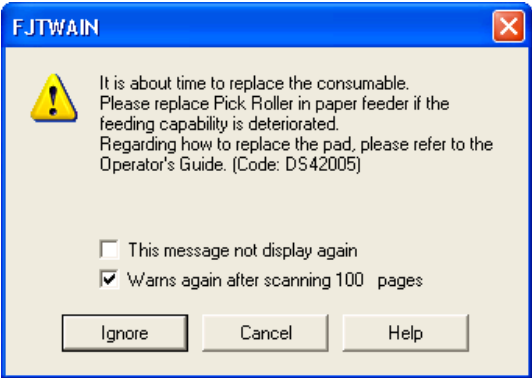

						TITLE	fi-6140/fi-6240/fi-6130/fi-6230/fi-614PR Maintenance Manual		
08	July 27, 09	K.Okada	A.Miyoshi	I.Fujioka	Refer to Revision Record on page 2.	DRAW No.	P1PA03540-B0XX/6		CUST.
07	Nov.12, 08	K.Okada	T.Anzai	I.Fujioka	Refer to Revision Record on page 2.				
06	Mar.10, 08	K.Okada	T.Anzai	I.Fujioka	Refer to Revision Record on page 2.				
Rev.	DATE	DESIGN	CHECK	APPR.	DESCRIPTION	PFU LIMITED		Page	188 / 257
Design	July 27, 2007	K.Okada	CHECK	K.Okada		APPR.	T.Anzai		

7-3-3 Brake roller replacement

Refer to Section 7-3-1 for the specification of the Brake roller.

- (1) Remove any documents from the ADF paper chute (Chuter Unit).
- (2) Open the ADF by pulling the ADF open level and turning the ADF cover to the front.

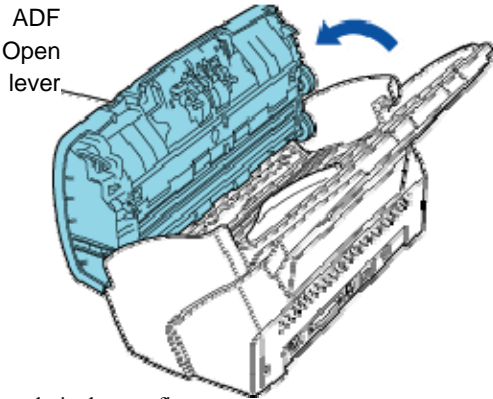

⚠ CAUTION

Be careful, the ADF cover may close and pinch your finger.

- (3) Remove the Brake roller from the scanner.
 - 1) Grab both sides of the Brake roller cover, and press to the inside and pull down (towards you), as shown in the illustration below.

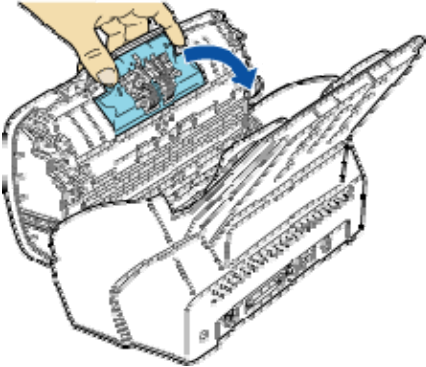

- 2) Lift up the right side of the Brake roller and remove the right shaft. Then pull the left shaft out of its hole to remove it.

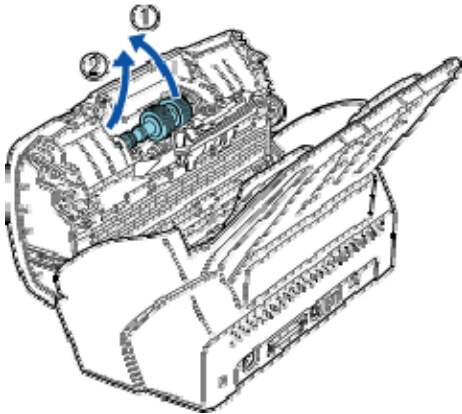

- (4) Remove the Brake roller from the shaft.

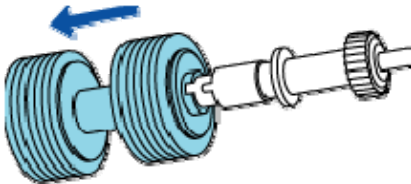

						TITLE	fi-6140/fi-6240/fi-6130/fi-6230/fi-614PR Maintenance Manual		
08	July 27, 09	K.Okada	A.Miyoshi	I.Fujioka	Refer to Revision Record on page 2.	DRAW No.	P1PA03540-B0XX/6	CUST.	
07	Nov.12, 08	K.Okada	T.Anzai	I.Fujioka	Refer to Revision Record on page 2.				
06	Mar.10, 08	K.Okada	T.Anzai	I.Fujioka	Refer to Revision Record on page 2.				
Rev.	DATE	DESIGN	CHECK	APPR.	DESCRIPTION	PFU LIMITED		Page	189 / 257
Design	July 27, 2007	K.Okada	CHECK	K.Okada		APPR.	T.Anzai		

(5) Insert the shaft to the new Brake roller aligning the shaft tab with the slot of the Brake roller.

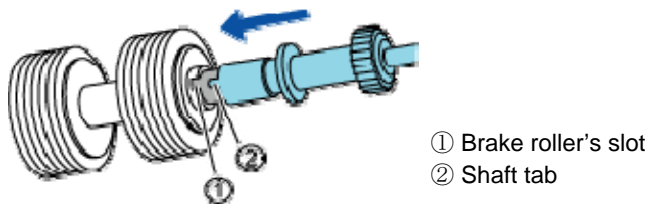

(6) Attach the Brake roller to the scanner in the reverse order of removing.

1) Set the left side of the Brake roller into place first, then fix the right side of the roller.

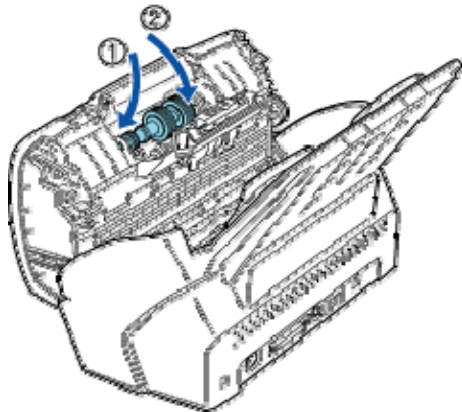

2) Close the Brake roller cover.

(7) Close the ADF. Press down on the center of the ADF to return it to its original position until the ADF button locks.

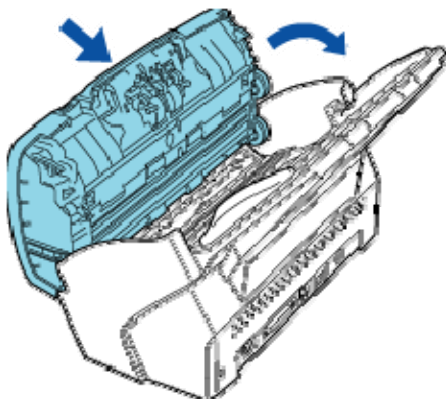

(8) Reset the Brake roller counter (Section 7-3-2).

						TITLE	fi-6140/fi-6240/fi-6130/fi-6230/fi-614PR Maintenance Manual		
08	July 27, 09	K.Okada	A.Miyoshi	I.Fujioka	Refer to Revision Record on page 2.	DRAW	P1PA03540-B0XX/6	CUST.	
07	Nov.12, 08	K.Okada	T.Anzai	I.Fujioka	Refer to Revision Record on page 2.	No.			
06	Mar.10, 08	K.Okada	T.Anzai	I.Fujioka	Refer to Revision Record on page 2.				
Rev.	DATE	DESIGN	CHECK	APPR.	DESCRIPTION	PFU LIMITED		Page	190 / 257
Design	July 27, 2007	K.Okada	CHECK	K.Okada		APPR.	T.Anzai		

7-3-4 Pick roller replacement

Refer to Section 7-3-1 for the specification of the Pick roller.

- (1) Remove any documents from the ADF paper chute (Chuter Unit) and remove the ADF paper chute (Chute Unit) from the scanner.

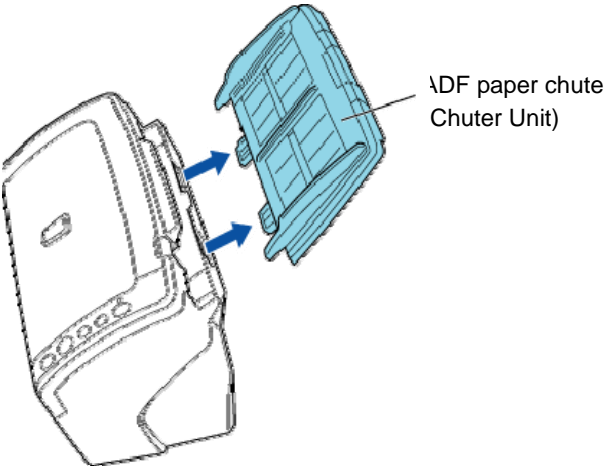

- (2) Open the ADF by pulling the ADF open lever and turning the ADF cover to the front.

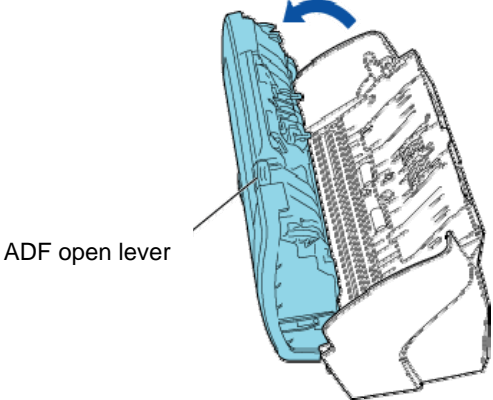

CAUTION

Be careful, the ADF cover may close and pinch your finger.

- (3) Remove the Pick roller from the scanner.
 - 1) Pinch the knobs on the Guide P ASSY (Sheet Guide) and lift up the GUIDE P ASSY (Sheet Guide) to remove it.

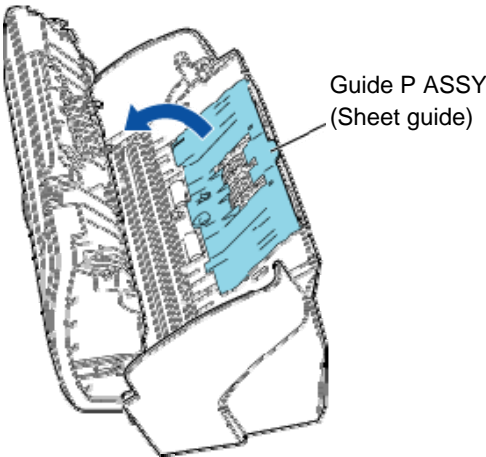

						TITLE	fi-6140/fi-6240/fi-6130/fi-6230/fi-614PR		
08	July 27, 09	K.Okada	A.Miyoshi	I.Fujioka	Refer to Revision Record on page 2.		Maintenance Manual		
07	Nov.12, 08	K.Okada	T.Anzai	I.Fujioka	Refer to Revision Record on page 2.	DRAW	P1PA03540-B0XX/6		CUST.
06	Mar.10, 08	K.Okada	T.Anzai	I.Fujioka	Refer to Revision Record on page 2.	No.			
Rev.	DATE	DESIGN	CHECK	APPR.	DESCRIPTION	PFU LIMITED		Page	191 / 257
Design	July 27, 2007	K.Okada	CHECK	K.Okada		APPR.	T.Anzai		

2) Rotate the Pick roller lever in the direction of the arrow.

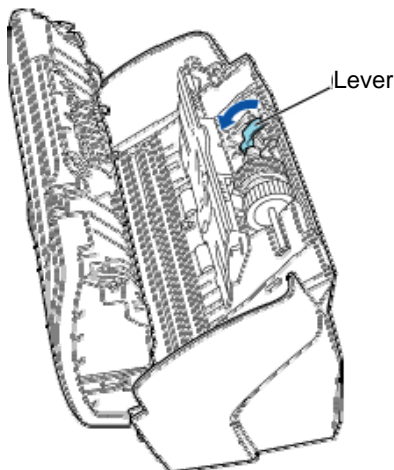

2) Slide the Pick roller in the direction of the arrow, and then lift it up to remove the shaft from the hole.

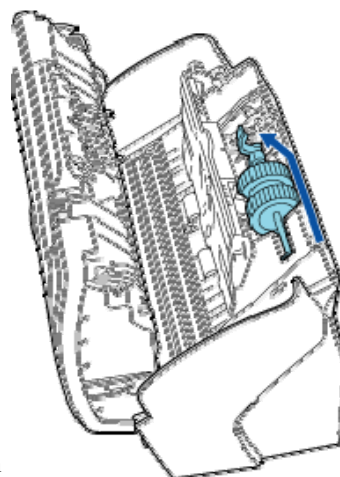

(4) Remove the Pick roller from the shaft while lifting up the tab on the Pick roller.

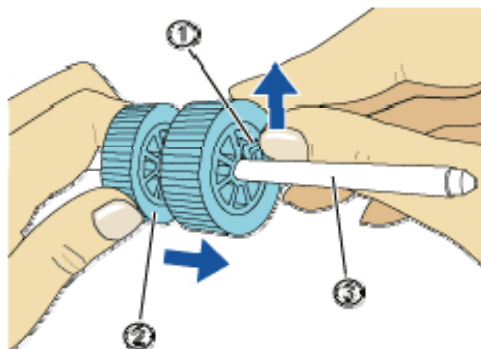

- ① Tab
- ② Pick roller
- ③ Shaft

CAUTION

If you lift the pick roller tab with your fingernail, it may hurt your fingernail. Use a paper clip to lift the pick roller tab if you cannot do it with your finger.

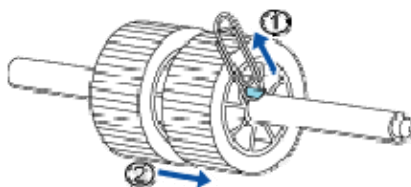

						TITLE	fi-6140/fi-6240/fi-6130/fi-6230/fi-614PR Maintenance Manual		
08	July 27, 09	K.Okada	A.Miyoshi	I.Fujioka	Refer to Revision Record on page 2.	DRAW	P1PA03540-B0XX/6	CUST.	
07	Nov.12, 08	K.Okada	T.Anzai	I.Fujioka	Refer to Revision Record on page 2.	No.			
06	Mar.10, 08	K.Okada	T.Anzai	I.Fujioka	Refer to Revision Record on page 2.				
Rev.	DATE	DESIGN	CHECK	APPR.	DESCRIPTION	PFU LIMITED		Page	192 / 257
Design	July 27, 2007	K.Okada	CHECK	K.Okada		APPR.	T.Anzai		

- (5) Attach a new Pick roller.
 Insert the new Pick roller aligning the screw on the shaft with the slot in the Pick roller.

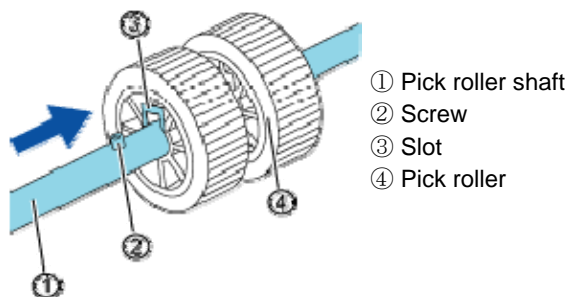

Note: Make sure that the Pick roller is correctly attached. The incompletely-attached Pick roller might cause document jams or other feed errors. When attaching the Pick roller to the shaft, make sure that the roller's tab clicks into place.

- (6) Attach the Pick roller to the scanner in the reverse order of removing.
 1) Set the right side of the Pick roller into place first, then fix the left side to the roller.

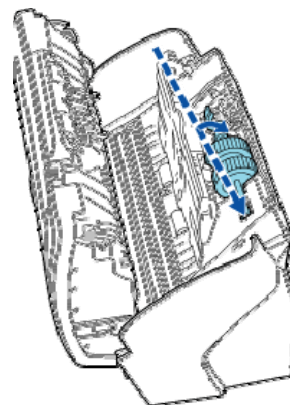

- 2) Rotate the Pick roller lever in the direction of the arrow.

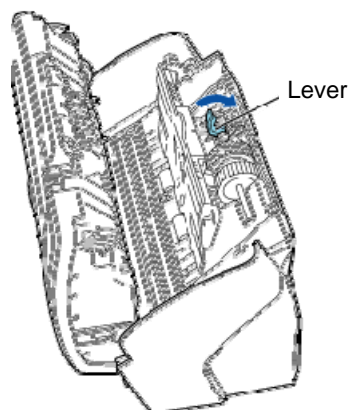

- 3) Close the Guide P ASSY (Sheet Guide).

- (7) Close the ADF. Press down on the center of the ADF to return it to its original position until the ADF button locks.

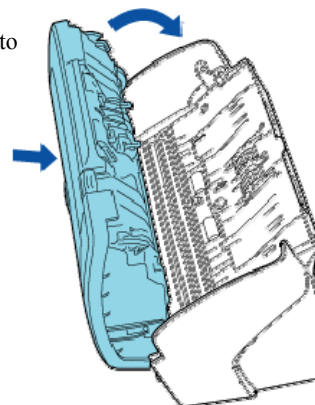

- (8) Attach the ADF paper chute (Chuter Unit) to the scanner
 (9) Reset the Pick roller counter. (Refer to Section 7-3-2.)

						TITLE	fi-6140/fi-6240/fi-6130/fi-6230/fi-614PR Maintenance Manual		
08	July 27, 09	K.Okada	A.Miyoshi	I.Fujioka	Refer to Revision Record on page 2.	DRAW	P1PA03540-B0XX/6	CUST.	
07	Nov.12, 08	K.Okada	T.Anzai	I.Fujioka	Refer to Revision Record on page 2.	No.			
06	Mar.10, 08	K.Okada	T.Anzai	I.Fujioka	Refer to Revision Record on page 2.				
Rev.	DATE	DESIGN	CHECK	APPR.	DESCRIPTION	PFU LIMITED		Page	193 / 257
Design	July 27, 2007	K.Okada	CHECK	K.Okada		APPR.	T.Anzai		

Chapter 8 Imprinter (Optional)

8-1 Imprinter Specifications

8-1-1 Printing Functions

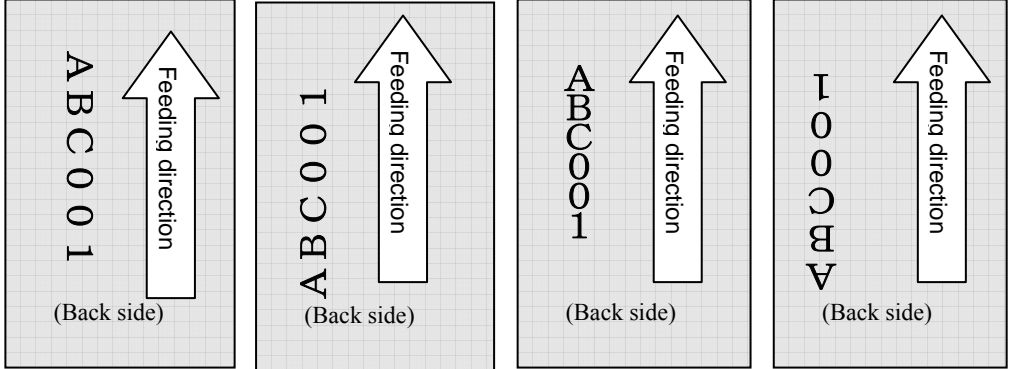
No.	Items	Specifications
1	Printing method	Thermal inkjet printing
2	Print timing	Post imprinting (imprinting after scanning the image)
3	Printing direction	Document feeding direction
4	Printing side	Back side
5	Printing characters	Alphabet (52 kinds): A~Z, a~z Numeric Characters (10 kinds): 0, 1~9 Symbols (32 kinds): ! " # \$ % & ' () * + , - . / : ; < = > ? @ [\] ^ _ ` { } ~ * Printing characters cannot be downloaded. * Special characters cannot be printed. * Character spacing cannot be specified.
6	Maximum character	43 characters
7	Printing direction	 <p>Normal: 0° 180° (horizontal) 90° 270° (vertical) Narrow: 0° 180° (horizontal)</p>
8	Character size (vert x hori)	Normal, Bold: 2.91 (H) x 2.82 (W) mm (horizontal orientation) 2.82 (H) x 2.91 (W) mm (vertical orientation) Virtual body size (dot center) Narrow: 2.91 (H) x 2.12 (W) mm (horizontal orientation)
9	Dot matrix of character	Normal, Bold Horizontal orientation: 12 dots (vertical) x 9 dots (horizontal) Vertical orientation: 9 dots (vertical) x 12 dots (horizontal) Virtual body size (dot center) Thin Horizontal orientation: 12 dots (vertical) x 7 dots (horizontal)
10	Character pitch	3.53mm (Normal), 2.54 (Narrow)
11	Document requirement	Paper weight: 52 ~ 128 g/m ² Documents supported by fi-6130/fi-6140. Documents with glossy surface such as coated paper and art paper which may take longer time for the ink to dry cannot be printed on.

						TITLE	fi-6140/fi-6240/fi-6130/fi-6230/fi-614PR Maintenance Manual		
08	July 27, 09	K.Okada	A.Miyoshi	I.Fujioka	Refer to Revision Record on page 2.	DRAW	P1PA03540-B0XX/6	CUST.	
07	Nov.12, 08	K.Okada	T.Anzai	I.Fujioka	Refer to Revision Record on page 2.	No.			
06	Mar.10, 08	K.Okada	T.Anzai	I.Fujioka	Refer to Revision Record on page 2.				
Rev.	DATE	DESIGN	CHECK	APPR.	DESCRIPTION	PFU LIMITED		Page	194 / 257
Design	July 27, 2007	K.Okada	CHECK	K.Okada		APPR.	T.Anzai		

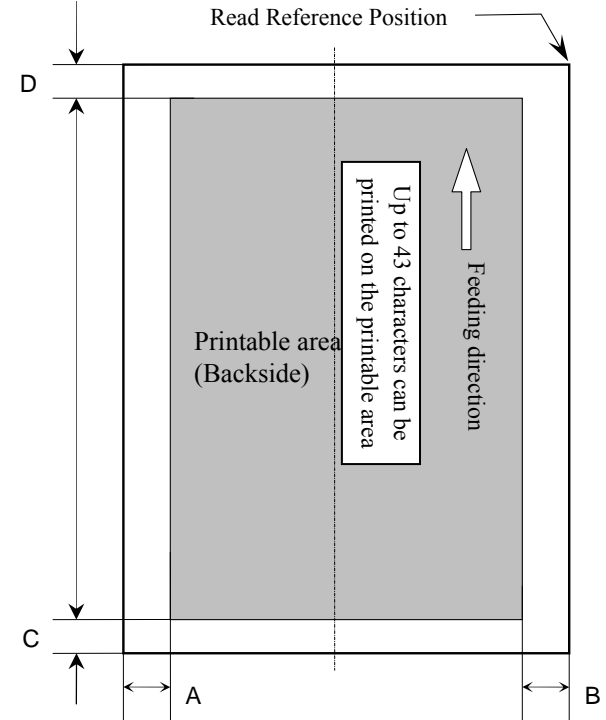
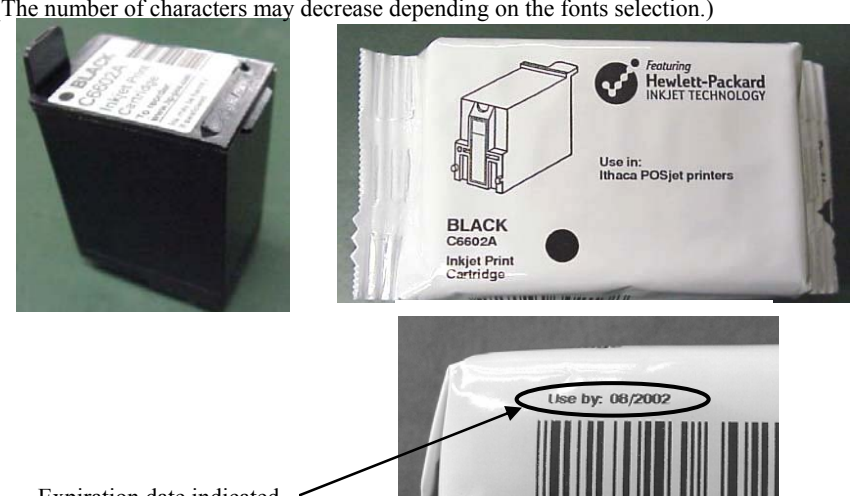
No.	Items	Specifications
12	Printable area	<p>Read Reference Position</p>  <p> $A \geq 5\text{mm}$ $B \geq 5\text{mm}$ $C \geq 5\text{mm}$ $D \geq 5\text{mm}$ (0.20 inch) </p>
10	Accuracy of printing position	$\pm 4\text{mm}$ from the starting point for feeding direction
11	Consumables	<p>Print cartridge (P/N.: CA00050-0262) Print color: Black Replacement cycle: 4,000,000 characters (The number of characters may decrease depending on the fonts selection.)</p>  <p>Expiration date indicated</p>

8-1-2 Environmental Specifications

No.	Items	Specifications
1	Outer dimensions (mm)	301 (W) x 251 (D) x 139 (H) mm / 11.85(W) x 9.88 (D) x 5.47 (H) in. (Imprinter only. Interface cable not included) 301 (W) x 253 (D) x 203 (H) mm / 11.85 (W) x 9.96 (D) x 7.99 (H) in. (With scanner. Interface cable, Chuter Unit, and Stacker not included.)
2	Weights	2.8kg (6.18lb) or less
3	Shipping dimensions	364 (W) x 462 (D) x 314 (H) mm / 14.3 (W) x 18.19 (D) x 12.37(H) in.
4	Shipping weight	4.5kg (9.93lb) or less
5	Ambient condition	Temperature: 10 to 35 °C (50 to 95 °F) Humidity: 20 to 80%

Rev.	DATE	DESIGN	CHECK	APPR.	DESCRIPTION	TITLE	fi-6140/fi-6240/fi-6130/fi-6230/fi-614PR		
08	July 27, 09	K.Okada	A.Miyoshi	I.Fujioka	Refer to Revision Record on page 2.	Maintenance Manual			
07	Nov.12, 08	K.Okada	T.Anzai	I.Fujioka	Refer to Revision Record on page 2.		DRAW No.	P1PA03540-B0XX/6	CUST.
06	Mar.10, 08	K.Okada	T.Anzai	I.Fujioka	Refer to Revision Record on page 2.				
Design	July 27, 2007	K.Okada	CHECK	K.Okada	APPR.	T.Anzai	PFU LIMITED	Page	195 / 257

8-1-3 Appearance

<Imprinter unit>

Front side

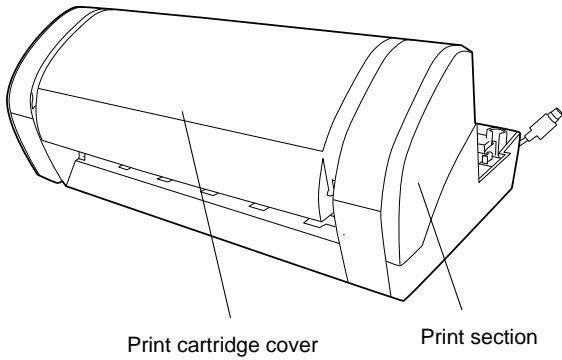

Rear side

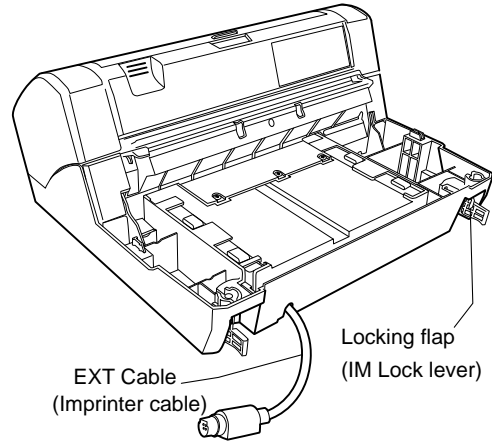

<Imprinter with Scanner Installed>

Front side

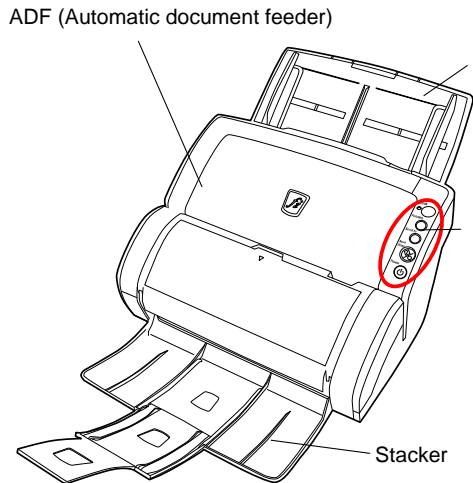

Rear side

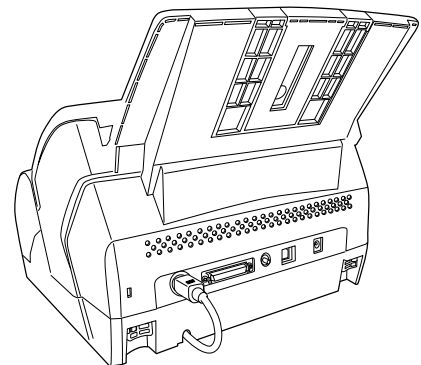

- Operator Panel**
- Function No. Display
 - [Function] button
 - [Send to] button
 - [Scan/Stop] button
 - Power button
 - LED

Open Print Cartridge Cover

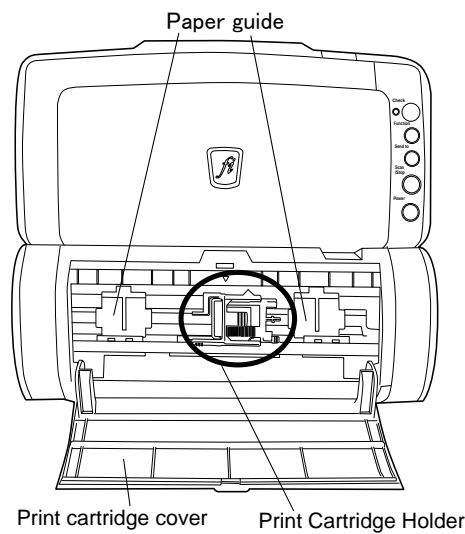

						TITLE	fi-6140/fi-6240/fi-6130/fi-6230/fi-614PR Maintenance Manual		
08	July 27, 09	K.Okada	A.Miyoshi	I.Fujioka	Refer to Revision Record on page 2.	DRAW	P1PA03540-B0XX/6	CUST.	
07	Nov.12, 08	K.Okada	T.Anzai	I.Fujioka	Refer to Revision Record on page 2.	No.			
06	Mar.10, 08	K.Okada	T.Anzai	I.Fujioka	Refer to Revision Record on page 2.				
Rev.	DATE	DESIGN	CHECK	APPR.	DESCRIPTION	PFU LIMITED		Page	196 / 257
Design	July 27, 2007	K.Okada	CHECK	K.Okada		APPR.	T.Anzai		

<Outer Dimensions>

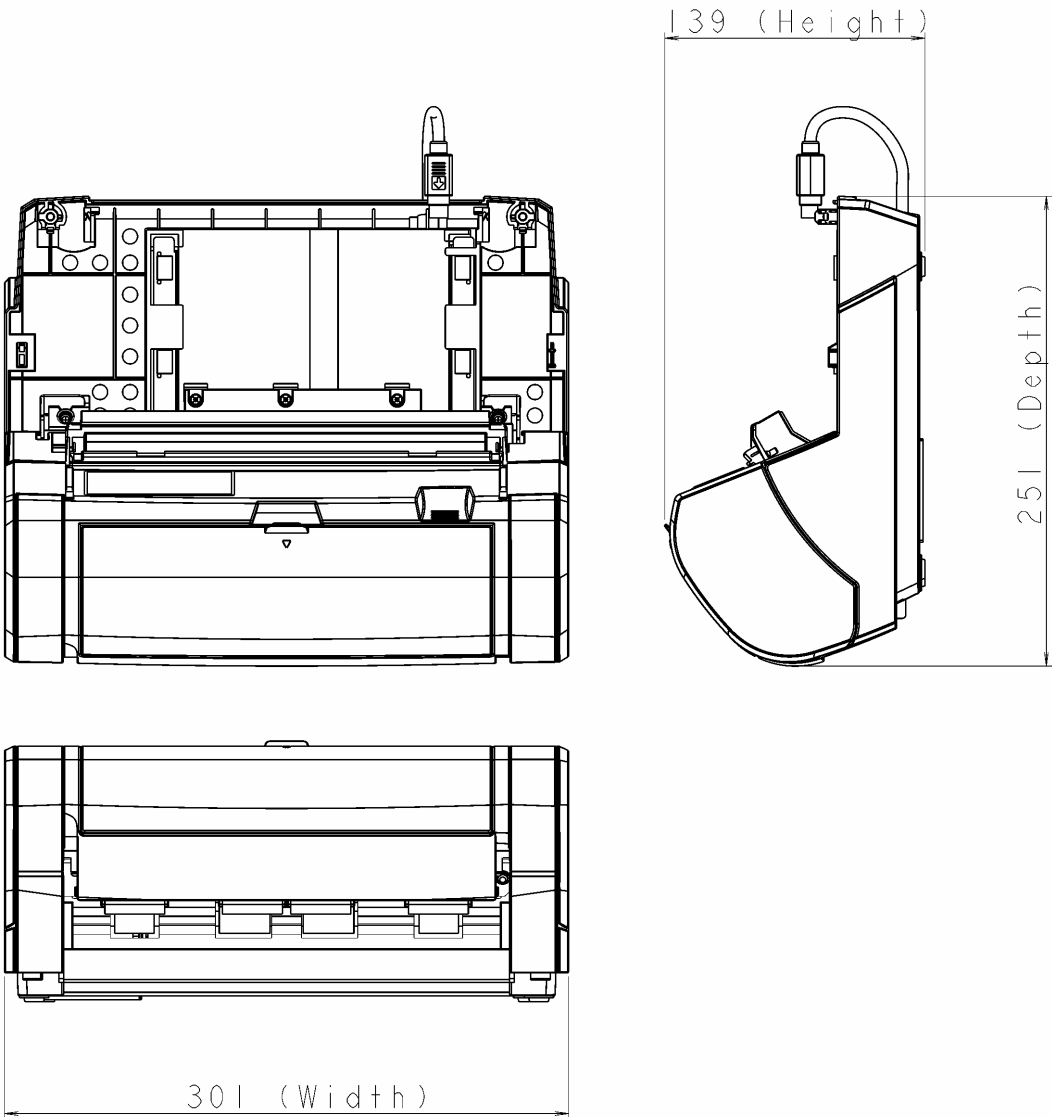

						TITLE	fi-6140/fi-6240/fi-6130/fi-6230/fi-614PR Maintenance Manual		
08	July 27, 09	K.Okada	A.Miyoshi	I.Fujioka	Refer to Revision Record on page 2.	DRAW No.	P1PA03540-B0XX/6	CUST.	
07	Nov.12, 08	K.Okada	T.Anzai	I.Fujioka	Refer to Revision Record on page 2.				
06	Mar.10, 08	K.Okada	T.Anzai	I.Fujioka	Refer to Revision Record on page 2.				
Rev.	DATE	DESIGN	CHECK	APPR.	DESCRIPTION	PFU LIMITED		Page	197 / 257
Design	July 27, 2007	K.Okada	CHECK	K.Okada		APPR.	T.Anzai		

8-1 Imprinter Operation

8-2-1 Imprinter Operation

(TBD)

When the scanner is powered ON, it investigates if the Imprinter EXT cable is connected to the scanner. If connected, the firmware judges that the imprinter is installed and drives Imprinter print head, sensor control, and transportation roller by the LF motor. The leading edge of the original fed from the ADF is detected by the Sensor and used for controlling the printing start timing. If the printing section is open, it is detected by the "ADF Cover Open Sensor" (See Section 8-4-12).

To avoid interference between the Imprinter printing section and the ADF cover, open the Imprinter printing section before opening the ADF cover. Follow the procedure in reverse when closing.

If the message to instruct to replace the print cartridge on the PC display, you need to replace the cartridge and reset the remaining ink counter (See Section 8-9-4).

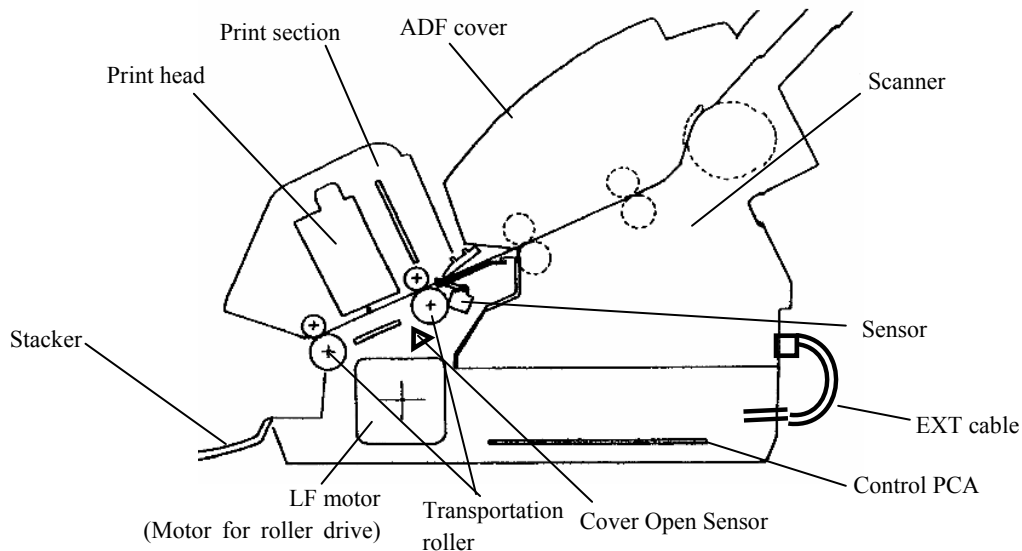

See the following sections for details of the errors and defects related to the Imprinter:

Errors and defects	Recovery method
J1: Paper jam	See Section 4-3-32.
U5: Imprinter Cover open	See Section 4-3-33.
U6: No print cartridge	See Section 4-3-35.
H6: Imprinter fuse blown	See Section 4-3-36
A0~A4: Imprinter alarm	See Section 4-3-37.
No initial operation	See Section 4-3-34.
Print-related errors	See Section 4-3-38.
	See Section 4-3-39.
	See Section 4-3-40.

Rev.	DATE	DESIGN	CHECK	APPR.	DESCRIPTION	TITLE	DRAW No.		CUST.
08	July 27, 09	K.Okada	A.Miyoshi	I.Fujioka	Refer to Revision Record on page 2.	fi-6140/fi-6240/fi-6130/fi-6230/fi-614PR Maintenance Manual	P1PA03540-B0XX/6		
07	Nov.12, 08	K.Okada	T.Anzai	I.Fujioka	Refer to Revision Record on page 2.				
06	Mar.10, 08	K.Okada	T.Anzai	I.Fujioka	Refer to Revision Record on page 2.				
Design	July 27, 2007	K.Okada	CHECK	K.Okada		PFU LIMITED	Page	198 / 257	

8-2-2 Circuit Block Diagram

The circuit block diagram of the Imprinter is as shown below.

Electric Component Block Diagram

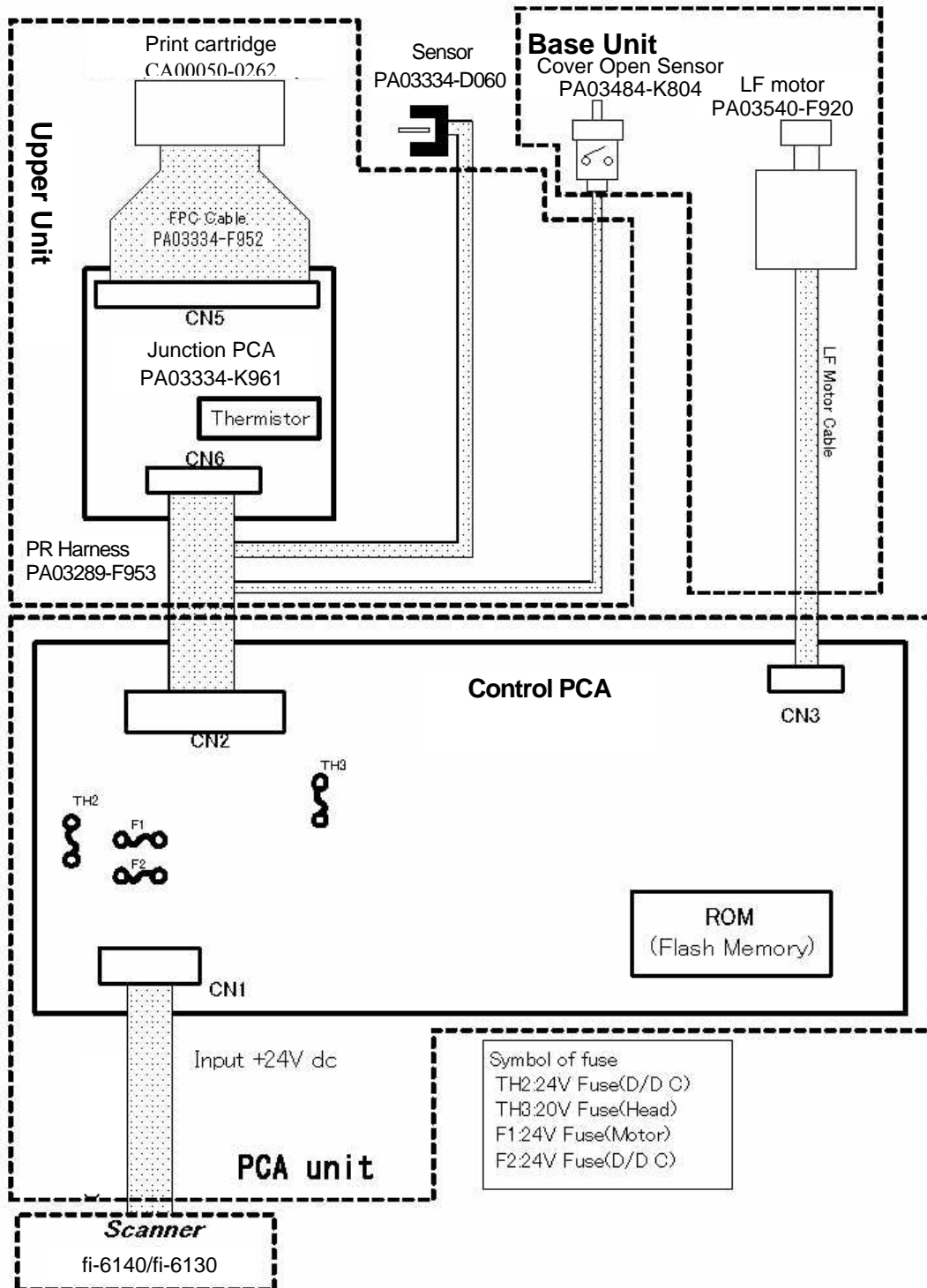

						TITLE	fi-6140/fi-6240/fi-6130/fi-6230/fi-614PR Maintenance Manual		
08	July 27, 09	K.Okada	A.Miyoshi	I.Fujioka	Refer to Revision Record on page 2.	DRAW	P1PA03540-B0XX/6	CUST.	
07	Nov.12, 08	K.Okada	T.Anzai	I.Fujioka	Refer to Revision Record on page 2.	No.			
06	Mar.10, 08	K.Okada	T.Anzai	I.Fujioka	Refer to Revision Record on page 2.				
Rev.	DATE	DESIGN	CHECK	APPR.	DESCRIPTION	PFU LIMITED		Page	199 / 257
Design	July 27, 2007	K.Okada	CHECK	K.Okada		APPR.	T.Anzai		

8-3 Unpacking and Installation of Imprinter

8-3-1 Unpacking the Imprinter

Follow the procedure below to unpack the Imprinter. Make sure that all the accessories are included in the package.

1. Remove the tape to open the package box.
2. Remove the accessories and the partition.
3. Remove the cushions TL/TR, then Imprinter.
4. Remove the imprinter from the polyethylene bag.
5. Remove the tape protecting the Imprinter.

The following table lists the packaging configuration.

No.	Items	Quantity	Remarks
1	Package box	1	
2	Cushion TL	1	
3	Cushion TR	1	
4	Cushion BL	1	
5	Cushion BR	1	
6	Partition	1	
7	Imprinter	1	
8	Print Cartridge	1	
9	Operator's Guide, Packaging list	1	

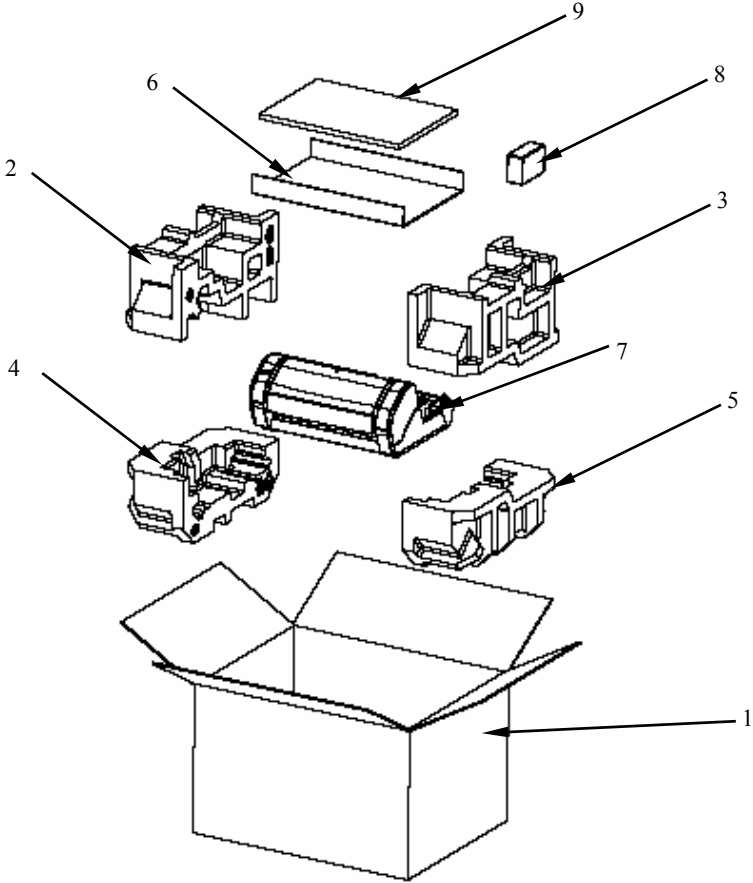

						TITLE	fi-6140/fi-6240/fi-6130/fi-6230/fi-614PR Maintenance Manual		
08	July 27, 09	K.Okada	A.Miyoshi	I.Fujioka	Refer to Revision Record on page 2.	DRAW	P1PA03540-B0XX/6	CUST.	
07	Nov.12, 08	K.Okada	T.Anzai	I.Fujioka	Refer to Revision Record on page 2.	No.			
06	Mar.10, 08	K.Okada	T.Anzai	I.Fujioka	Refer to Revision Record on page 2.				
Rev.	DATE	DESIGN	CHECK	APPR.	DESCRIPTION	PFU LIMITED		Page	200 / 257
Design	July 27, 2007	K.Okada	CHECK	K.Okada		APPR.	T.Anzai		

8-3-2 Installing the Imprinter

Install the Imprinter in the following procedure.

1. Press the  button to switch off the scanner and disconnect the AC cable.

2. Remove the stacker from the scanner.

- 1) Hold the left side of the stacker with left hand.
- 2) While pressing on the scanner with your thumb, pull the stacker gently away from the scanner.

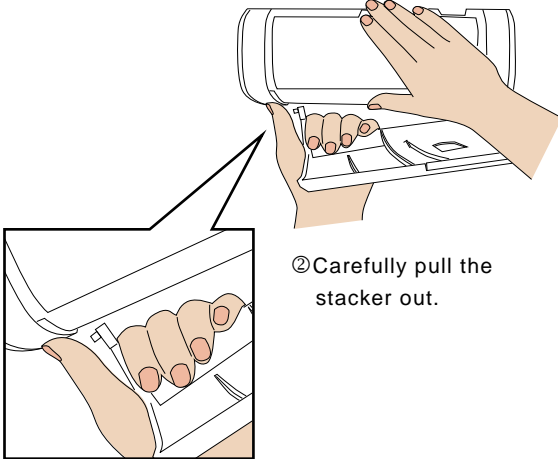
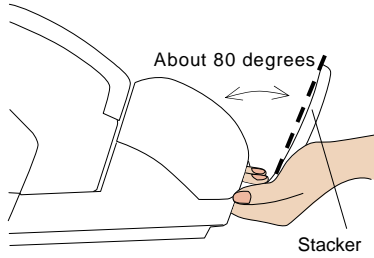

② Carefully pull the stacker out.

① Press your thumb on the scanner.

3) Once the left arm of the stacker has been released from the scanner, remove the right arm.

You must remove the stacker before installing the scanner to the Imprinter.

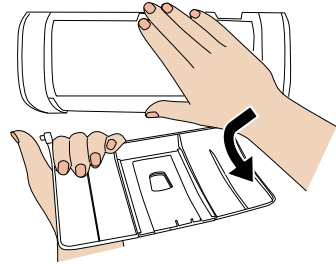

3. Install the scanner on to the Imprinter.

Holding the scanner above the rear side of the imprinter, gently mount the scanner onto the imprinter while lowering it forward until it makes contact with the imprinter.

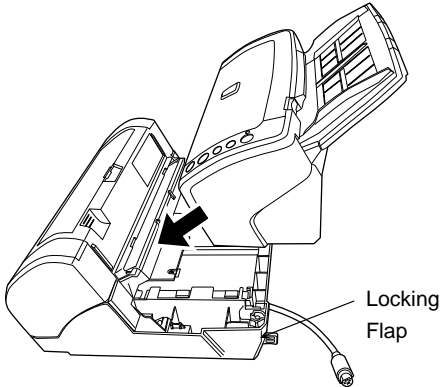

After installation

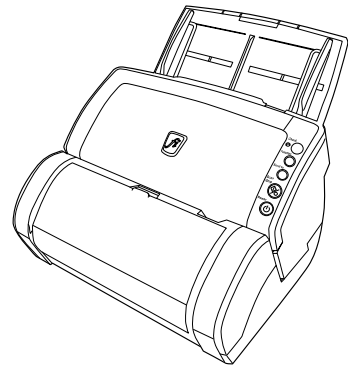
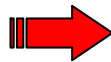

Take care not to pinch your fingers.

						TITLE	fi-6140/fi-6240/fi-6130/fi-6230/fi-614PR Maintenance Manual		
08	July 27, 09	K.Okada	A.Miyoshi	I.Fujioka	Refer to Revision Record on page 2.	DRAW	P1PA03540-B0XX/6	CUST.	
07	Nov.12, 08	K.Okada	T.Anzai	I.Fujioka	Refer to Revision Record on page 2.	No.			
06	Mar.10, 08	K.Okada	T.Anzai	I.Fujioka	Refer to Revision Record on page 2.				
Rev.	DATE	DESIGN	CHECK	APPR.	DESCRIPTION	PFU LIMITED		Page	201 / 257
Design	July 27, 2007	K.Okada	CHECK	K.Okada		APPR.	T.Anzai		

4. Raise the Locking Flaps (2 places on the rear).

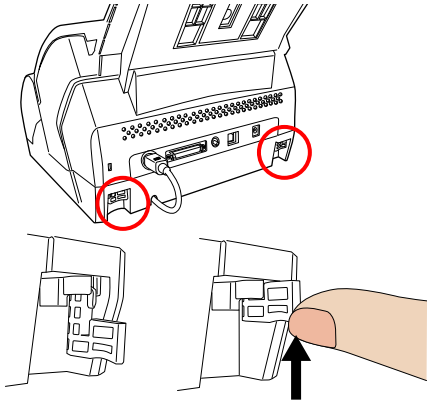

5. Swing the Locking Flaps inwards until they are locked into place.

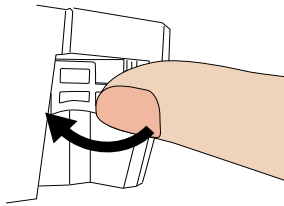

6. Connect the Imprinter cable (EXT cable) to the connector in the rear of the Scanner.

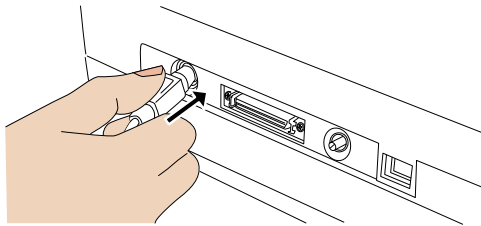

The Imprinter will not work if the EXT cable is not connected to the Scanner.
Scanning without the EXT cable connection can cause documents to jam inside the Imprinter.

7. Replace the stacker (removed in step 2) to the Imprinter.

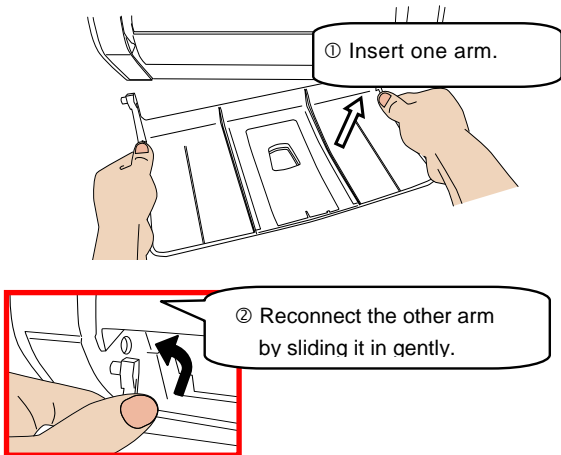

8. Connect the AC cable to the scanner.

						TITLE	fi-6140/fi-6240/fi-6130/fi-6230/fi-614PR Maintenance Manual		
08	July 27, 09	K.Okada	A.Miyoshi	I.Fujioka	Refer to Revision Record on page 2.	DRAW	P1PA03540-B0XX/6	CUST.	
07	Nov.12, 08	K.Okada	T.Anzai	I.Fujioka	Refer to Revision Record on page 2.	No.			
06	Mar.10, 08	K.Okada	T.Anzai	I.Fujioka	Refer to Revision Record on page 2.				
Rev.	DATE	DESIGN	CHECK	APPR.	DESCRIPTION	PFU LIMITED		Page	202 / 257
Design	July 27, 2007	K.Okada	CHECK	K.Okada		APPR.	T.Anzai		

8-3-3 Loading the Print cartridge

Load the Print cartridge as follows:

When installing or replacing the print cartridge, be careful not to insert it out of place.

1. Confirm that the scanner is turned OFF.
2. Open the Print Cartridge Cover by grasping its center and turning it towards you.
3. Remove the packing tape from the Print Cartridge Holder and the Paper Guides.
4. Open the Print Cartridge Holder by pinching and lifting up its locking lever with your fingers.

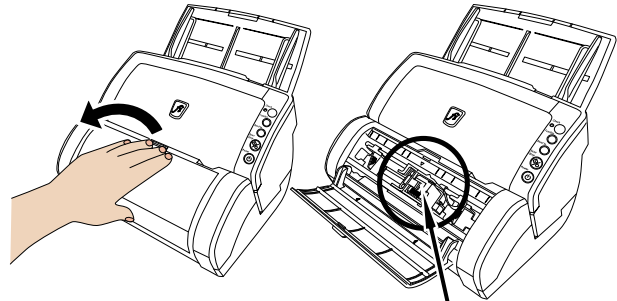

Print Cartridge Holder

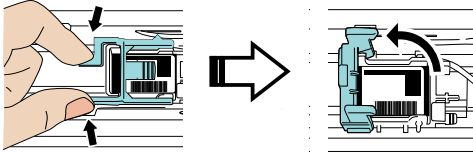

5. Remove the new print cartridge from its pouch.

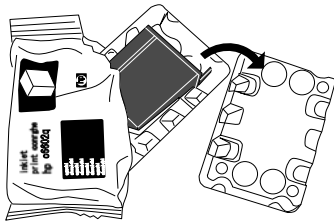

6. Remove the protection tape from the Print cartridge.

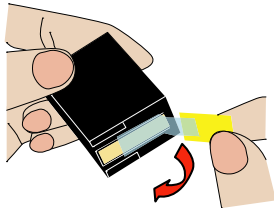

Do not touch the metal part of the cartridge nor put the tape back on again.

Rev.	DATE	DESIGN	CHECK	APPR.	DESCRIPTION	TITLE				
08	July 27, 09	K.Okada	A.Miyoshi	I.Fujioka	Refer to Revision Record on page 2.	fi-6140/fi-6240/fi-6130/fi-6230/fi-614PR Maintenance Manual				
07	Nov.12, 08	K.Okada	T.Anzai	I.Fujioka	Refer to Revision Record on page 2.	DRAW No.	P1PA03540-B0XX/6	CUST.		
06	Mar.10, 08	K.Okada	T.Anzai	I.Fujioka	Refer to Revision Record on page 2.					
Design	July 27, 2007	K.Okada	CHECK	K.Okada		APPR.	T.Anzai	PFU LIMITED	Page	203 / 257

- 7. Place the print cartridge into the holder as shown on the right with its tab positioning to the right.

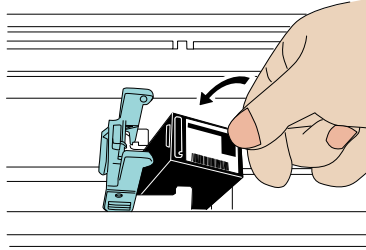

Be careful not let the print cartridge touch or catch onto the print circuit film.

- 8. Lower the locking lever of the Print Cartridge Holder until it locks in and fixes the cartridge in place.

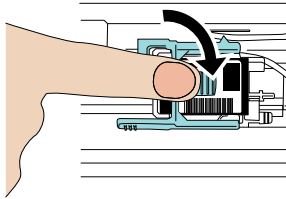

- 9. Position the Print Cartridge Holder along where the document will pass through.

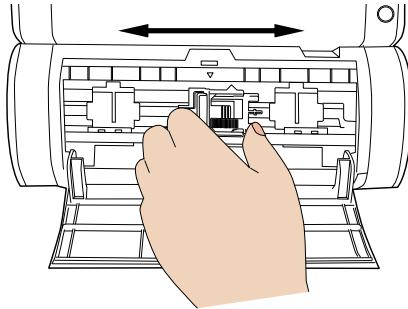

- 10. Close the Print Cartridge Cover.

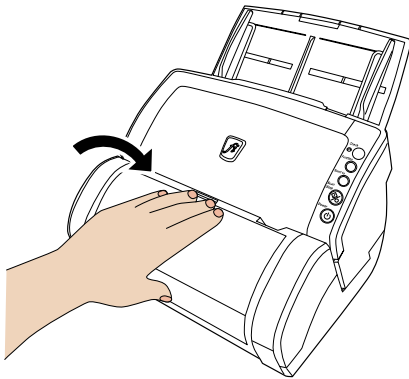

						TITLE	fi-6140/fi-6240/fi-6130/fi-6230/fi-614PR Maintenance Manual		
08	July 27, 09	K.Okada	A.Miyoshi	I.Fujioka	Refer to Revision Record on page 2.	DRAW	P1PA03540-B0XX/6	CUST.	
07	Nov.12, 08	K.Okada	T.Anzai	I.Fujioka	Refer to Revision Record on page 2.	No.			
06	Mar.10, 08	K.Okada	T.Anzai	I.Fujioka	Refer to Revision Record on page 2.				
Rev.	DATE	DESIGN	CHECK	APPR.	DESCRIPTION	PFU LIMITED		Page	204 / 257
Design	July 27, 2007	K.Okada	CHECK	K.Okada		APPR.	T.Anzai		

8-3-4 Operation Test

After installing the Imprinter, check if the printing operation can be done in the Offline Print Test mode of the scanner.

1. While holding down the **Function** button on the Operator Panel, press the **Power** button.

Keep the **Function** button pressed until the **Power** button is pressed.

2. Release the **Function** button when the Function Number Display changes from [P] to [b].

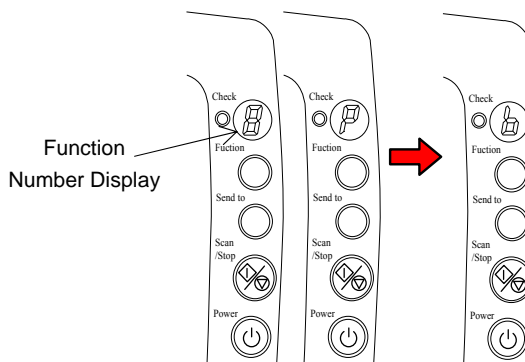

3. Place a blank paper into the ADF paper chute (Chuter Unit).

- Use A4 or Letter size paper. If the size is smaller than A4 or Letter,, printing may not complete successfully.
- Confirm that the Print cartridge is positioned within the paper width.

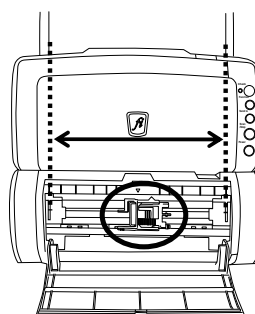

4. Press the **Scan/Stop** button to test.
 - => The paper will be fed into the ADF, and the Imprinter will print out the **Print Test Patterns** starting at 5mm from the paper edge (the range of error is ±4mm).

Print Test Patterns

- Test pattern 1 (horizontal):**
 ABCDEFGHIJKLMNOPQRSTUVWXYZ[¥]^_`00000000
- Test pattern 2 (horizontal):**
 abcdefghijklmnopqrstuvwxyz{|}~ 00000000
- Test pattern 3 (horizontal):**
 !"#%&()*+,-./0123456789:;<=>?@00000000
- Test pattern 4 (vertical):**
 ABCDEFGHIJKLMNOPQRSTUVWXYZ[¥]^_`00000000
- Test pattern 5 (vertical):**
 abcdefghijklmnopqrstuvwxyz{|}~ 00000000
- Test pattern 6 (vertical):**
 !"#%&()*+,-./0123456789:;<=>?@00000000

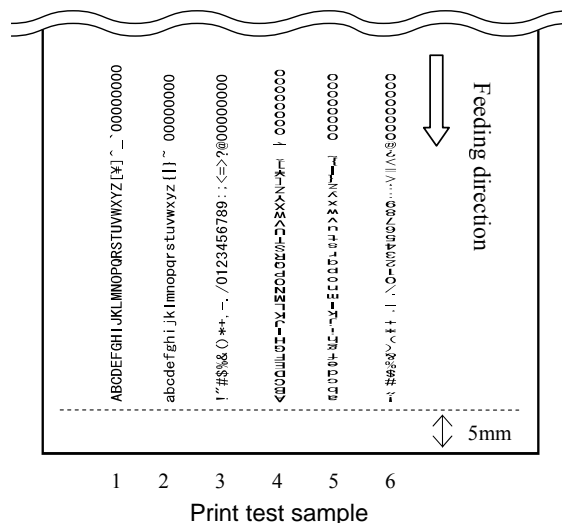

When multiple sheets of paper are placed in the ADF, the Test Print repeats patterns from 1 through 6. The numbering data portion "00000000" changes from 0 (Zero) with increment of 1 (one).

(One test pattern is printed at a time. Press the **Scan/Stop** button to continue printing the next test pattern.)

7. To stop Offline Print Test mode, press the **Power** button. The scanner will switch off.

						TITLE	fi-6140/fi-6240/fi-6130/fi-6230/fi-614PR		
08	July 27, 09	K.Okada	A.Miyoshi	I.Fujioka	Refer to Revision Record on page 2.		Maintenance Manual		
07	Nov.12, 08	K.Okada	T.Anzai	I.Fujioka	Refer to Revision Record on page 2.	DRAW	P1PA03540-B0XX/6		CUST.
06	Mar.10, 08	K.Okada	T.Anzai	I.Fujioka	Refer to Revision Record on page 2.	No.			
Rev.	DATE	DESIGN	CHECK	APPR.	DESCRIPTION	PFU LIMITED		Page	205 / 257
Design	July 27, 2007	K.Okada	CHECK	K.Okada		APPR.	T.Anzai		

8-4 Maintenance Parts for the Imprinter

POS	Description	Part Number	Quantity		Reference for appearance	Reference for replacement	Remarks
1	SENSOR	PA03334-D060	1		8-4-1	8-6-10	Shared with fi-512PR
2	IMP CT	PA03540-K926	1		8-4-2	8-6-9	
3	IMP JNT	PA03334-K961	1		8-4-3	8-6-7	Shared with fi-512PR
4	PR HARNESS	PA03289-F953	1		8-4-4	8-6-13	Shared with fi-512PR
5	IM FELT	PA03289-F954	1		8-4-5	8-6-14	Shared with fi-512PR
6	LF MOTOR	PA03540-F920	1		8-4-6	8-6-12	
7	IM HOLDER ASSY3	PA03540-E971	1		8-4-7	8-6-8	
8	IM HOLD LEVER3	PA03540-F922		1	8-4-8	8-6-5	
9	FPC CABLE	PA03334-F952		1	8-4-9	8-4-9	
10	IM PINCH ASSY3	PA03540-E970	4		8-4-10	8-6-6	
11	IM LOCK LEVER	PA03540-F921	2		8-4-11	8-6-15	
12	SWITCH	PA03484-K804	1		8-4-12	8-6-11	Cover open detection Shared with fi-6140/fi-6130.
13	GUIDE SHEET	PA03289-K910	1		8-4-13	8-6-16	Shared with fi-512PR
14	PAPER GUIDE3	PA03540-Y766	2		8-4-14	8-8-2	

						TITLE	fi-6140/fi-6240/fi-6130/fi-6230/fi-614PR Maintenance Manual	
08	July 27, 09	K.Okada	A.Miyoshi	I.Fujioka	Refer to Revision Record on page 2.	DRAW	P1PA03540-B0XX/6	CUST.
07	Nov.12, 08	K.Okada	T.Anzai	I.Fujioka	Refer to Revision Record on page 2.	No.		
06	Mar.10, 08	K.Okada	T.Anzai	I.Fujioka	Refer to Revision Record on page 2.			
Rev.	DATE	DESIGN	CHECK	APPR.	DESCRIPTION	PFU LIMITED		Page
Design	July 27, 2007	K.Okada	CHECK	K.Okada		APPR.	T.Anzai	206 / 257

8-4-1 SENSOR

Description	Parts No.	Remarks
SENSOR	PA03334-D060	Shared with fi-512PR.



8-4-2 IMP CT

Description	Parts No.	Remarks
IMP CT	PA03540-K926	PCA cover and cable is not included.

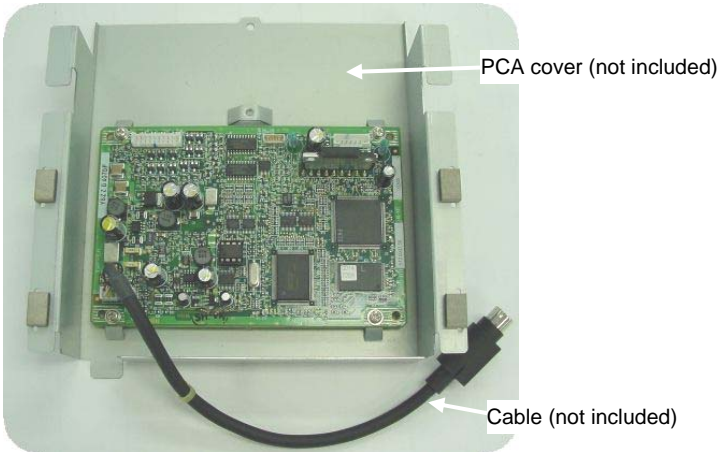

						TITLE	fi-6140/fi-6240/fi-6130/fi-6230/fi-614PR Maintenance Manual		
08	July 27, 09	K.Okada	A.Miyoshi	I.Fujioka	Refer to Revision Record on page 2.	DRAW No.	P1PA03540-B0XX/6	CUST.	
07	Nov.12, 08	K.Okada	T.Anzai	I.Fujioka	Refer to Revision Record on page 2.				
06	Mar.10, 08	K.Okada	T.Anzai	I.Fujioka	Refer to Revision Record on page 2.				
Rev.	DATE	DESIGN	CHECK	APPR.	DESCRIPTION	PFU LIMITED		Page	207 / 257
Design	July 27, 2007	K.Okada	CHECK	K.Okada		APPR.	T.Anzai		

8-4-3 IMP JNT

Description	Parts No.	Remarks
IMP JNT	PA03334-K961	Shared with fi-512PR.



8-4-4 PR HARNESS

Description	Parts No.	Remarks
PR HARNESS	PA03289-F953	Shared with fi-512PR.

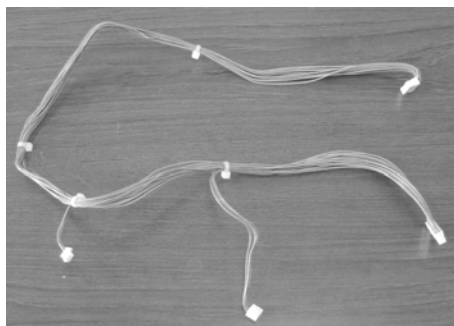

						TITLE	fi-6140/fi-6240/fi-6130/fi-6230/fi-614PR Maintenance Manual		
08	July 27, 09	K.Okada	A.Miyoshi	I.Fujioka	Refer to Revision Record on page 2.	DRAW No.	P1PA03540-B0XX/6	CUST.	
07	Nov.12, 08	K.Okada	T.Anzai	I.Fujioka	Refer to Revision Record on page 2.				
06	Mar.10, 08	K.Okada	T.Anzai	I.Fujioka	Refer to Revision Record on page 2.				
Rev.	DATE	DESIGN	CHECK	APPR.	DESCRIPTION	PFU LIMITED		Page	208 / 257
Design	July 27, 2007	K.Okada	CHECK	K.Okada		APPR.	T.Anzai		

8-4-5 IM FELT

Description	Parts No.	Remarks
IM FELT	PA03289-F954	Shared with fi-512PR.

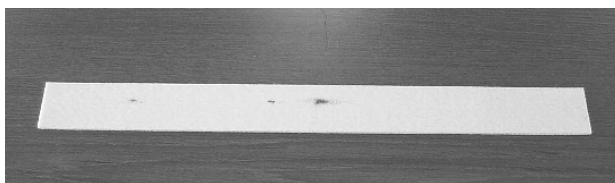

8-4-6 LF MOTOR

Description	Parts No.	Remarks
LF MOTOR	PA03540-F920	



						TITLE	fi-6140/fi-6240/fi-6130/fi-6230/fi-614PR Maintenance Manual		
08	July 27, 09	K.Okada	A.Miyoshi	I.Fujioka	Refer to Revision Record on page 2.	DRAW No.	P1PA03540-B0XX/6	CUST.	
07	Nov.12, 08	K.Okada	T.Anzai	I.Fujioka	Refer to Revision Record on page 2.				
06	Mar.10, 08	K.Okada	T.Anzai	I.Fujioka	Refer to Revision Record on page 2.				
Rev.	DATE	DESIGN	CHECK	APPR.	DESCRIPTION	PFU LIMITED		Page	209 / 257
Design	July 27, 2007	K.Okada	CHECK	K.Okada		APPR.	T.Anzai		

8-4-7 IM HOLDER ASSY3

Description	Parts No.	Remarks
IM HOLDER ASSY3	PA03540-E971	

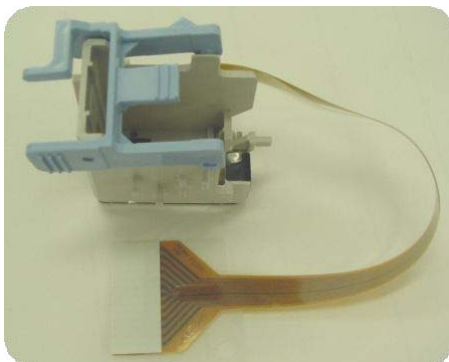

8-4-8 IM HOLD LEVER3

Description	Parts No.	Remarks
IM HOLD LEVER3	PA03540-F922	

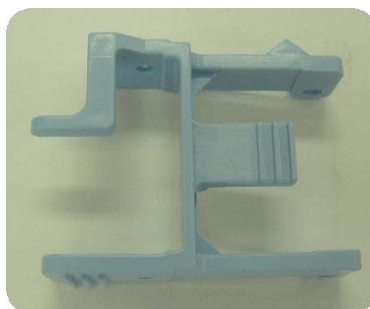

						TITLE	fi-6140/fi-6240/fi-6130/fi-6230/fi-614PR Maintenance Manual		
08	July 27, 09	K.Okada	A.Miyoshi	I.Fujioka	Refer to Revision Record on page 2.	DRAW No.	P1PA03540-B0XX/6	CUST.	
07	Nov.12, 08	K.Okada	T.Anzai	I.Fujioka	Refer to Revision Record on page 2.				
06	Mar.10, 08	K.Okada	T.Anzai	I.Fujioka	Refer to Revision Record on page 2.				
Rev.	DATE	DESIGN	CHECK	APPR.	DESCRIPTION	PFU LIMITED		Page	210 / 257
Design	July 27, 2007	K.Okada	CHECK	K.Okada		APPR.	T.Anzai		

8-4-9 FPC CABLE

Description	Parts No.	Remarks
FPC CABLE	PA03334-F952	

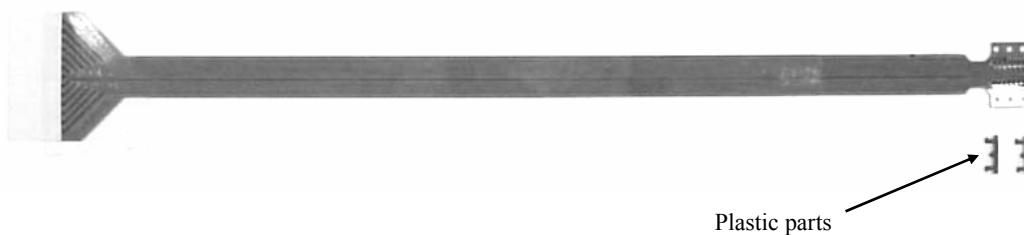

8-4-10 IM PINCH ASSY3

Description	Parts No.	Remarks
IM PINCH ASSY3	PA03540-E970	

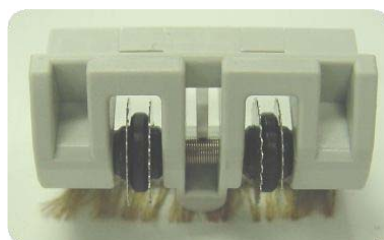

						TITLE	fi-6140/fi-6240/fi-6130/fi-6230/fi-614PR Maintenance Manual		
08	July 27, 09	K.Okada	A.Miyoshi	I.Fujioka	Refer to Revision Record on page 2.	DRAW No.	P1PA03540-B0XX/6	CUST.	
07	Nov.12, 08	K.Okada	T.Anzai	I.Fujioka	Refer to Revision Record on page 2.				
06	Mar.10, 08	K.Okada	T.Anzai	I.Fujioka	Refer to Revision Record on page 2.				
Rev.	DATE	DESIGN	CHECK	APPR.	DESCRIPTION	PFU LIMITED		Page	211 / 257
Design	July 27, 2007	K.Okada	CHECK	K.Okada		APPR.	T.Anzai		

8-4-11 IM LOCK LEVER

Description	Parts No.	Remarks
IM LOCK LEVER	PA03540-F921	



8-4-12 SWITCH (Cover open detection)

Description	Parts No.	Remarks
SWITCH	PA03484-K804	Shared with fi-6140/fi-6130



						TITLE	fi-6140/fi-6240/fi-6130/fi-6230/fi-614PR Maintenance Manual		
08	July 27, 09	K.Okada	A.Miyoshi	I.Fujioka	Refer to Revision Record on page 2.	DRAW No.	P1PA03540-B0XX/6	CUST.	
07	Nov.12, 08	K.Okada	T.Anzai	I.Fujioka	Refer to Revision Record on page 2.				
06	Mar.10, 08	K.Okada	T.Anzai	I.Fujioka	Refer to Revision Record on page 2.				
Rev.	DATE	DESIGN	CHECK	APPR.	DESCRIPTION	PFU LIMITED		Page	212 / 257
Design	July 27, 2007	K.Okada	CHECK	K.Okada		APPR.	T.Anzai		

8-4-13 GUIDE SHEET

Description	Parts No.	Remarks
GUIDE SHEET	PA03289-K910	Shared with fi-512PR

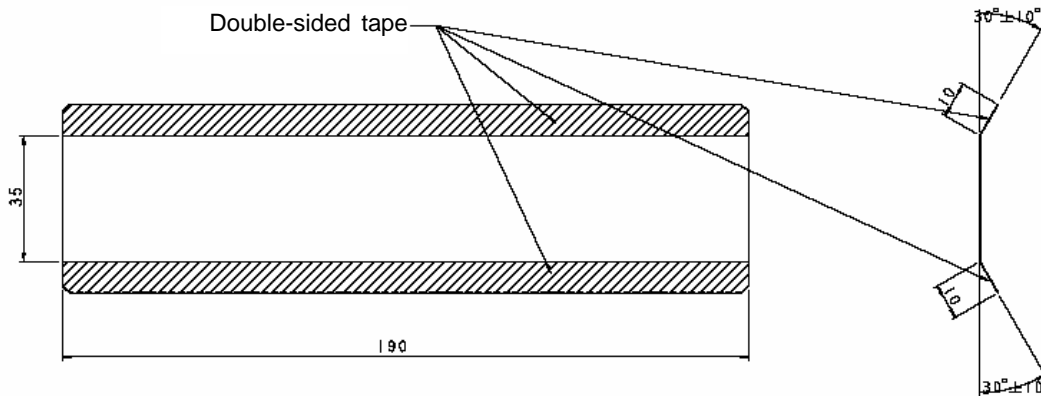

8-4-14 PAPER GUIDE3

Description	Parts No.	Remarks
PAPER GUIDE3	PA03540-Y766	



						TITLE	fi-6140/fi-6240/fi-6130/fi-6230/fi-614PR Maintenance Manual		
08	July 27, 09	K.Okada	A.Miyoshi	I.Fujioka	Refer to Revision Record on page 2.	DRAW No.	P1PA03540-B0XX/6	CUST.	
07	Nov.12, 08	K.Okada	T.Anzai	I.Fujioka	Refer to Revision Record on page 2.				
06	Mar.10, 08	K.Okada	T.Anzai	I.Fujioka	Refer to Revision Record on page 2.				
Rev.	DATE	DESIGN	CHECK	APPR.	DESCRIPTION	PFU LIMITED		Page	213 / 257
Design	July 27, 2007	K.Okada	CHECK	K.Okada					

8-5 Troubleshooting

See Chapter 4 “Troubleshooting.”

						TITLE	fi-6140/fi-6240/fi-6130/fi-6230/fi-614PR Maintenance Manual		
08	July 27, 09	K.Okada	A.Miyoshi	I.Fujioka	Refer to Revision Record on page 2.	DRAW No.	P1PA03540-B0XX/6	CUST.	
07	Nov.12, 08	K.Okada	T.Anzai	I.Fujioka	Refer to Revision Record on page 2.				
06	Mar.10, 08	K.Okada	T.Anzai	I.Fujioka	Refer to Revision Record on page 2.				
Rev.	DATE	DESIGN	CHECK	APPR.	DESCRIPTION	PFU LIMITED		Page	214 / 257
Design	July 27, 2007	K.Okada	CHECK	K.Okada		APPR.	T.Anzai		

8-6 Disassembly/Assembly

This chapter describes warning and cautions, how to remove or replace covers and maintenance parts for the Imprinter to ensure the normal operations.

8-6-1 For Safety operation

Preventative maintenance is recommended on the Imprinter at the following intervals.

- Every 12 month, or at the periodic maintenance of the connected scanner

Notes at replacement work

- Clean the place where replacement work is conducted.
- Be sure to follow the described procedures. Never loosen the non-disassembly screws.
- Avoid loss of the removed parts.
- Check the quantities and shapes of the parts after replacement.
- Follow the removal procedure in reverse for the installation procedure.

CAUTION

Machine damage

Static Electricity charged human body due to rubbed clothes may cause the damage of electric element.

When repairing the substrate as a System Board or a Main Control Board, put a wrist strap or use a conductive mat to avoid ESD.

Injury

Be careful not to get your fingers, hair, clothes or accessories caught in a moving part. It may cause injury.

- Perform the periodic maintenance at the same time when it is performed for the image scanner.
- Refer to Section 8-9 "Daily Care" for how to clean in detail.

8-6-2 Maintenance tool

Special tools to maintain this Imprinter are shown in the table below.

No.	Tools	Remarks	When to use
1	Phillips screwdriver	M3, M4 screws	
2	Small flat-blade screwdriver		Removing E ring, lever switch
3	Plier		Removing clamps
4	Alcohol	Ethyl alcohol	Cleaning
5	Spring gauge	500g	Adjusting belt tension

8-6-3 (Reserved)

Rev.	DATE	DESIGN	CHECK	APPR.	DESCRIPTION	TITLE	DRAW No.		CUST.
08	July 27, 09	K.Okada	A.Miyoshi	I.Fujioka	Refer to Revision Record on page 2.	fi-6140/fi-6240/fi-6130/fi-6230/fi-614PR Maintenance Manual	P1PA03540-B0XX/6		
07	Nov.12, 08	K.Okada	T.Anzai	I.Fujioka	Refer to Revision Record on page 2.				
06	Mar.10, 08	K.Okada	T.Anzai	I.Fujioka	Refer to Revision Record on page 2.				
Design	July 27, 2007	K.Okada	CHECK	K.Okada		PFU LIMITED	Page	215 / 257	

8-6-4 Removing Imprinter

<Removal>

1. Remove the Imprinter.

- (1) - Remove the EXT cable.
 - Pull two IM LOCK LEVERs (circles below) to the rear side of the scanner to remove.

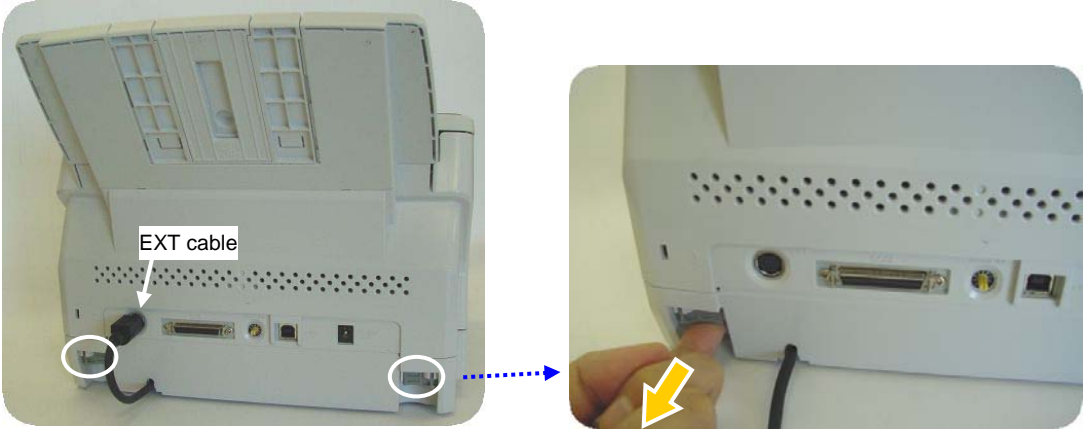

- (2) Lift up the scanner diagonally backward to remove.

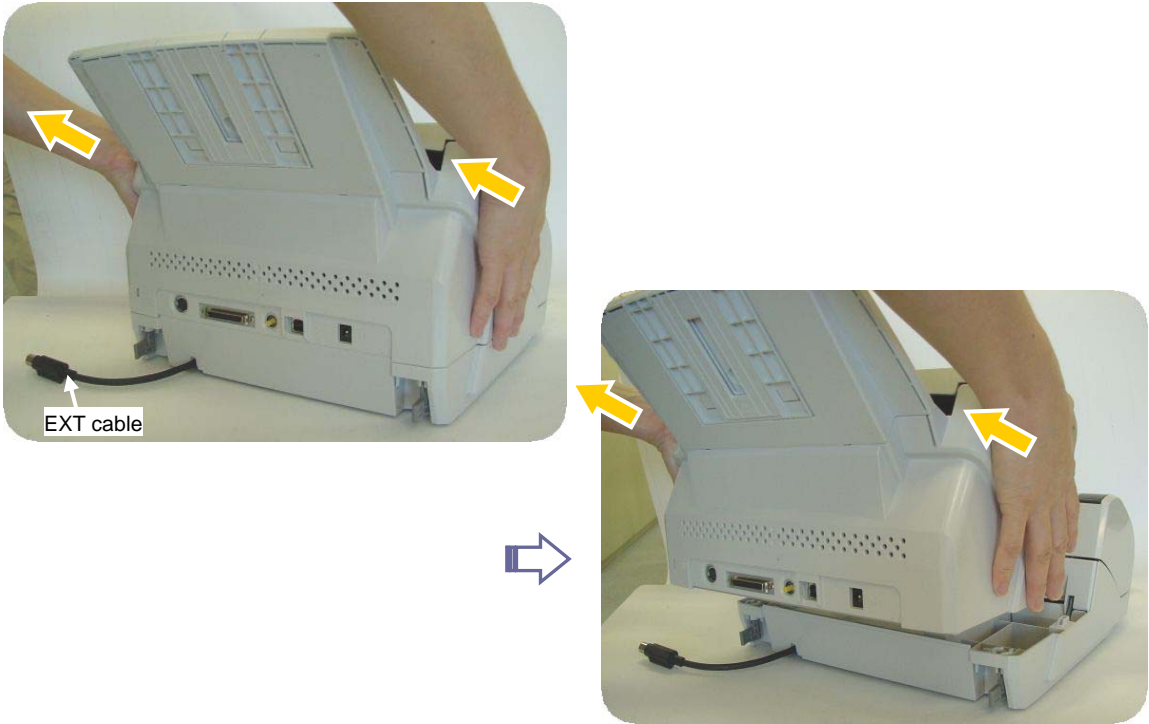

						TITLE	fi-6140/fi-6240/fi-6130/fi-6230/fi-614PR Maintenance Manual		
08	July 27, 09	K.Okada	A.Miyoshi	I.Fujioka	Refer to Revision Record on page 2.	DRAW	P1PA03540-B0XX/6	CUST.	
07	Nov.12, 08	K.Okada	T.Anzai	I.Fujioka	Refer to Revision Record on page 2.	No.			
06	Mar.10, 08	K.Okada	T.Anzai	I.Fujioka	Refer to Revision Record on page 2.				
Rev.	DATE	DESIGN	CHECK	APPR.	DESCRIPTION	PFU LIMITED		Page	216 / 257
Design	July 27, 2007	K.Okada	CHECK	K.Okada		APPR.	T.Anzai		

8-6-5 IM HOLD LEVER3

NOTICE

- Refer to Section 8-4-8 for the part number of the replacement part.

<Removal>

1. Remove the Print Cartridge.

(1) Referring to steps (1) ~ (4) of Section 8-9-4 “Replacing the Print Cartridge,” remove the print cartridge.

2. Remove the IM HOLD LEVER3.

(2) Pinching the right side of the IM HOLD LEVER3 **1**, open the fulcrum (circle below) at the lower left **2**, remove the IM HOLD LEVER3.

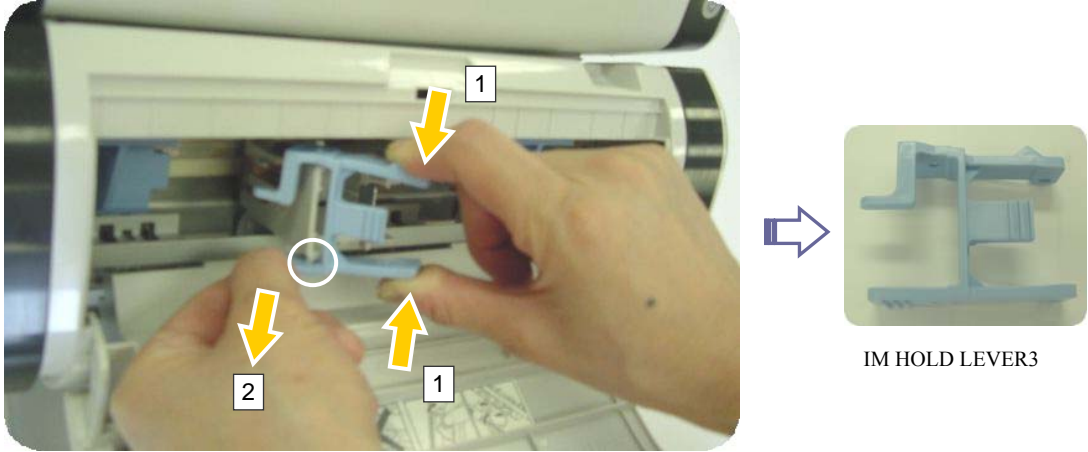

IM HOLD LEVER3

<Installation>

Follow the removing procedure in reverse.

						TITLE	fi-6140/fi-6240/fi-6130/fi-6230/fi-614PR Maintenance Manual		
08	July 27, 09	K.Okada	A.Miyoshi	I.Fujioka	Refer to Revision Record on page 2.	DRAW No.	P1PA03540-B0XX/6	CUST.	
07	Nov.12, 08	K.Okada	T.Anzai	I.Fujioka	Refer to Revision Record on page 2.				
06	Mar.10, 08	K.Okada	T.Anzai	I.Fujioka	Refer to Revision Record on page 2.				
Rev.	DATE	DESIGN	CHECK	APPR.	DESCRIPTION	PFU LIMITED		Page	217 / 257
Design	July 27, 2007	K.Okada	CHECK	K.Okada		APPR.	T.Anzai		

8-6-6 IM PINCH ASSY3

NOTICE

- Refer to Section 8-4-10 for the part number of the replacement part.
- Refer to Appendix for the specification of the screws.

<Removal>

1. Remove the Imprinter.

(1) Referring to Section 8-6-4 “Removing Imprinter,” remove the Imprinter.

2. Remove the IM PINCH ASSY3.

(2) Open the Print section in the direction of the arrow.

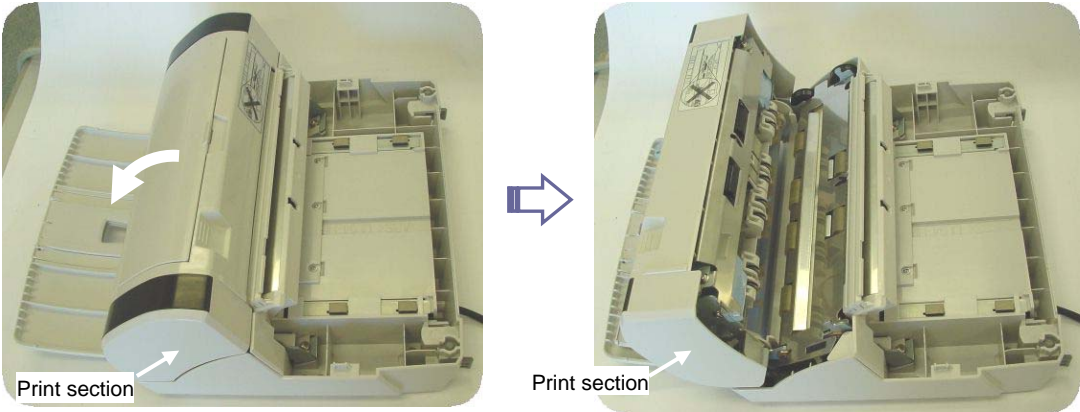

(3) Remove two screws A (circles below) on the Print section.



						TITLE	fi-6140/fi-6240/fi-6130/fi-6230/fi-614PR Maintenance Manual		
08	July 27, 09	K.Okada	A.Miyoshi	I.Fujioka	Refer to Revision Record on page 2.	DRAW No.	P1PA03540-B0XX/6		CUST.
07	Nov.12, 08	K.Okada	T.Anzai	I.Fujioka	Refer to Revision Record on page 2.				
06	Mar.10, 08	K.Okada	T.Anzai	I.Fujioka	Refer to Revision Record on page 2.				
Rev.	DATE	DESIGN	CHECK	APPR.	DESCRIPTION	PFU LIMITED		Page	218 / 257
Design	July 27, 2007	K.Okada	CHECK	K.Okada		APPR.	T.Anzai		

(4) Remove the Print section cover in the direction of the arrow.

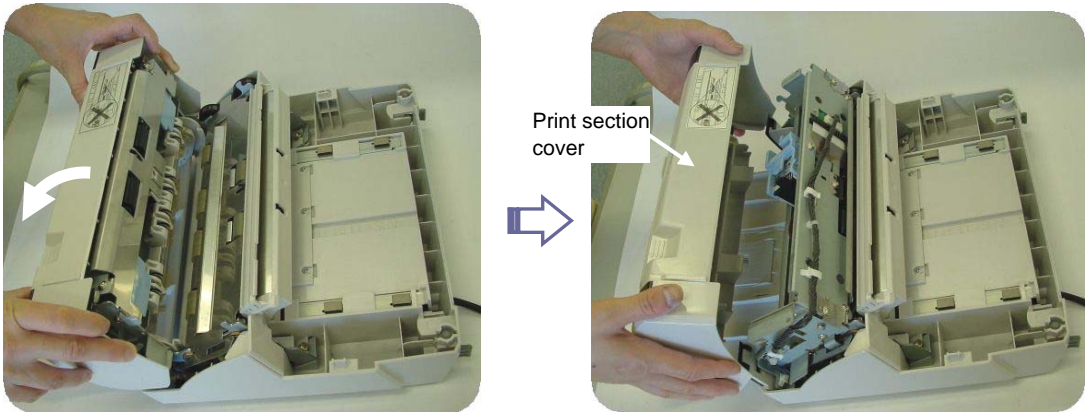

(5) Remove four screws A (circles below) on the IM PINCH ASY3 from outside of the Print section.

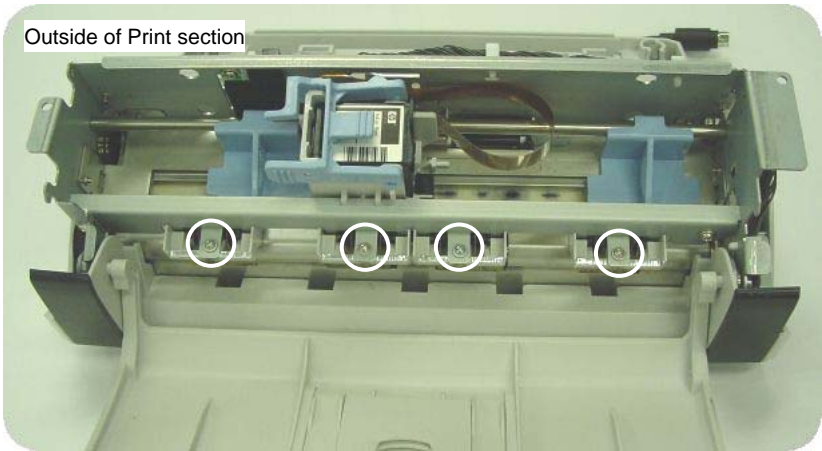

(6) Remove four screws (circles below) on the IM PINCH ASY3 from inside of the Print section.

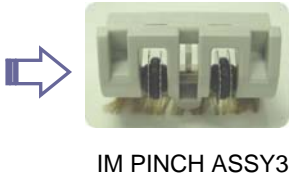
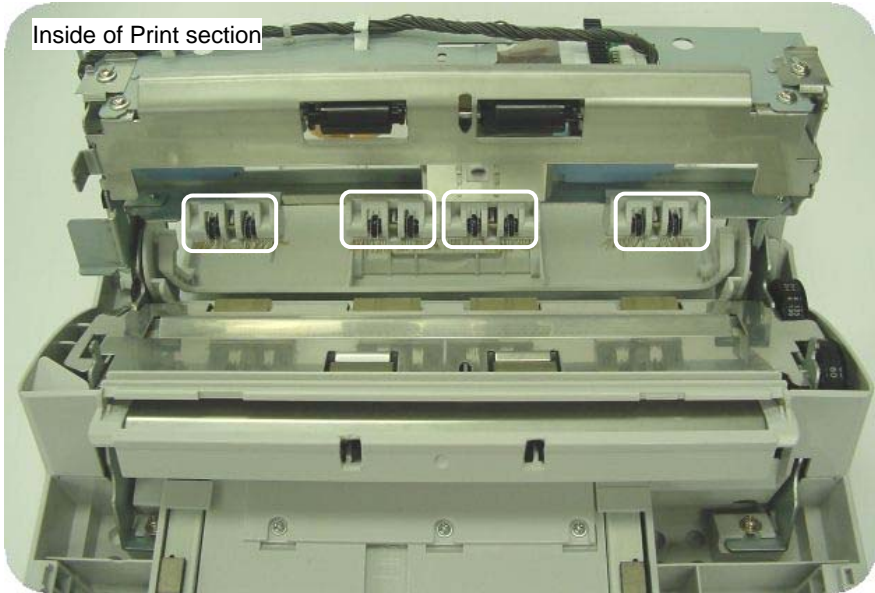

IM PINCH ASSY3

						TITLE	fi-6140/fi-6240/fi-6130/fi-6230/fi-614PR Maintenance Manual		
08	July 27, 09	K.Okada	A.Miyoshi	I.Fujioka	Refer to Revision Record on page 2.	DRAW	P1PA03540-B0XX/6	CUST.	
07	Nov.12, 08	K.Okada	T.Anzai	I.Fujioka	Refer to Revision Record on page 2.	No.			
06	Mar.10, 08	K.Okada	T.Anzai	I.Fujioka	Refer to Revision Record on page 2.				
Rev.	DATE	DESIGN	CHECK	APPR.	DESCRIPTION	PFU LIMITED		Page	219 / 257
Design	July 27, 2007	K.Okada	CHECK	K.Okada		APPR.	T.Anzai		

<Installation>

Follow the removing procedure in reverse.

Check that two tabs (circles below) of the Print section are engaged.



						TITLE	fi-6140/fi-6240/fi-6130/fi-6230/fi-614PR Maintenance Manual		
08	July 27, 09	K.Okada	A.Miyoshi	I.Fujioka	Refer to Revision Record on page 2.	DRAW No.	P1PA03540-B0XX/6	CUST.	
07	Nov.12, 08	K.Okada	T.Anzai	I.Fujioka	Refer to Revision Record on page 2.				
06	Mar.10, 08	K.Okada	T.Anzai	I.Fujioka	Refer to Revision Record on page 2.				
Rev.	DATE	DESIGN	CHECK	APPR.	DESCRIPTION	PFU LIMITED		Page	220 / 257
Design	July 27, 2007	K.Okada	CHECK	K.Okada					

8-6-7 IMP JNT

NOTICE

- Refer to Section 8-4-3 for the part number of the replacement part.
- Refer to Appendix for the specification of the screws.

<Removal>

1. Remove the Imprinter.

(1) Referring to Section 8-6-4 “Removing Imprinter,” remove the Imprinter.

2. Remove the Print section cover.

(2) Referring to steps (2) ~ (4) of Section 8-6-6 “IM PINCH ASSY3,” remove the Print section cover.

3. Remove the IMP JNT.

(3) - Disconnect the PR HARNESS from the IMP JNT.

- Remove the screw B (circle below) of the FPC CABLE (plastic), and then disconnect the FPC CABLE from the IMP JNT.

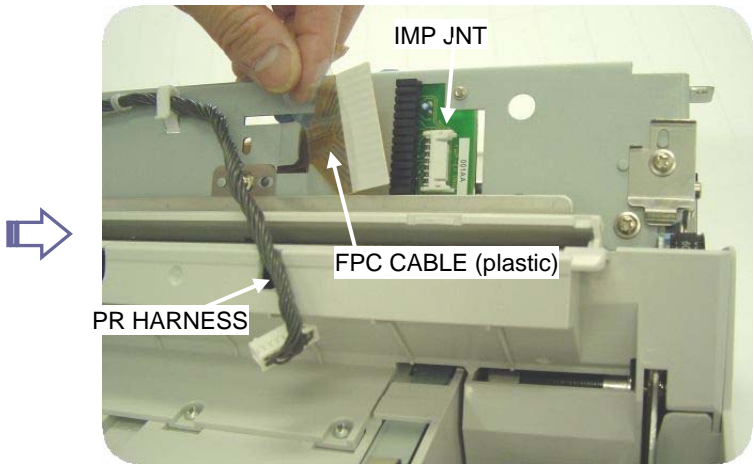
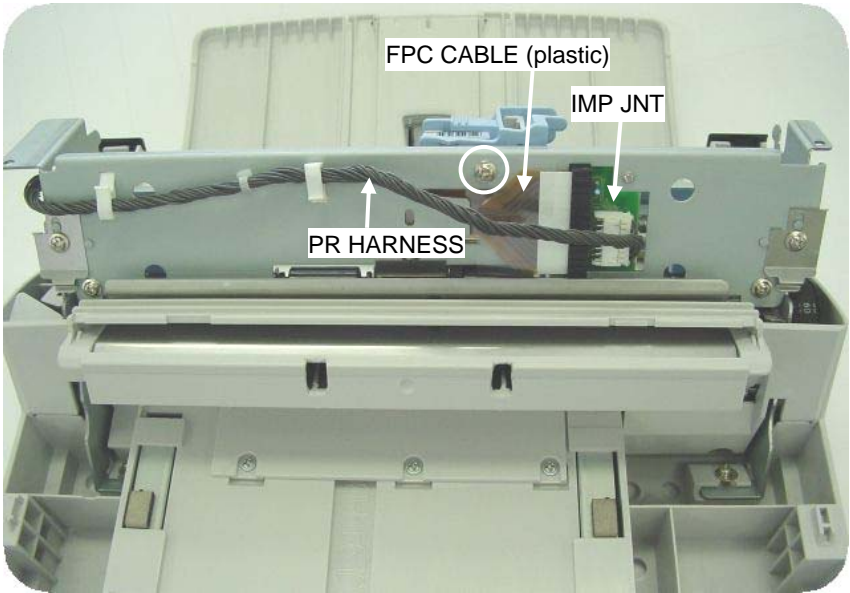

						TITLE	fi-6140/fi-6240/fi-6130/fi-6230/fi-614PR Maintenance Manual		
08	July 27, 09	K.Okada	A.Miyoshi	I.Fujioka	Refer to Revision Record on page 2.	DRAW	P1PA03540-B0XX/6	CUST.	
07	Nov.12, 08	K.Okada	T.Anzai	I.Fujioka	Refer to Revision Record on page 2.	No.			
06	Mar.10, 08	K.Okada	T.Anzai	I.Fujioka	Refer to Revision Record on page 2.				
Rev.	DATE	DESIGN	CHECK	APPR.	DESCRIPTION	PFU LIMITED		Page	221 / 257
Design	July 27, 2007	K.Okada	CHECK	K.Okada		APPR.	T.Anzai		

(4) Remove the screw B (circle below) of the IMP JNT to remove the IMP JNT.

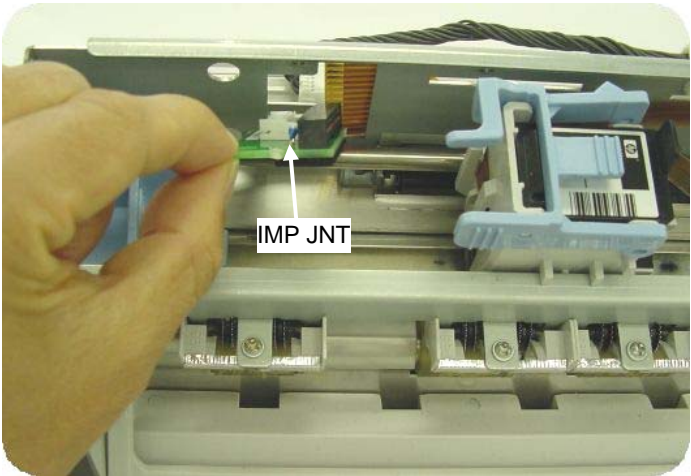
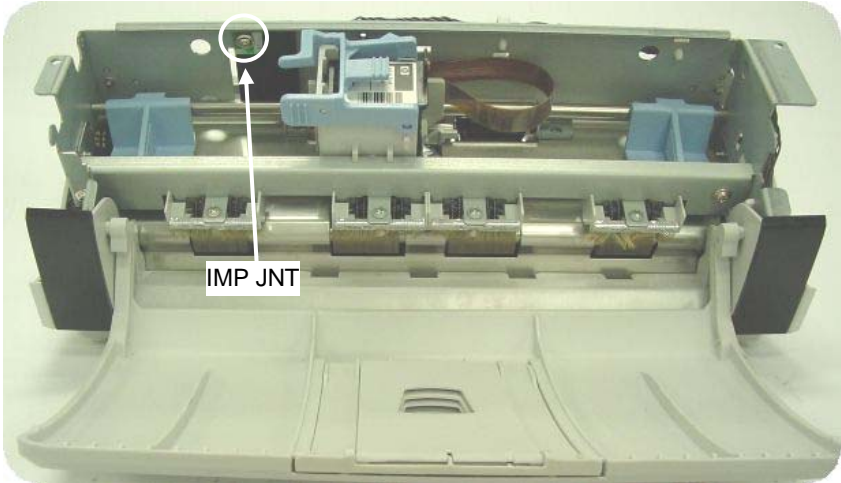

<Installation>

Follow the removing procedure in reverse.

						TITLE	fi-6140/fi-6240/fi-6130/fi-6230/fi-614PR Maintenance Manual		
08	July 27, 09	K.Okada	A.Miyoshi	I.Fujioka	Refer to Revision Record on page 2.	DRAW No.	P1PA03540-B0XX/6	CUST.	
07	Nov.12, 08	K.Okada	T.Anzai	I.Fujioka	Refer to Revision Record on page 2.				
06	Mar.10, 08	K.Okada	T.Anzai	I.Fujioka	Refer to Revision Record on page 2.				
Rev.	DATE	DESIGN	CHECK	APPR.	DESCRIPTION	PFU LIMITED		Page	222 / 257
Design	July 27, 2007	K.Okada	CHECK	K.Okada		APPR.	T.Anzai		

8-6-8 IM HOLDER ASSY3/FPC CABLE

NOTICE

- Refer to Section 8-4-7 for the part number of the IM HOLDER ASSY3.
- Refer to Section 8-4-9 for the part number of the FPC CABLE.

<Removal-IM HOLDER ASSY3>

1. Remove the Imprinter.

(1) Referring to Section 8-6-4 “Removing Imprinter,” remove the Imprinter.

2. Remove the Print section cover.

(2) Referring to steps (2) ~ (4) of Section 8-6-6 “IM PINCH ASSY3,” remove the Print section cover.

3. Remove the PR HARNESS and FPC CABLE (plastic).

(3) Referring to step (3) of Section 8-6-7 “IMP JNT,” disconnect the PR HARNESS and FPC CABLE.

4. Remove the IM HOLDER ASSY3.

(4) - Pull the FPC CABLE (plastic) out of the opening on the frame, and withdraw it to the IM HOLDER ASSY3 side. **1**

- Remove the E-ring (circle below) on the IM HOLDER ASSY3 shaft. **2**

- Disconnect the IM HOLDER ASSY3 shaft in the direction of the arrow, and then remove the IM HOLDER ASSY3. **3**

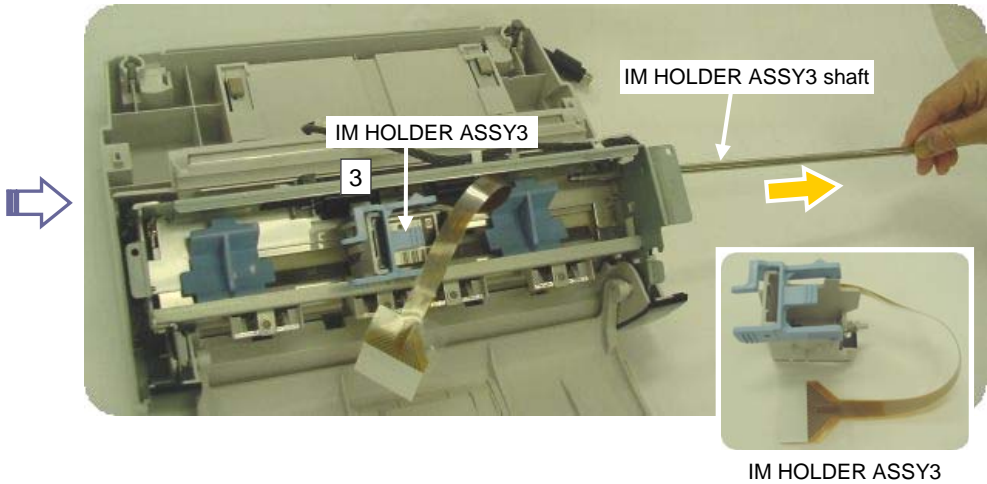
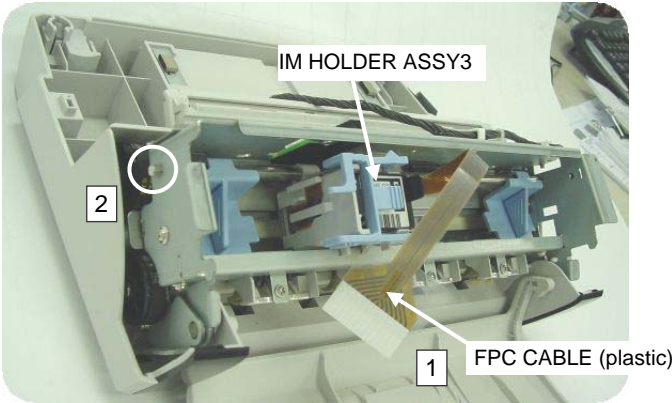

* To remove the FPC CABLE, go to next page.

<Installation-FPC CABLE>

Follow the removing procedure in reverse.

						TITLE	fi-6140/fi-6240/fi-6130/fi-6230/fi-614PR Maintenance Manual		
08	July 27, 09	K.Okada	A.Miyoshi	I.Fujioka	Refer to Revision Record on page 2.	DRAW No.	P1PA03540-B0XX/6	CUST.	
07	Nov.12, 08	K.Okada	T.Anzai	I.Fujioka	Refer to Revision Record on page 2.				
06	Mar.10, 08	K.Okada	T.Anzai	I.Fujioka	Refer to Revision Record on page 2.				
Rev.	DATE	DESIGN	CHECK	APPR.	DESCRIPTION	PFU LIMITED		Page	223 / 257
Design	July 27, 2007	K.Okada	CHECK	K.Okada		APPR.	T.Anzai		

<Removal-FPC CABLE>

(5) Remove two plastic parts from the Holder with a flat-blade screwdriver.

Be careful not to lose the rubber cushions at the bottom of the Holder.

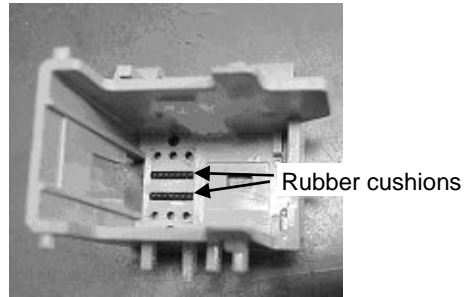
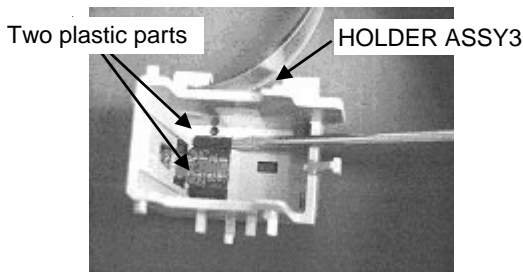

(6) Remove one end of the FPC CABLE from the HOLDER.

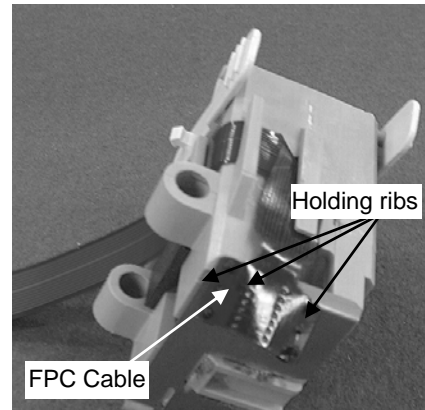
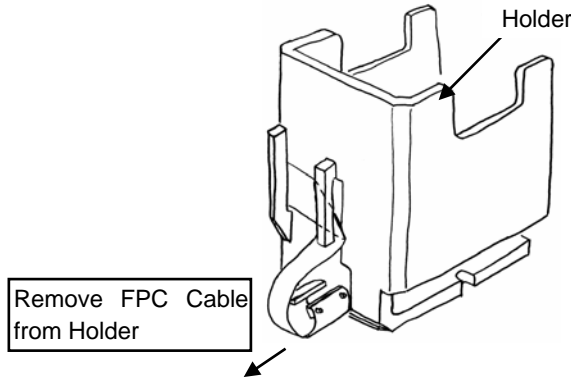

(7) Withdraw the FPC CABLE from all the cable holding ribs.

<Installation-FPC CABLE>

Follow the removing procedure in reverse by taking care of the following point.

1. Fold the new FPC Cable as shown in the right figure.
2. Small plastic parts come with the FPC Cable. Insert two small plastic parts into the holes of the FPC Cable near electrodes.

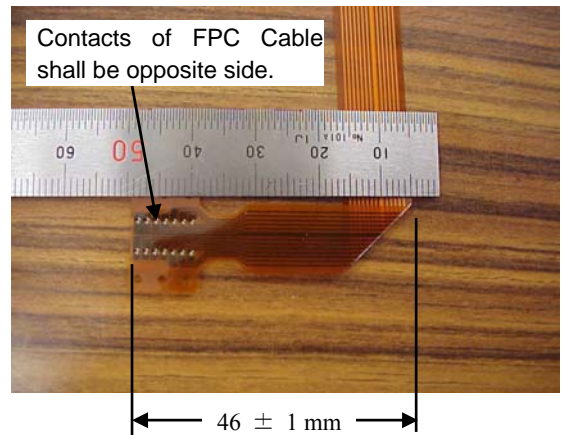
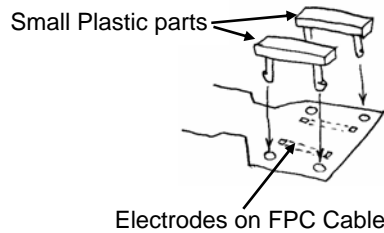

3. Route the new FPC Cable as shown in the following figure.

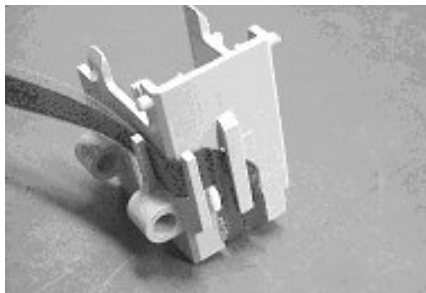

						TITLE	fi-6140/fi-6240/fi-6130/fi-6230/fi-614PR Maintenance Manual		
08	July 27, 09	K.Okada	A.Miyoshi	I.Fujioka	Refer to Revision Record on page 2.	DRAW No.	P1PA03540-B0XX/6		CUST.
07	Nov.12, 08	K.Okada	T.Anzai	I.Fujioka	Refer to Revision Record on page 2.				
06	Mar.10, 08	K.Okada	T.Anzai	I.Fujioka	Refer to Revision Record on page 2.				
Rev.	DATE	DESIGN	CHECK	APPR.	DESCRIPTION	PFU LIMITED		Page	224 / 257
Design	July 27, 2007	K.Okada	CHECK	K.Okada		APPR.	T.Anzai		

8-6-9 IMP CT

NOTICE

- Refer to Section 8-4-2 for the part number of the maintenance part.
- Refer to Appendix for the specification of the screws.

<Removal>

1. Remove the Imprinter.

(1) Referring to Section 8-6-4 “Removing Imprinter,” remove the Imprinter.

2. Remove the IMP CT.

- (2) - Remove the screw A (circle below) at the bottom of the Imprinter.
- Move the PCA cover downward **1**, and then lift up its upper side to remove **2**.

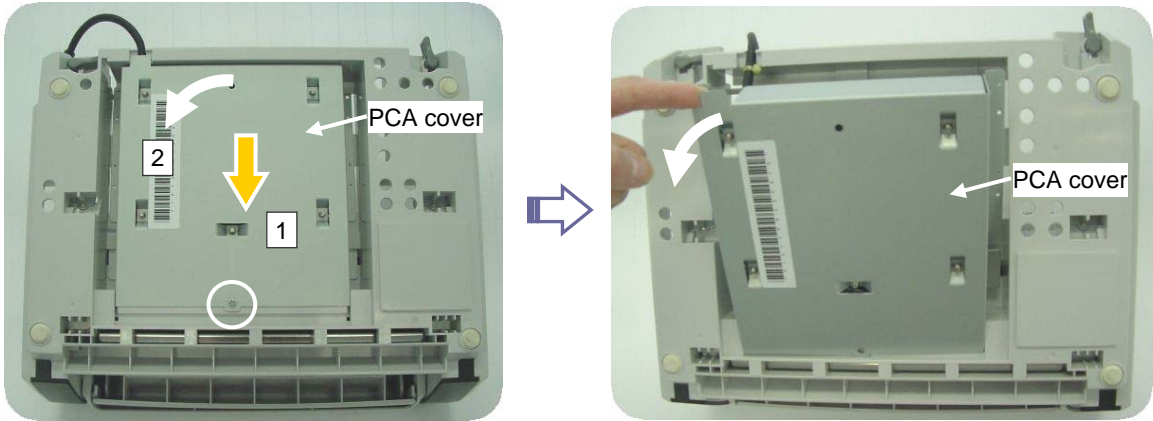

(3) Remove the fixing screw C (circle below) and two connectors (squares below).

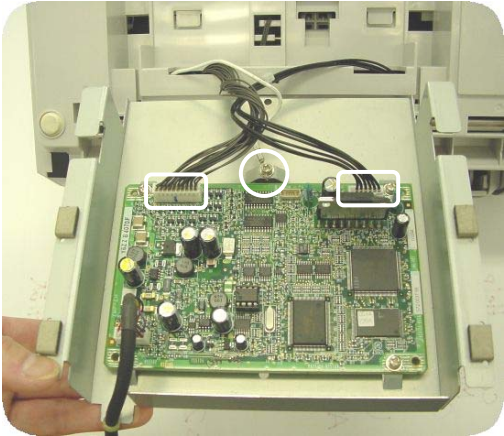

						TITLE	fi-6140/fi-6240/fi-6130/fi-6230/fi-614PR Maintenance Manual		
08	July 27, 09	K.Okada	A.Miyoshi	I.Fujioka	Refer to Revision Record on page 2.	DRAW	P1PA03540-B0XX/6	CUST.	
07	Nov.12, 08	K.Okada	T.Anzai	I.Fujioka	Refer to Revision Record on page 2.	No.			
06	Mar.10, 08	K.Okada	T.Anzai	I.Fujioka	Refer to Revision Record on page 2.				
Rev.	DATE	DESIGN	CHECK	APPR.	DESCRIPTION	PFU LIMITED		Page	225 / 257
Design	July 27, 2007	K.Okada	CHECK	K.Okada		APPR.	T.Anzai		

- (4) - Disconnect the cable (circle below) on the IMP CT.
- Remove four screws C (circles below), and then remove the IMP CT from the PCA cover.

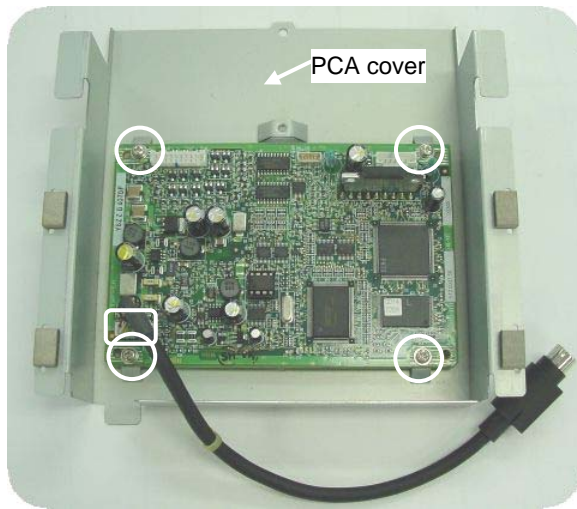

<Installation>

Follow the removing procedure in reverse.

Note: Place the cable tie of the IMP CT inside of the Imprinter bottom.

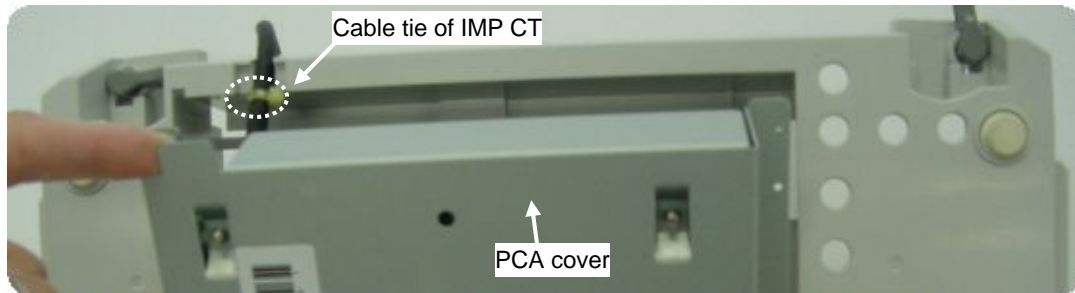

						TITLE	fi-6140/fi-6240/fi-6130/fi-6230/fi-614PR Maintenance Manual		
08	July 27, 09	K.Okada	A.Miyoshi	I.Fujioka	Refer to Revision Record on page 2.	DRAW No.	P1PA03540-B0XX/6	CUST.	
07	Nov.12, 08	K.Okada	T.Anzai	I.Fujioka	Refer to Revision Record on page 2.				
06	Mar.10, 08	K.Okada	T.Anzai	I.Fujioka	Refer to Revision Record on page 2.				
Rev.	DATE	DESIGN	CHECK	APPR.	DESCRIPTION	PFU LIMITED		Page	226 / 257
Design	July 27, 2007	K.Okada	CHECK	K.Okada					

8-6-10 SENSOR

NOTICE

- Refer to Section 8-4-1 for the part number of the maintenance part.
- Refer to Appendix for the specification of the screws.

<Removal>

1. Remove the Imprinter.

(1) Referring to Section 8-6-4 “Removing Imprinter,” remove the Imprinter.

2. Remove the Print section cover.

(2) Referring to steps (2) ~ (4) of Section 8-6-6 “IM PINCH ASSY3,” remove the Print section cover.

3. Remove the PCA cover.

(3) Referring to steps (2) ~ (3) of Section 8-6-9 “IMP CT,” remove the PCA cover.

4. Remove the SENSOR.

(4) Remove three screws A (circles below) on the inner cover.

Note: There are two hooks (square below) at the both edges. Lifting up the inner cover a little to pull towards you. 05

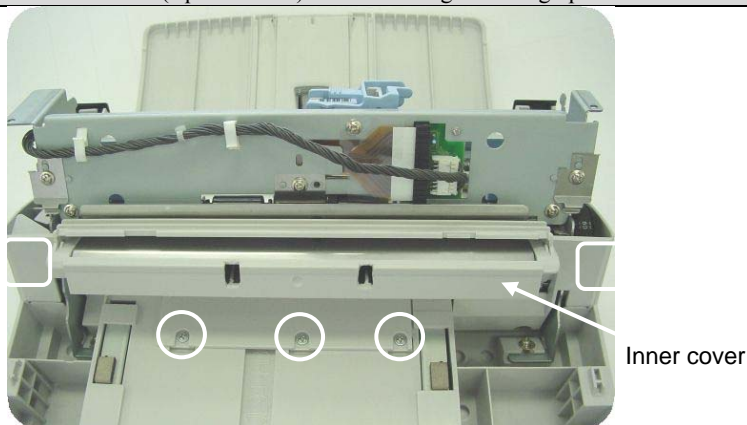

(5) Draw out the internal cover to the rear of the Imprinter to remove.

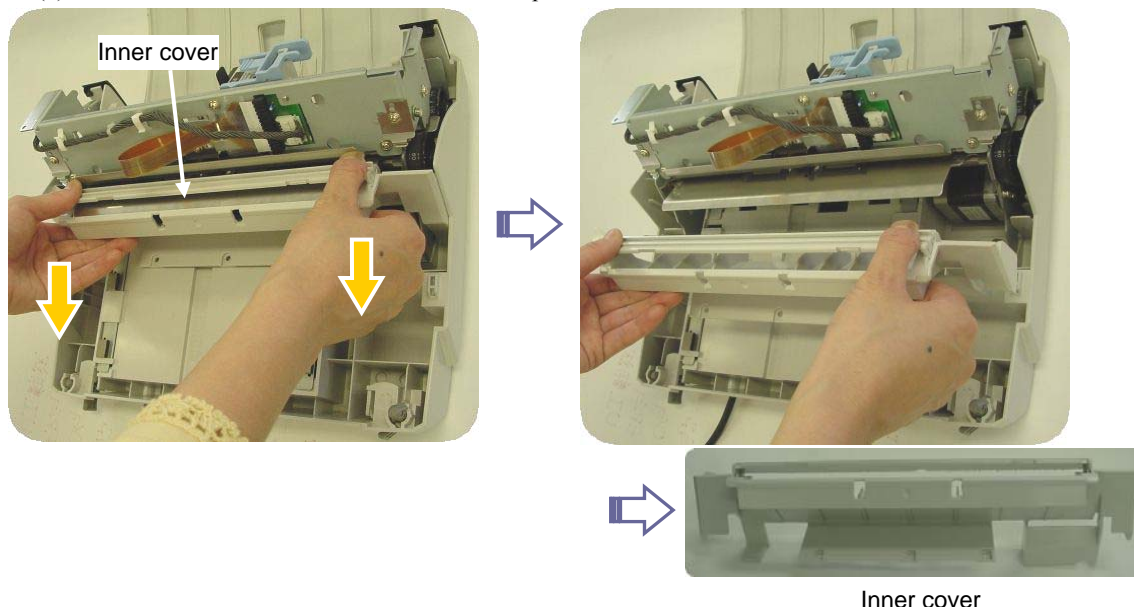

						TITLE	fi-6140/fi-6240/fi-6130/fi-6230/fi-614PR Maintenance Manual		
08	July 27, 09	K.Okada	A.Miyoshi	I.Fujioka	Refer to Revision Record on page 2.	DRAW No.	P1PA03540-B0XX/6		CUST.
07	Nov.12, 08	K.Okada	T.Anzai	I.Fujioka	Refer to Revision Record on page 2.				
06	Mar.10, 08	K.Okada	T.Anzai	I.Fujioka	Refer to Revision Record on page 2.				
Rev.	DATE	DESIGN	CHECK	APPR.	DESCRIPTION	PFU LIMITED		Page	227 / 257
Design	July 27, 2007	K.Okada	CHECK	K.Okada		APPR.	T.Anzai		

(6) Remove the SENSOR connector (square below), and two screws C and washers at the mechanical section.

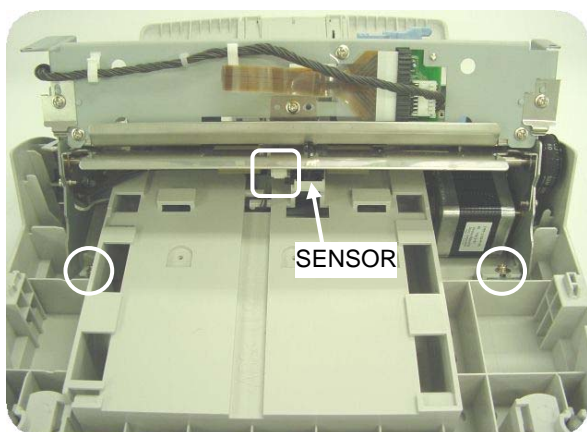

(7) Remove the mechanical section in the direction of the arrow to remove.

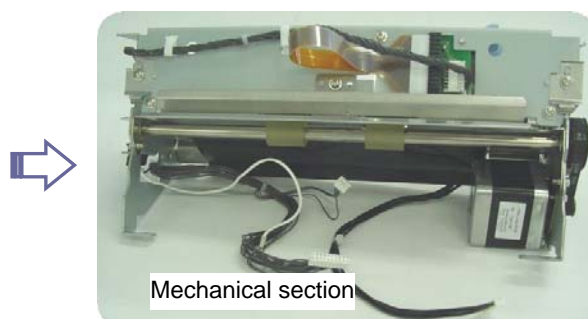
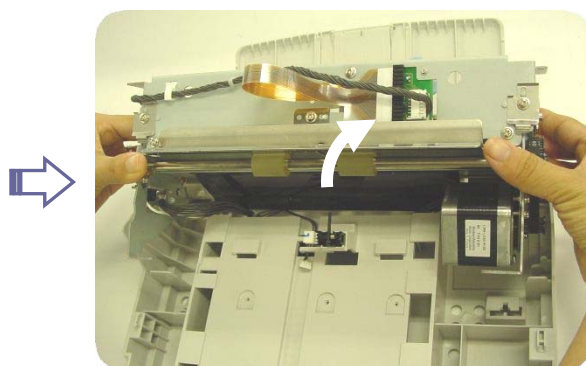
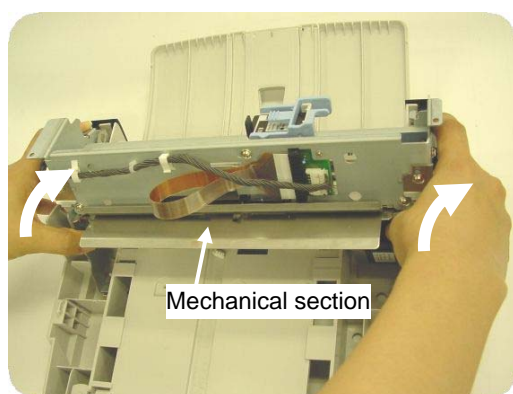

						TITLE	fi-6140/fi-6240/fi-6130/fi-6230/fi-614PR Maintenance Manual		
08	July 27, 09	K.Okada	A.Miyoshi	I.Fujioka	Refer to Revision Record on page 2.	DRAW	P1PA03540-B0XX/6	CUST.	
07	Nov.12, 08	K.Okada	T.Anzai	I.Fujioka	Refer to Revision Record on page 2.	No.			
06	Mar.10, 08	K.Okada	T.Anzai	I.Fujioka	Refer to Revision Record on page 2.				
Rev.	DATE	DESIGN	CHECK	APPR.	DESCRIPTION	PFU LIMITED		Page	228 / 257
Design	July 27, 2007	K.Okada	CHECK	K.Okada		APPR.	T.Anzai		

(8) Unlatch the claw (square below) that holds the SENSOR to remove the SENSOR.

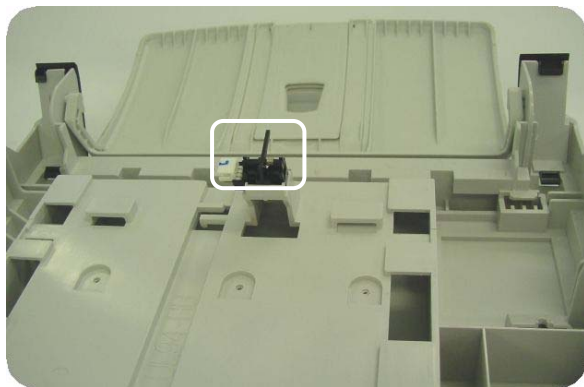

<Installation>

Follow the removing procedure in reverse.

Note: Make sure that the SENOR claw is securely latched.

Note: Route the SENOR lever above the roller shaft, and insert it into the hole on the mechanical section.
Connect the SENSOR cable to the position marked with a square in the photo below.

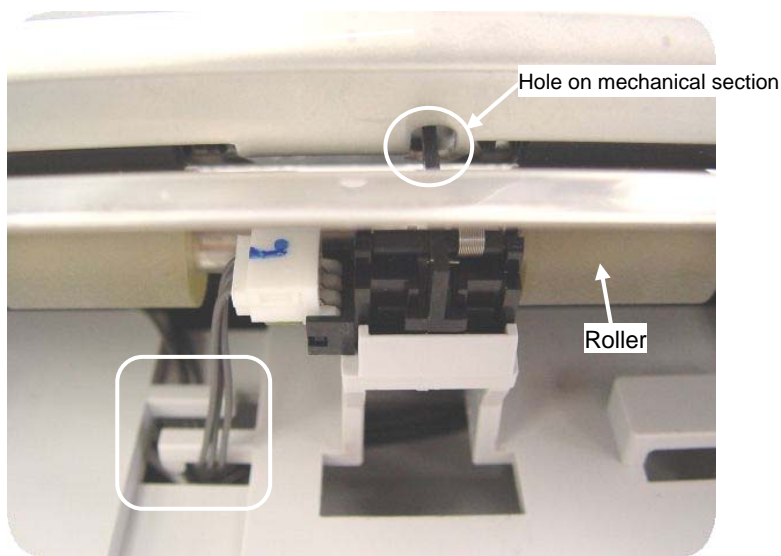

						TITLE	fi-6140/fi-6240/fi-6130/fi-6230/fi-614PR Maintenance Manual		
08	July 27, 09	K.Okada	A.Miyoshi	I.Fujioka	Refer to Revision Record on page 2.	DRAW No.	P1PA03540-B0XX/6	CUST.	
07	Nov.12, 08	K.Okada	T.Anzai	I.Fujioka	Refer to Revision Record on page 2.				
06	Mar.10, 08	K.Okada	T.Anzai	I.Fujioka	Refer to Revision Record on page 2.				
Rev.	DATE	DESIGN	CHECK	APPR.	DESCRIPTION	PFU LIMITED		Page	229 / 257
Design	July 27, 2007	K.Okada	CHECK	K.Okada					

8-6-11 SWITCH (Cover open detection)

NOTICE

- Refer to Section 8-4-12 for the part number of the maintenance part.

<Removal>

1. Remove the Imprinter.

(1) Referring to Section 8-6-4 "Removing Imprinter," remove the Imprinter.

2. Remove the Print section cover.

(2) Referring to steps (2) ~ (4) of Section 8-6-6 "IM PINCH ASSY3," remove the Print section cover.

3. Remove the PCA cover.

(3) Referring to steps (2) ~ (3) of Section 8-6-9 "IMP CT," remove the PCA cover.

4. Remove the Inner cover and Mechanical section.

(4) Referring to steps (4) ~ (7) of Section 8-6-10 "SENSOR," remove the inner cover and mechanical section.

5. Remove the SWITCH.

(5) - Open the mechanical section cover **1**, and then disconnect the SWITCH cable (circle below) **2**.

- Unlatch the SWITCH claws **3**, and then move the SWITCH to remove **4**.

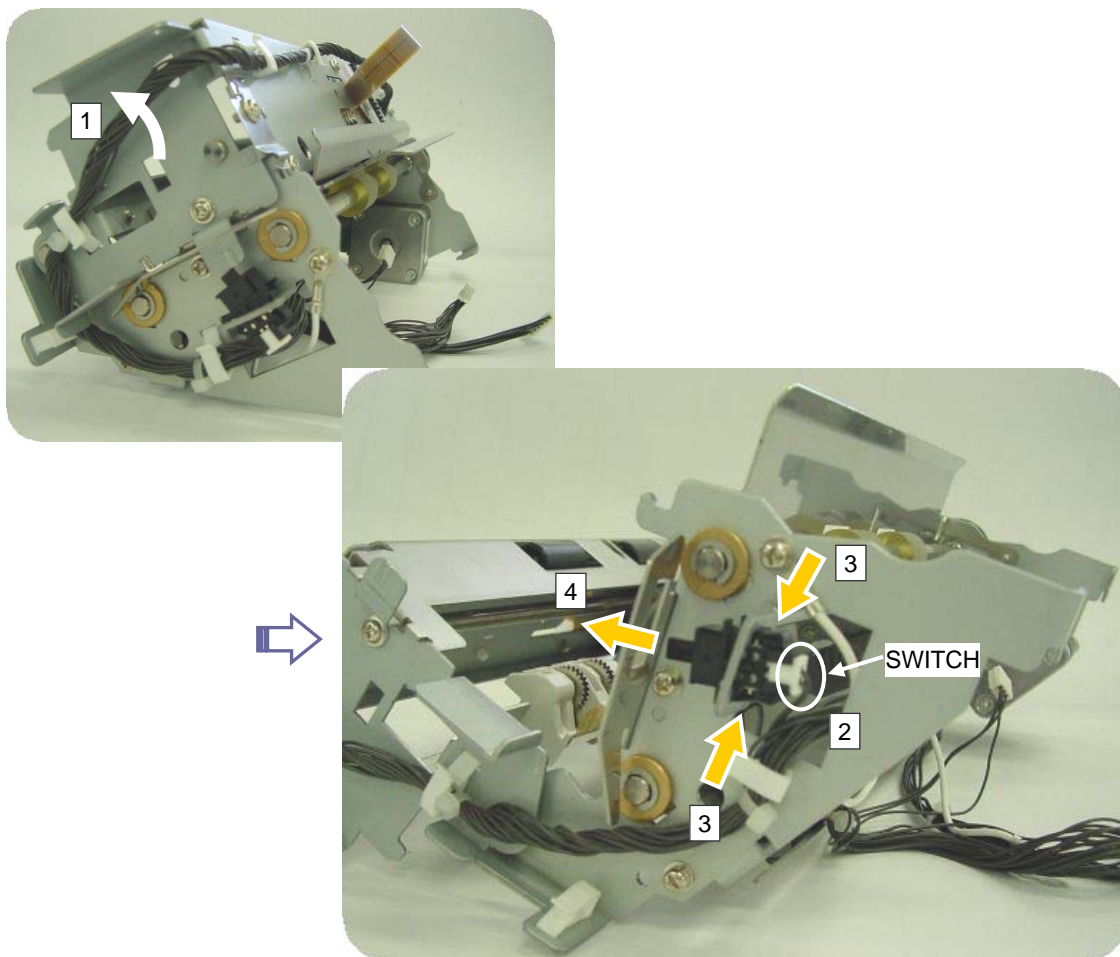

						TITLE	fi-6140/fi-6240/fi-6130/fi-6230/fi-614PR Maintenance Manual		
08	July 27, 09	K.Okada	A.Miyoshi	I.Fujioka	Refer to Revision Record on page 2.	DRAW	P1PA03540-B0XX/6	CUST.	
07	Nov.12, 08	K.Okada	T.Anzai	I.Fujioka	Refer to Revision Record on page 2.	No.			
06	Mar.10, 08	K.Okada	T.Anzai	I.Fujioka	Refer to Revision Record on page 2.				
Rev.	DATE	DESIGN	CHECK	APPR.	DESCRIPTION	PFU LIMITED		Page	230 / 257
Design	July 27, 2007	K.Okada	CHECK	K.Okada		APPR.	T.Anzai		

<Installation>

Follow the removing procedure in reverse.

Note: Place the SWITCH connector outside of the Imprinter.

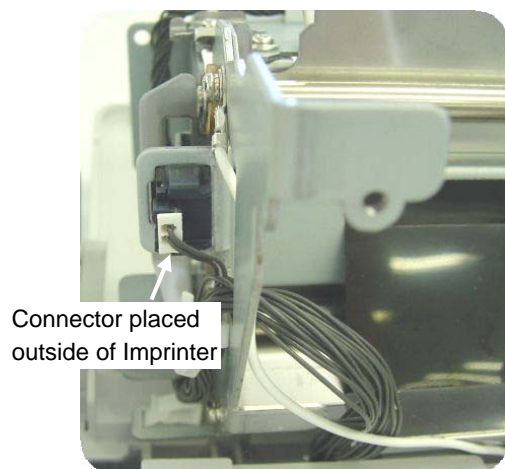

						TITLE	fi-6140/fi-6240/fi-6130/fi-6230/fi-614PR Maintenance Manual		
08	July 27, 09	K.Okada	A.Miyoshi	I.Fujioka	Refer to Revision Record on page 2.	DRAW No.	P1PA03540-B0XX/6	CUST.	
07	Nov.12, 08	K.Okada	T.Anzai	I.Fujioka	Refer to Revision Record on page 2.				
06	Mar.10, 08	K.Okada	T.Anzai	I.Fujioka	Refer to Revision Record on page 2.				
Rev.	DATE	DESIGN	CHECK	APPR.	DESCRIPTION	PFU LIMITED		Page	231 / 257
Design	July 27, 2007	K.Okada	CHECK	K.Okada					

8-6-12 LF MOTOR

NOTICE

- Refer to Section 8-4-6 for the part number of the maintenance part.
- Refer to Appendix for the specification of the screws.

<Removal>

1. Remove the Imprinter.

(1) Referring to Section 8-6-4 "Removing Imprinter," remove the Imprinter.

2. Remove the Print section cover.

(2) Referring to steps (2) ~ (4) of Section 8-6-6 "IM PINCH ASSY3," remove the Print section cover.

3. Remove the PCA cover.

(3) Referring to steps (2) ~ (3) of Section 8-6-9 "IMP CT," remove the PCA cover.

4. Remove the Inner cover and Mechanical section.

(4) Referring to steps (4) ~ (7) of Section 8-6-10 "SENSOR," remove the inner cover and mechanical section.

5. Remove the LF MOTOR.

(5) Remove two LF MOTOR screws C (circles below), and then remove the LF MOTOR.

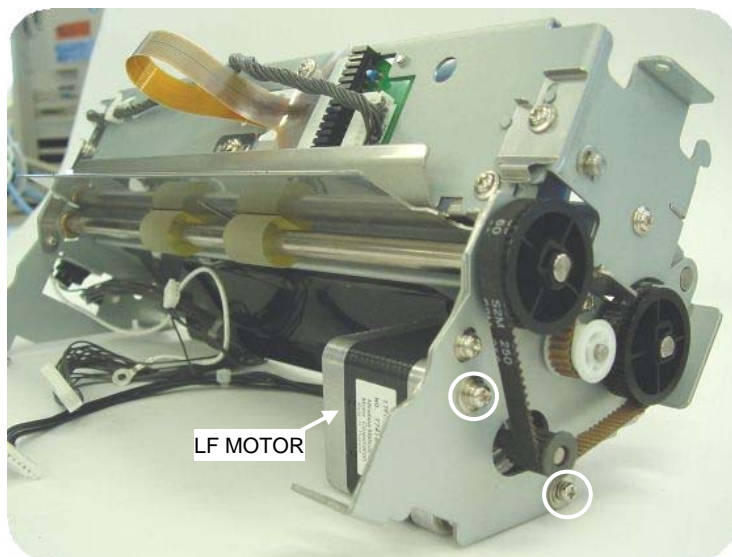

						TITLE	fi-6140/fi-6240/fi-6130/fi-6230/fi-614PR Maintenance Manual		
08	July 27, 09	K.Okada	A.Miyoshi	I.Fujioka	Refer to Revision Record on page 2.	DRAW No.	P1PA03540-B0XX/6	CUST.	
07	Nov.12, 08	K.Okada	T.Anzai	I.Fujioka	Refer to Revision Record on page 2.				
06	Mar.10, 08	K.Okada	T.Anzai	I.Fujioka	Refer to Revision Record on page 2.				
Rev.	DATE	DESIGN	CHECK	APPR.	DESCRIPTION	PFU LIMITED		Page	232 / 257
Design	July 27, 2007	K.Okada	CHECK	K.Okada		APPR.	T.Anzai		

<Installation>

Follow the removing procedure in reverse.

Note: Adjust LF MOTOR belt tension.
Set the FEED PULLEY in the direction as shown below. (Error: $\pm 25^\circ$) 05

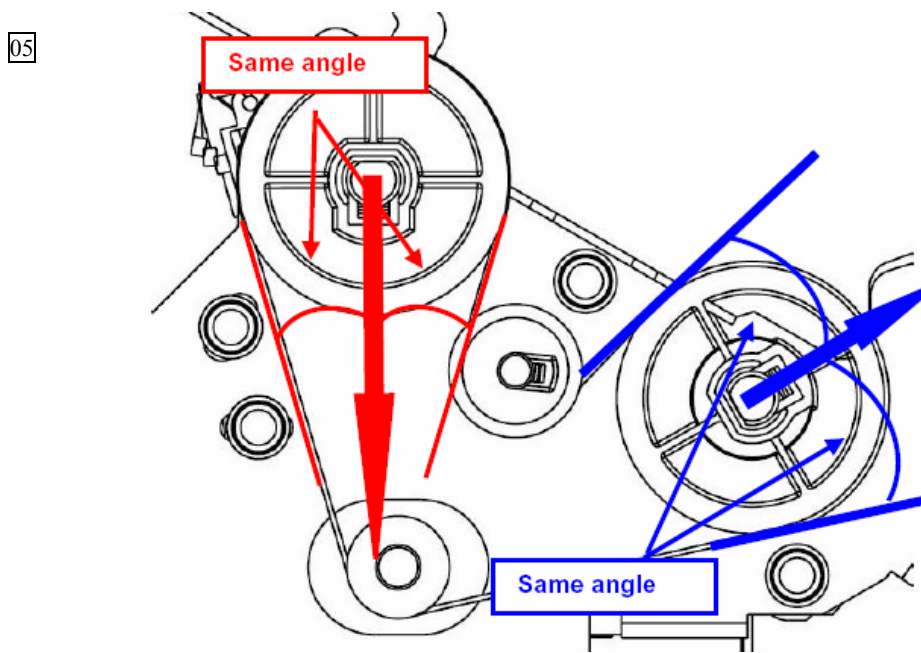

- 05
(1) Place the unit vertically as shown below.

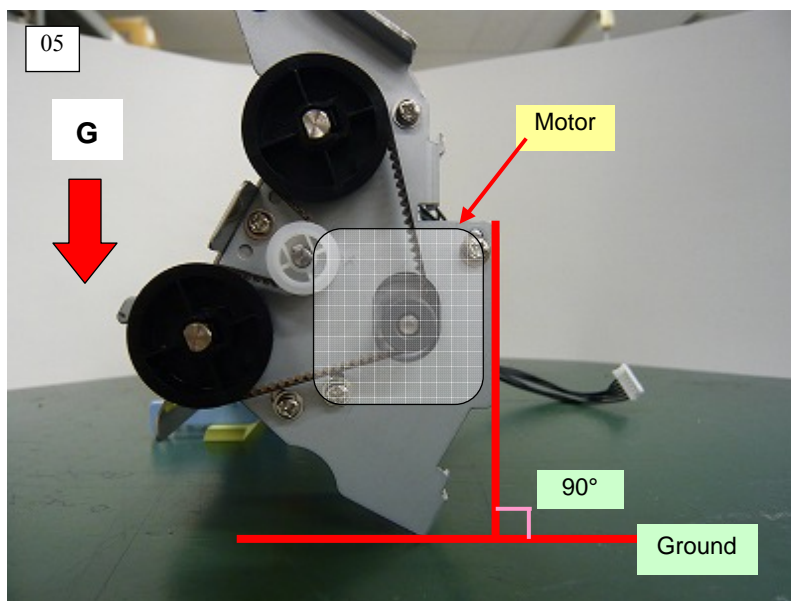

						TITLE	fi-6140/fi-6240/fi-6130/fi-6230/fi-614PR Maintenance Manual		
08	July 27, 09	K.Okada	A.Miyoshi	I.Fujioka	Refer to Revision Record on page 2.	DRAW No.	P1PA03540-B0XX/6		CUST.
07	Nov.12, 08	K.Okada	T.Anzai	I.Fujioka	Refer to Revision Record on page 2.				
06	Mar.10, 08	K.Okada	T.Anzai	I.Fujioka	Refer to Revision Record on page 2.				
Rev.	DATE	DESIGN	CHECK	APPR.	DESCRIPTION	PFU LIMITED		Page	233 / 257
Design	July 27, 2007	K.Okada	CHECK	K.Okada		APPR.	T.Anzai		

05

(2) Pushing up the motor surface vertically with $f=150\pm 50gf$, tighten two screws (circles below).

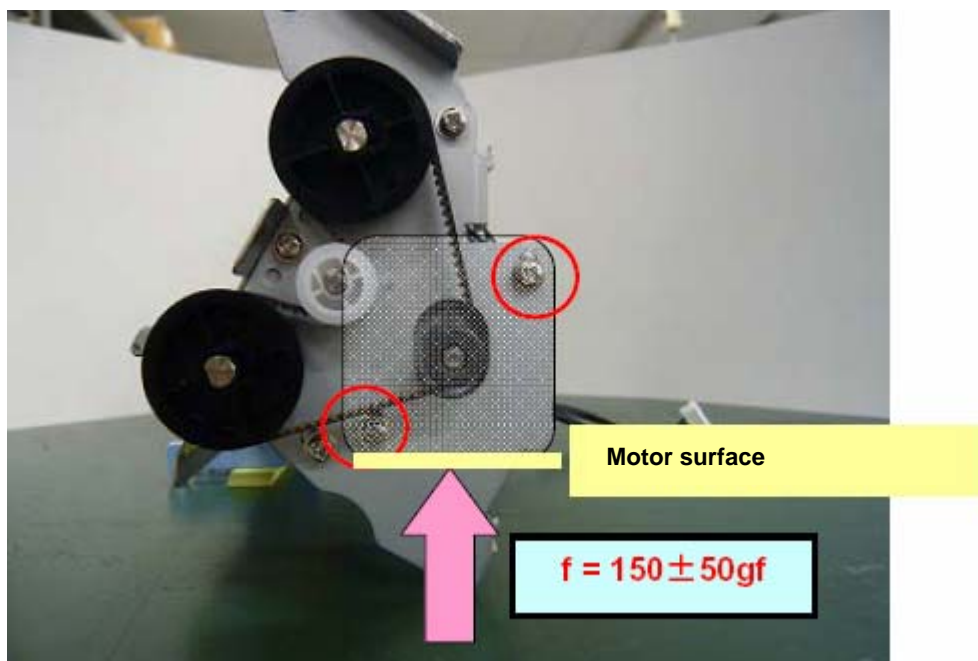

(3) Pushing the reference point (22mm) with a spring gage to bend 3 mm, check the belt tension ($f=300\pm 100gf$).

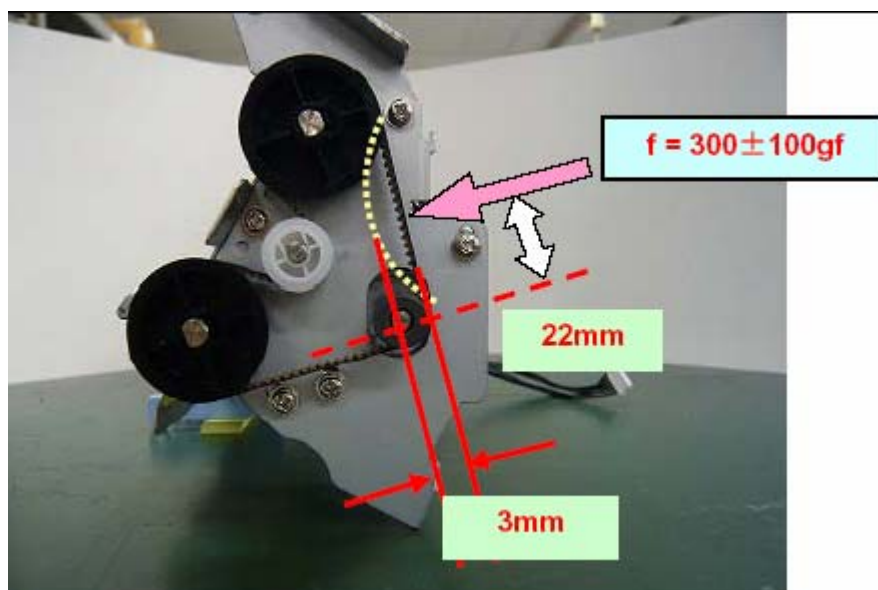

						TITLE	fi-6140/fi-6240/fi-6130/fi-6230/fi-614PR Maintenance Manual		
08	July 27, 09	K.Okada	A.Miyoshi	I.Fujioka	Refer to Revision Record on page 2.	DRAW No.	P1PA03540-B0XX/6		CUST.
07	Nov.12, 08	K.Okada	T.Anzai	I.Fujioka	Refer to Revision Record on page 2.				
06	Mar.10, 08	K.Okada	T.Anzai	I.Fujioka	Refer to Revision Record on page 2.				
Rev.	DATE	DESIGN	CHECK	APPR.	DESCRIPTION	PFU LIMITED		Page	234 / 257
Design	July 27, 2007	K.Okada	CHECK	K.Okada		APPR.	T.Anzai		

8-6-13 PR HARNESS

NOTICE

- Refer to Section 8-4-4 for the part number of the maintenance part.

<Removal>

1. Remove the Imprinter.

(1) Referring to Section 8-6-4 “Removing Imprinter,” remove the Imprinter.

2. Remove the Print section cover.

(2) Referring to steps (2) ~ (4) of Section 8-6-6 “IM PINCH ASSY3,” remove the Print section cover.

3. Remove the PCA cover.

(3) Referring to steps (2) ~ (3) of Section 8-6-9 “IMP CT,” remove the PCA cover.

4. Remove the Inner cover and Mechanical section.

(4) Referring to steps (4) ~ (7) of Section 8-6-10 “SENSOR,” remove the inner cover and mechanical section.

5. Remove the PR HARNESS.

(5) - Unhook five cable clamps (circles below) for the PR HARNESS.

- Disconnect the connector (square below) of the IMP JNT, and then remove the PR HARNESS.

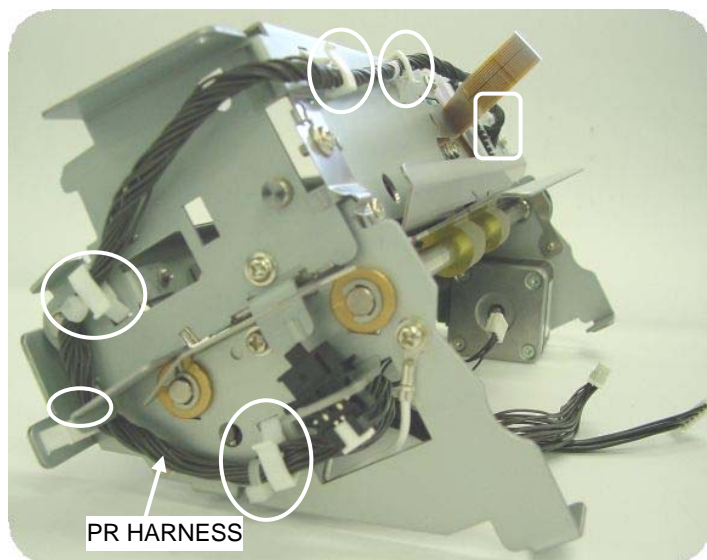

<Installation>

Follow the removing procedure in reverse.

						TITLE	fi-6140/fi-6240/fi-6130/fi-6230/fi-614PR Maintenance Manual		
08	July 27, 09	K.Okada	A.Miyoshi	I.Fujioka	Refer to Revision Record on page 2.	DRAW No.	P1PA03540-B0XX/6	CUST.	
07	Nov.12, 08	K.Okada	T.Anzai	I.Fujioka	Refer to Revision Record on page 2.				
06	Mar.10, 08	K.Okada	T.Anzai	I.Fujioka	Refer to Revision Record on page 2.				
Rev.	DATE	DESIGN	CHECK	APPR.	DESCRIPTION	PFU LIMITED		Page	235 / 257
Design	July 27, 2007	K.Okada	CHECK	K.Okada		APPR.	T.Anzai		

8-6-14 IM FELT

 NOTICE

- Refer to Section 8-4-5 for the part number of the maintenance part.
- Refer to Appendix for the specification of the screws.

<Removal>

1. Remove the Imprinter.

(1) Referring to Section 8-6-4 "Removing Imprinter," remove the Imprinter.

2. Remove the Print section cover.

(2) Referring to steps (2) ~ (4) of Section 8-6-6 "IM PINCH ASSY3," remove the Print section cover.

3. Remove the PCA cover.

(3) Referring to steps (2) ~ (3) of Section 8-6-9 "IMP CT," remove the PCA cover.

4. Remove the Inner cover and Mechanical section.

(4) Referring to steps (4) ~ (7) of Section 8-6-10 "SENSOR," remove the inner cover and mechanical section.

5. Remove the IM FELT.

(5) Remove four screws C (circle below) of the Guide P ASSY.

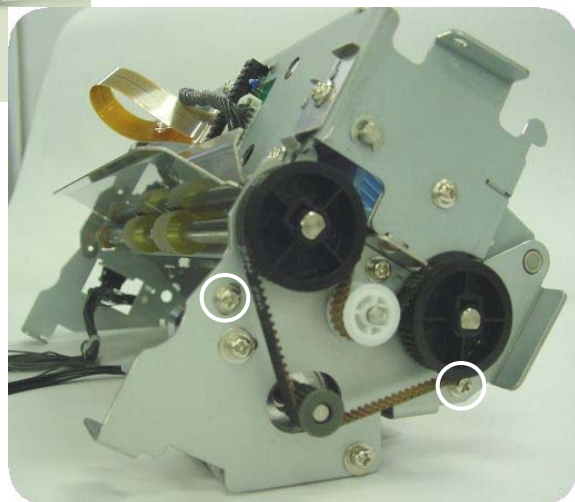
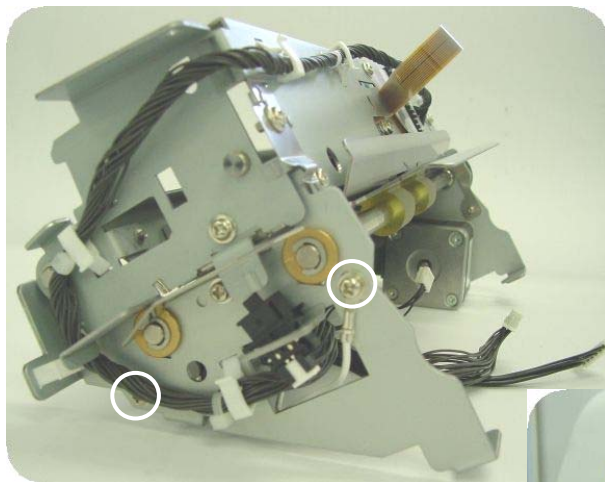

						TITLE	fi-6140/fi-6240/fi-6130/fi-6230/fi-614PR Maintenance Manual		
08	July 27, 09	K.Okada	A.Miyoshi	I.Fujioka	Refer to Revision Record on page 2.	DRAW	P1PA03540-B0XX/6	CUST.	
07	Nov.12, 08	K.Okada	T.Anzai	I.Fujioka	Refer to Revision Record on page 2.	No.			
06	Mar.10, 08	K.Okada	T.Anzai	I.Fujioka	Refer to Revision Record on page 2.				
Rev.	DATE	DESIGN	CHECK	APPR.	DESCRIPTION	PFU LIMITED		Page	236 / 257
Design	July 27, 2007	K.Okada	CHECK	K.Okada		APPR.	T.Anzai		

- (6) - Open the mechanical section cover. 1
- Remove the Guide P ASSY 2, and then remove the IM FELT.

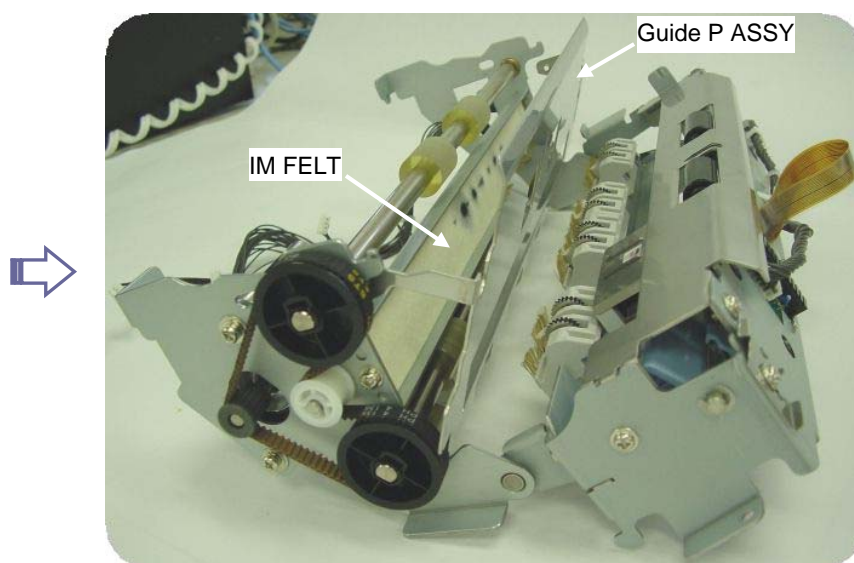
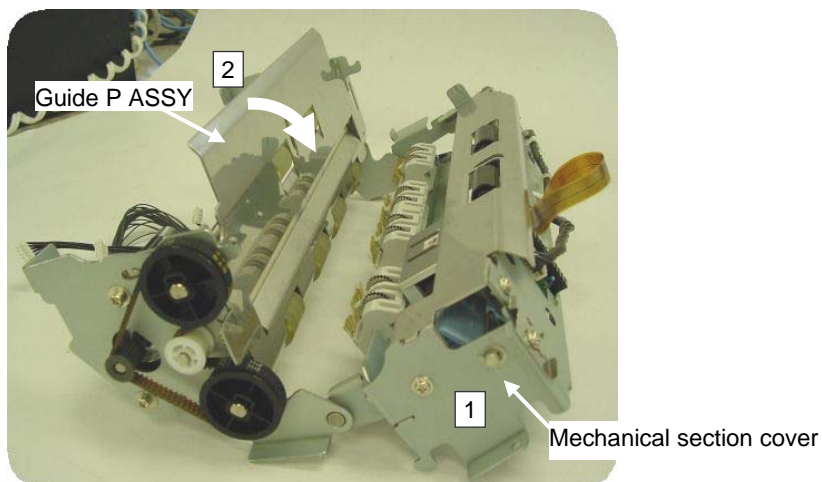

<Installation>

Follow the removing procedure in reverse.

						TITLE	fi-6140/fi-6240/fi-6130/fi-6230/fi-614PR Maintenance Manual		
08	July 27, 09	K.Okada	A.Miyoshi	I.Fujioka	Refer to Revision Record on page 2.	DRAW	P1PA03540-B0XX/6	CUST.	
07	Nov.12, 08	K.Okada	T.Anzai	I.Fujioka	Refer to Revision Record on page 2.	No.			
06	Mar.10, 08	K.Okada	T.Anzai	I.Fujioka	Refer to Revision Record on page 2.				
Rev.	DATE	DESIGN	CHECK	APPR.	DESCRIPTION	PFU LIMITED		Page	237 / 257
Design	July 27, 2007	K.Okada	CHECK	K.Okada		APPR.	T.Anzai		

8-6-15 IM LOCK LEVER

NOTICE

- Refer to Section 8-4-11 for the part number of the maintenance part.

<Removal>

1. Remove the Imprinter.

(1) Referring to Section 8-6-4 “Removing Imprinter,” remove the Imprinter.

2. Remove the IM LOCK LEVER.

(2) Unlatch the claws of the IM LOCK LEVER (circles below), remove the IM LOCK LEVER.

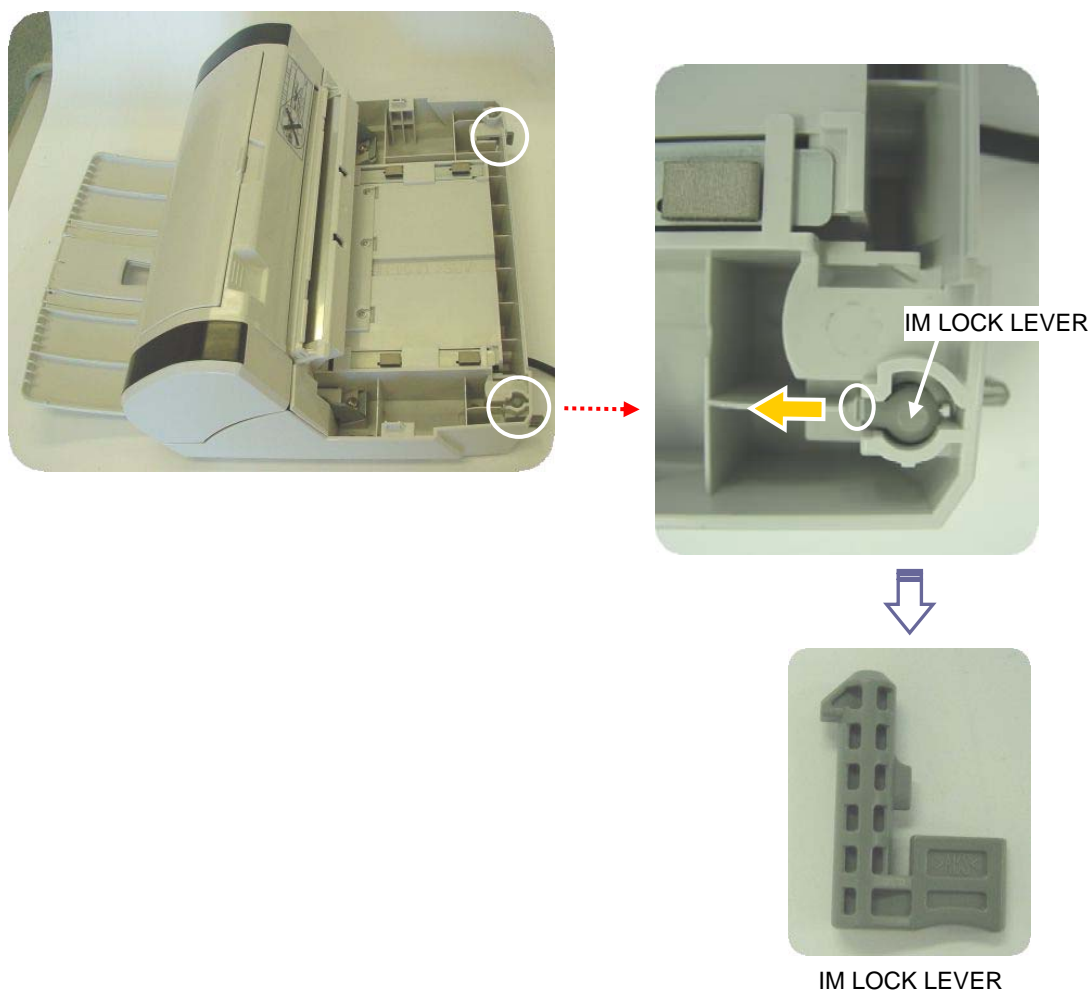

<Installation>

Follow the removing procedure in reverse.

						TITLE	fi-6140/fi-6240/fi-6130/fi-6230/fi-614PR Maintenance Manual		
08	July 27, 09	K.Okada	A.Miyoshi	I.Fujioka	Refer to Revision Record on page 2.	DRAW	P1PA03540-B0XX/6	CUST.	
07	Nov.12, 08	K.Okada	T.Anzai	I.Fujioka	Refer to Revision Record on page 2.	No.			
06	Mar.10, 08	K.Okada	T.Anzai	I.Fujioka	Refer to Revision Record on page 2.				
Rev.	DATE	DESIGN	CHECK	APPR.	DESCRIPTION	PFU LIMITED		Page	238 / 257
Design	July 27, 2007	K.Okada	CHECK	K.Okada		APPR.	T.Anzai		

8-6-16 GUIDE SHEET

 NOTICE

- Refer to Section 8-4-13 for the part number of the maintenance part.

<Removal>

1. Remove the Imprinter.

(1) Referring to Section 8-6-4 "Removing Imprinter," remove the Imprinter.

2. Remove the Print section cover.

(2) Referring to steps (2) ~ (4) of Section 8-6-6 "IM PINCH ASSY3," remove the Print section cover.

3. Remove the PCA cover.

(3) Referring to steps (2) ~ (3) of Section 8-6-9 "IMP CT," remove the PCA cover.

4. Remove the Inner cover and Mechanical section.

(4) Referring to steps (4) ~ (7) of Section 8-6-10 "SENSOR," remove the inner cover and mechanical section.

5. Remove the GUIDE SHEET.

(5) Remove the GUIDE SHEET.

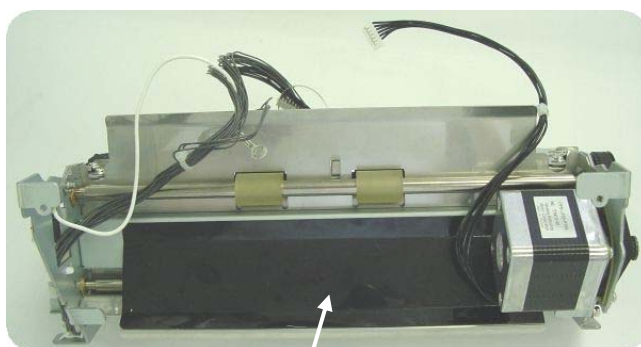

GUIDE SHEET

<Installation>

Follow the removing procedure in reverse.

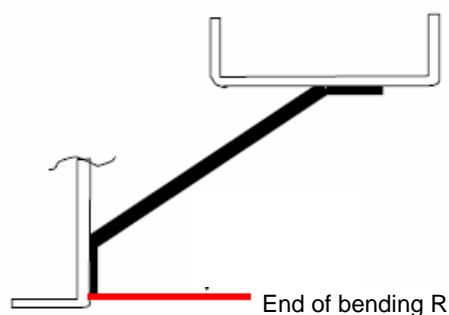
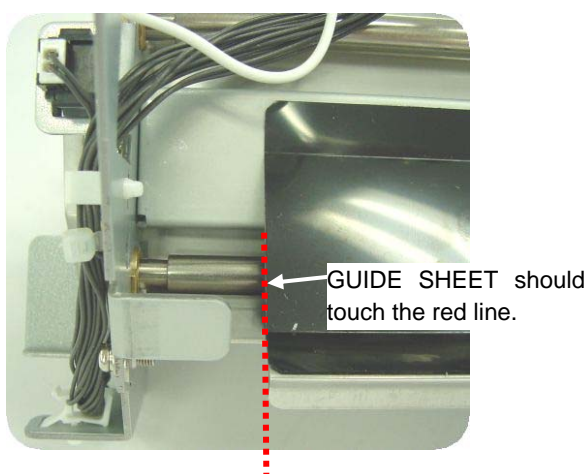

Rev.	DATE	DESIGN	CHECK	APPR.	DESCRIPTION	PFU LIMITED		
08	July 27, 09	K.Okada	A.Miyoshi	I.Fujioka	Refer to Revision Record on page 2.	TITLE	fi-6140/fi-6240/fi-6130/fi-6230/fi-614PR Maintenance Manual	
07	Nov.12, 08	K.Okada	T.Anzai	I.Fujioka	Refer to Revision Record on page 2.	DRAW No.	P1PA03540-B0XX/6	CUST.
06	Mar.10, 08	K.Okada	T.Anzai	I.Fujioka	Refer to Revision Record on page 2.			
Design	July 27, 2007	K.Okada	CHECK	K.Okada	APPR.	T.Anzai	Page	239 / 257

8-7 Adjustment/Settings

See Chapter 6 “Adjustment/Settings.”

						TITLE	fi-6140/fi-6240/fi-6130/fi-6230/fi-614PR Maintenance Manual		
08	July 27, 09	K.Okada	A.Miyoshi	I.Fujioka	Refer to Revision Record on page 2.	DRAW No.	P1PA03540-B0XX/6	CUST.	
07	Nov.12, 08	K.Okada	T.Anzai	I.Fujioka	Refer to Revision Record on page 2.				
06	Mar.10, 08	K.Okada	T.Anzai	I.Fujioka	Refer to Revision Record on page 2.				
Rev.	DATE	DESIGN	CHECK	APPR.	DESCRIPTION	PFU LIMITED		Page	240 / 257
Design	July 27, 2007	K.Okada	CHECK	K.Okada		APPR.	T.Anzai		

8-8 Basic Operation and Daily Care of the Imprinter

8-8-1 Setting The Print Position

To position the print cartridge for printing:

1. Open the Print Cartridge Cover.
2. Hold the Print Cartridge Holder as below, and slide it to the left and right within the document width to set it at a suitable print starting position.

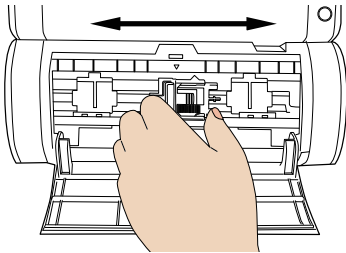

-
- The triangle-shaped protrusion “▲” on the locking lever of the Print Cartridge Holder indicates the current print position on the page.
 - In the upper back of the Print Cartridge Holder are document size markings; Use them to adjust for paper sizes and printing positions.
 - Put the actual document in the ADF and confirm that the print cartridge is positioned within the document width.
-

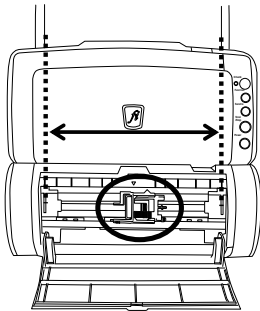

						TITLE	fi-6140/fi-6240/fi-6130/fi-6230/fi-614PR Maintenance Manual		
08	July 27, 09	K.Okada	A.Miyoshi	I.Fujioka	Refer to Revision Record on page 2.	DRAW No.	P1PA03540-B0XX/6	CUST.	
07	Nov.12, 08	K.Okada	T.Anzai	I.Fujioka	Refer to Revision Record on page 2.				
06	Mar.10, 08	K.Okada	T.Anzai	I.Fujioka	Refer to Revision Record on page 2.				
Rev.	DATE	DESIGN	CHECK	APPR.	DESCRIPTION	PFU LIMITED		Page	241 / 257
Design	July 27, 2007	K.Okada	CHECK	K.Okada		APPR.	T.Anzai		

8-8-2 How to Use the Paper Guides

NOTICE

The Paper Guides are maintenance parts. Refer to Section 8-4-14 for the part number of the replacement part.

Use the Paper Guides to prevent against paper jams due to curling of the edges, as shown on the right.

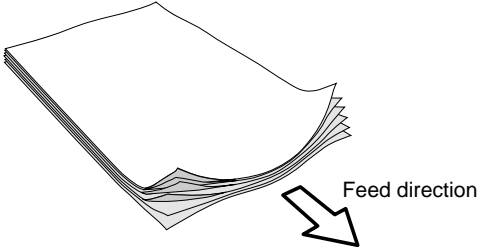

Place the Paper Guides at the ends where the paper edges will pass through.

1. Insert the document in the scanner.
2. Open the Print Cartridge Cover.
3. Slide the Paper Guides to the left and right edges of the paper.

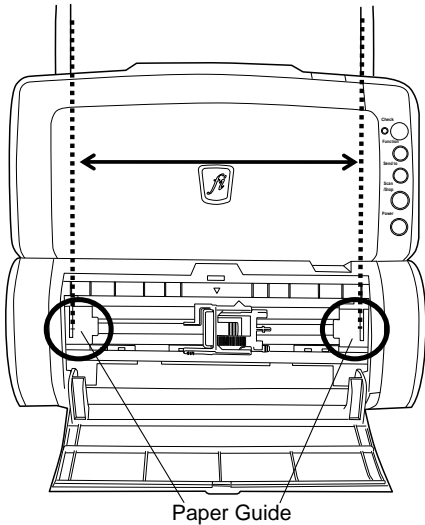

When you wish to print on a section near the edge of wide paper, remove the Paper Guide in order to open space for the print cartridge, and attach the removed guide in the center.

For Right-Edge printing

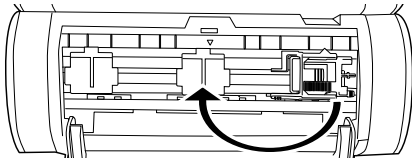

For Left-Edge printing

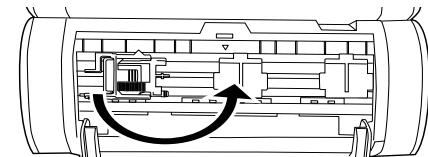

Be careful not to let the Paper Guide touch or catch onto the print circuit film.

						TITLE	fi-6140/fi-6240/fi-6130/fi-6230/fi-614PR Maintenance Manual		
08	July 27, 09	K.Okada	A.Miyoshi	I.Fujioka	Refer to Revision Record on page 2.	DRAW No.	P1PA03540-B0XX/6	CUST.	
07	Nov.12, 08	K.Okada	T.Anzai	I.Fujioka	Refer to Revision Record on page 2.				
06	Mar.10, 08	K.Okada	T.Anzai	I.Fujioka	Refer to Revision Record on page 2.				
Rev.	DATE	DESIGN	CHECK	APPR.	DESCRIPTION	PFU LIMITED		Page	242 / 257
Design	July 27, 2007	K.Okada	CHECK	K.Okada		APPR.	T.Anzai		

<To Remove the Paper Guides>

Pressing and holding together with your fingers, as below, lift up and pull away the guide.

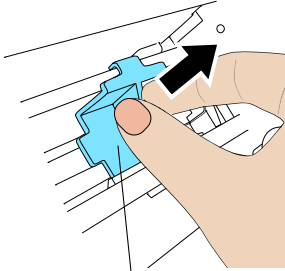

Paper Guide

<To Attach the Paper Guides>

1. Put the Paper Guides in place as in the picture on the left below.

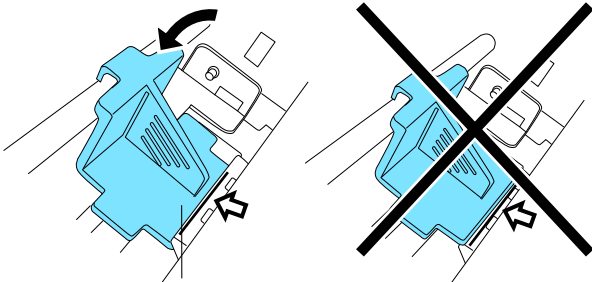

Paper Guide

2. Push in the top portion of the guide to fit tightly.

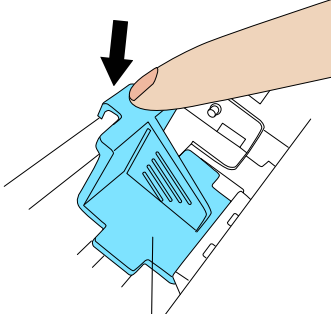

Paper Guide

						TITLE	fi-6140/fi-6240/fi-6130/fi-6230/fi-614PR Maintenance Manual		
08	July 27, 09	K.Okada	A.Miyoshi	I.Fujioka	Refer to Revision Record on page 2.	DRAW No.	P1PA03540-B0XX/6	CUST.	
07	Nov.12, 08	K.Okada	T.Anzai	I.Fujioka	Refer to Revision Record on page 2.				
06	Mar.10, 08	K.Okada	T.Anzai	I.Fujioka	Refer to Revision Record on page 2.				
Rev.	DATE	DESIGN	CHECK	APPR.	DESCRIPTION	PFU LIMITED		Page	243 / 257
Design	July 27, 2007	K.Okada	CHECK	K.Okada		APPR.	T.Anzai		

8-8-3 Print Setup

You can configure settings for the Imprinter by using the scanner driver’s setup dialog box.

FUJITSU TWAIN driver (example)

Click **[Option]** button.

In the [Option] dialog box, choose the [Imprinter (Endorser)] tab, and configure the settings for the Imprinter.

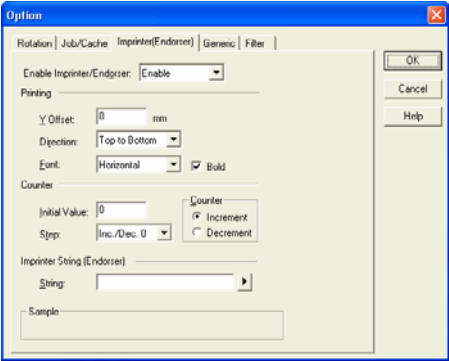

The following items can be set:

- **Imprinter (endorser) valid (F)**
 Select “Invalid” if you are not going to print with the Imprinter.
 Select “Valid” if you are going to print with the Imprinter

- **Offset (Y)**
 Specify the print position (L) shown in the photo on the right in unit of mm.

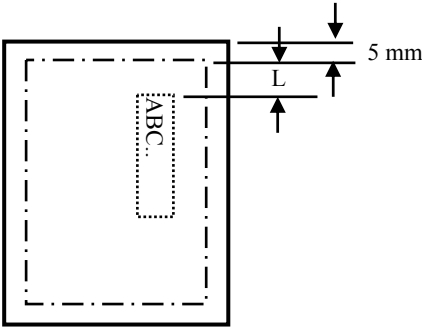

						TITLE	fi-6140/fi-6240/fi-6130/fi-6230/fi-614PR Maintenance Manual		
08	July 27, 09	K.Okada	A.Miyoshi	I.Fujioka	Refer to Revision Record on page 2.	DRAW No.	P1PA03540-B0XX/6	CUST.	
07	Nov.12, 08	K.Okada	T.Anzai	I.Fujioka	Refer to Revision Record on page 2.				
06	Mar.10, 08	K.Okada	T.Anzai	I.Fujioka	Refer to Revision Record on page 2.				
Rev.	DATE	DESIGN	CHECK	APPR.	DESCRIPTION	PFU LIMITED		Page	244 / 257
Design	July 27, 2007	K.Okada	CHECK	K.Okada		APPR.	T.Anzai		

- Output direction (R) and Font (F)

Specify the print direction in the following combination.

		Output direction (R)	
		“Down”	“Up”
Font (F)	“Vertical”	<p>(Back side)</p>	<p>(Back side)</p>
	“Horizontal”	<p>(Back side)</p>	<p>(Back side)</p>

- Bold

Input the check mark on this item if you want to make the characters bold.

- Initial value (counter output)

Specify the initial value of the counter output.

- Step (counter output)

Specify the increase and decrease range of the counter.

- Counter revision (counter output)

Specify whether the counter value is added or subtracted.

						TITLE	fi-6140/fi-6240/fi-6130/fi-6230/fi-614PR Maintenance Manual			
08	July 27, 09	K.Okada	A.Miyoshi	I.Fujioka	Refer to Revision Record on page 2.	DRAW No.	P1PA03540-B0XX/6	Page	245 / 257	
07	Nov.12, 08	K.Okada	T.Anzai	I.Fujioka	Refer to Revision Record on page 2.					CUST.
06	Mar.10, 08	K.Okada	T.Anzai	I.Fujioka	Refer to Revision Record on page 2.					
Rev.	DATE	DESIGN	CHECK	APPR.	DESCRIPTION	PFU LIMITED				
Design	July 27, 2007	K.Okada	CHECK	K.Okada		APPR.	T.Anzai			

- Printed character strings

Specify the character strings to be printed. (43 characters at maximum)
 You can print out the following character strings by the direct input.
 Alphabet: A~Z, a~z
 Numbers: 0, 1~9
 Signals: !"#%&'()*+,-./:;<=>@[¥]^_`{|}~
 Others: (Space)
 (If the space is inserted at the beginning of sentence, the space is ignored.)

IN addition, the following definitions can be used. These definitions can also be selected from the menu displayed by clicking 

- %YYYY: Prints the scanned year by the Christian year (4 digits)
- %YYY: Prints the scanned year by the Japanese year (Heisei)
- %YY: Prints the scanned year by the last two digits of the Christian year
- %MMM: Prints the scanned month in English abbreviation. "JAN" is printed in January, "FEB" in February, and so on.
- %MM: Prints the scanned month in 2 digits. If the month is one digit, "0" is added to the left digit. "01" is printed in January and "12" in December.
- %M: Prints the scanned month in the required minimum number of digits. "1" is printed in January and "12" in December.
- %DD: Prints the scanned date in 2 digits. If the date is one digit, "0" is added to the left digit. "03" is printed in the 3rd, and "26" in the 26th.
- %D: Prints the scanned date in the required minimum number of digits. "3" is printed in the 3rd, and "26" in the 26th.
- %HH: Prints the scanned time (hour) in 2 digits on a 24-hour basis. If the hour is one digit, "0" is added to the left digit. "08" is printed at 8 o'clock in the morning, and "14" at 2 o'clock afternoon.
- %H: Prints the scanned time (hour) in the required minimum number of digits on a 24-hour basis. "8" is printed at 8 o'clock in the morning, and "14" at 2 o'clock afternoon.
- %NN: Prints the scanned time (minute) in 2 digits. If the minute is one digit, "0" is added to the left digit. "02" is printed at 8:02, and "48" at 2:48.
- %N: Prints the scanned time (minute) in the required minimum number of digits. "2" is printed at 8:02, and "48" at 2:48.
- %0Nud: Prints the counter value which increases and decreases on every page in N digits.
 Specifiable counter digits are 5 and 8 digits and they are described as "%05ud" and "%08ud" respectively.
 You can specify the initial counter value, how to increase and decrease, etc. in the "Counter" described previously.
This specification is available only at the end of the printing character column.

						TITLE	fi-6140/fi-6240/fi-6130/fi-6230/fi-614PR Maintenance Manual		
08	July 27, 09	K.Okada	A.Miyoshi	I.Fujioka	Refer to Revision Record on page 2.	DRAW No.	P1PA03540-B0XX/6	CUST.	
07	Nov.12, 08	K.Okada	T.Anzai	I.Fujioka	Refer to Revision Record on page 2.				
06	Mar.10, 08	K.Okada	T.Anzai	I.Fujioka	Refer to Revision Record on page 2.				
Rev.	DATE	DESIGN	CHECK	APPR.	DESCRIPTION	PFU LIMITED		Page	246 / 257
Design	July 27, 2007	K.Okada	CHECK	K.Okada		APPR.	T.Anzai		

8-8-4 Removing Jammed Documents

Remove jammed documents as follows:

Do not forcefully pull out the jammed documents.

1. Remove the documents from the ADF paper chute (Chuter Unit).
2. Holding the right side of the Print section, pull it open by turning it towards you.

To open the ADF, first open the Print section before proceeding.

3. Open the ADF by pulling it back gently.

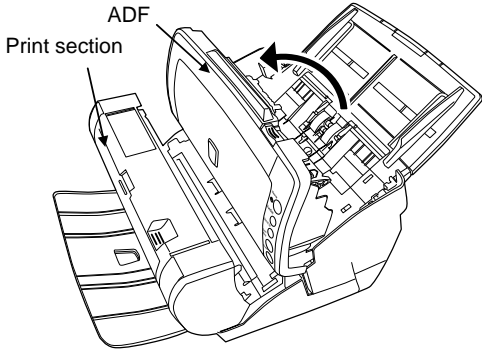
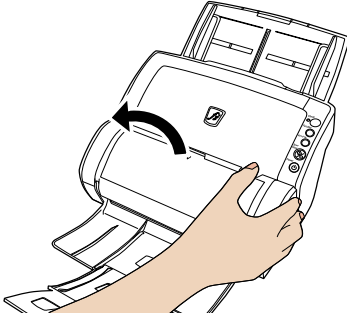

4. Carefully remove all the jammed documents.
5. Close the ADF.
6. Close the Print section.

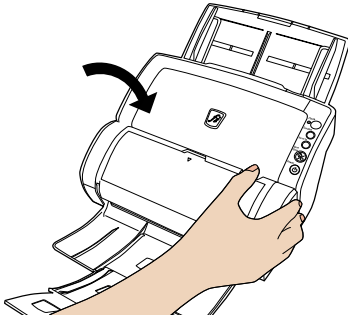

To close the Print section, be sure that the ADF is closed first before closing the Print section.

- Be careful not to pinch your fingers.
- Do not move the Imprinter or scanner while printing.
- When not using the Imprinter for a long period, remove the print cartridge from the Imprinter and store it.
- Each time the Imprinter is turned ON, some ink is initially consumed.
- Do not move the scanner with the Imprinter already installed. The Imprinter may become damaged.

						TITLE	fi-6140/fi-6240/fi-6130/fi-6230/fi-614PR Maintenance Manual		
08	July 27, 09	K.Okada	A.Miyoshi	I.Fujioka	Refer to Revision Record on page 2.	DRAW No.	P1PA03540-B0XX/6	CUST.	
07	Nov.12, 08	K.Okada	T.Anzai	I.Fujioka	Refer to Revision Record on page 2.				
06	Mar.10, 08	K.Okada	T.Anzai	I.Fujioka	Refer to Revision Record on page 2.				
Rev.	DATE	DESIGN	CHECK	APPR.	DESCRIPTION	PFU LIMITED		Page	247 / 257
Design	July 27, 2007	K.Okada	CHECK	K.Okada		APPR.	T.Anzai		

8-9 Cleaning and Consumables

8-9-1 Cleaning the Print Cartridge

Poor quality prints may occur due to blocked ink emission holes in the nozzle plate of the print cartridge. Leaving the Imprinter unused for a long period of time can also cause the ink emission holes to become blocked. When these holes are blocked, clean the nozzle plate.

For cleaning, use a dry lint-free cloth (Do NOT use tissue), and gently wipe any dirt and stains off the nozzle plate.

1. Press the  button to turn off the scanner.
2. Remove the print cartridge (Refer to Section 8-9-4).

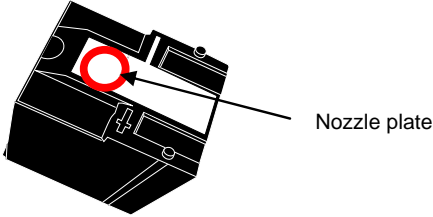

When cleaning, be careful not to touch directly by hand the Nozzle plate or any of the contact parts on the cartridge.

3. Gently wipe any dirt and stains on the nozzle plate.

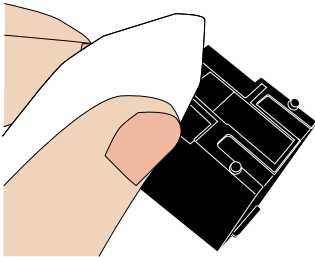

4. Make sure that all dirt and stains are removed, before installing the print cartridge. (Refer to Section 8-9-4).

When installing or replacing the print cartridge, be careful not to insert it out place.

						TITLE	fi-6140/fi-6240/fi-6130/fi-6230/fi-614PR Maintenance Manual		
08	July 27, 09	K.Okada	A.Miyoshi	I.Fujioka	Refer to Revision Record on page 2.	DRAW No.	P1PA03540-B0XX/6	CUST.	
07	Nov.12, 08	K.Okada	T.Anzai	I.Fujioka	Refer to Revision Record on page 2.				
06	Mar.10, 08	K.Okada	T.Anzai	I.Fujioka	Refer to Revision Record on page 2.				
Rev.	DATE	DESIGN	CHECK	APPR.	DESCRIPTION	PFU LIMITED		Page	248 / 257
Design	July 27, 2007	K.Okada	CHECK	K.Okada		APPR.	T.Anzai		

8-9-2 Cleaning the Imprinter

After frequent use, the waste ink will begin to accumulate on the base surface of the Print Cartridge Holder, which can soil printouts. Always maintain the base surface clean.

To assure high quality print outs and long use of the Imprinter, adopt a daily maintenance procedure as given below.

- When cleaning, wipe off gently all dust and ink on the base surface of the holder.
- If the ink has dried, wipe it lightly with a water-moistened cloth.

1. Press the  button to turn off the scanner.
2. Open the print cartridge. (Refer to Section 8-9-4).
3. Open the Print section.
4. Wipe off any dirt or dust on the base surface of the Print Cartridge Holder with a lint-free cloth.

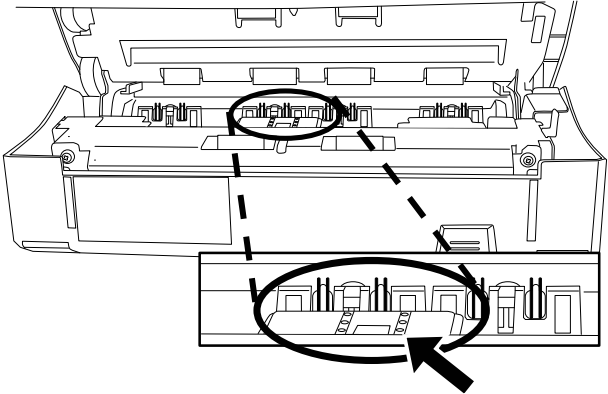

When cleaning, be careful not to touch the metal wheels located behind the upper rollers on the Print section.

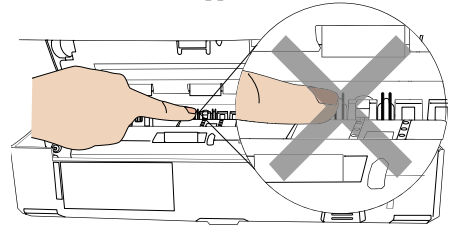

5. Check that the dirt is wiped off, and then close the Print section.
6. Reinstall the print cartridge and close the Print Cartridge Cover (Refer to Section 8-9-4).

						TITLE	fi-6140/fi-6240/fi-6130/fi-6230/fi-614PR Maintenance Manual		
08	July 27, 09	K.Okada	A.Miyoshi	I.Fujioka	Refer to Revision Record on page 2.	DRAW No.	P1PA03540-B0XX/6	CUST.	
07	Nov.12, 08	K.Okada	T.Anzai	I.Fujioka	Refer to Revision Record on page 2.				
06	Mar.10, 08	K.Okada	T.Anzai	I.Fujioka	Refer to Revision Record on page 2.				
Rev.	DATE	DESIGN	CHECK	APPR.	DESCRIPTION	PFU LIMITED		Page	249 / 257
Design	July 27, 2007	K.Okada	CHECK	K.Okada		APPR.	T.Anzai		

8-9-3 Cleaning the Imprinter Rollers

When ink or dust from paper is stuck on the feed roller surfaces, documents may not be fed smoothly. To prevent feed problems, clean the roller surfaces regularly.

Recommended cleaning cycle is every 1,000 sheets. The actual cleaning cycle may be shorter depending on usage and documents.

1. Open the Print section.

2. Clean the six rubber rollers.

The rollers are located as indicated on the right.

Wipe off any dirt or dust on the roller surface with a lint-free cloth moistened with cleaning fluid (ethyl alcohol).

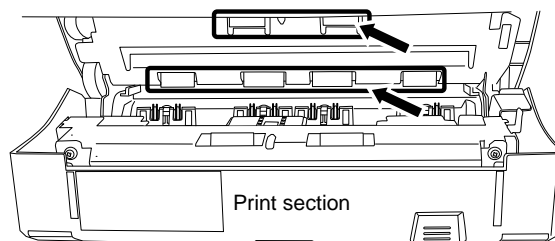

It may take long before the cleaner vaporizes if a large quantity is used. Wipe off the cleaner completely with a soft lint-free cloth to leave no residue on the surface of the cleaned parts.

To clean the entire surface of each roller, rotate it by holding down both the **Scan/Stop** and **Send to** buttons on the Operator Panel of the scanner by the number of times required to make a full turn.

When cleaning, be careful not to touch the metal wheels located behind the upper rollers on the Print section.

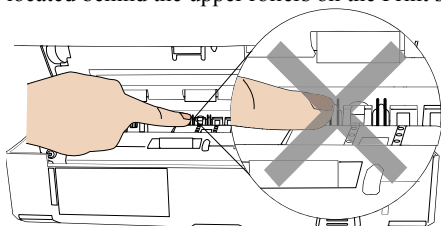

3. Clean the two plastic rollers (black).

The rollers are located inside the Print section as indicated below.

Rotate the rollers with your fingers gently and wipe off any dirt or dust from the roller surface with a lint-free cloth moistened with cleaning fluid (ethyl alcohol).

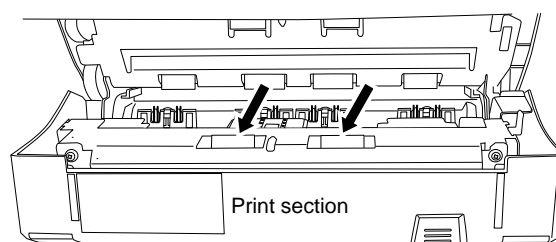

4. Confirm that all dirt and dust have been removed from the rollers. Close the Print section.

						TITLE	fi-6140/fi-6240/fi-6130/fi-6230/fi-614PR Maintenance Manual		
08	July 27, 09	K.Okada	A.Miyoshi	I.Fujioka	Refer to Revision Record on page 2.	DRAW	P1PA03540-B0XX/6	CUST.	
07	Nov.12, 08	K.Okada	T.Anzai	I.Fujioka	Refer to Revision Record on page 2.	No.			
06	Mar.10, 08	K.Okada	T.Anzai	I.Fujioka	Refer to Revision Record on page 2.				
Rev.	DATE	DESIGN	CHECK	APPR.	DESCRIPTION	PFU LIMITED		Page	250 / 257
Design	July 27, 2007	K.Okada	CHECK	K.Okada		APPR.	T.Anzai		

8-9-4 Replacing the Print Cartridge

When the message shown on the right appears, replace the print cartridge as soon as possible.

- If you continue to print without replacing the cartridge, your print output will be faded.
- When installing or replacing the print cartridge, be careful not to insert it out of place.

Refer to Section 8-1-1 for the specification of the Print cartridge.

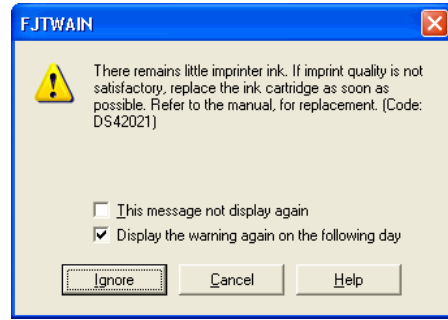

Example

1. Press the  button to turn off the scanner.
2. Open the Print Cartridge Cover by grasping its center and turning it towards you, as shown on the right.
3. Open the Print Cartridge Holder by slightly pinching and lifting up its locking lever with your fingers as shown below.

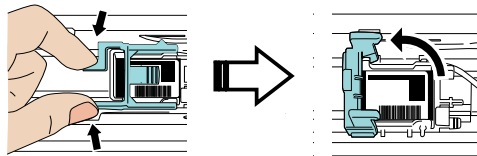
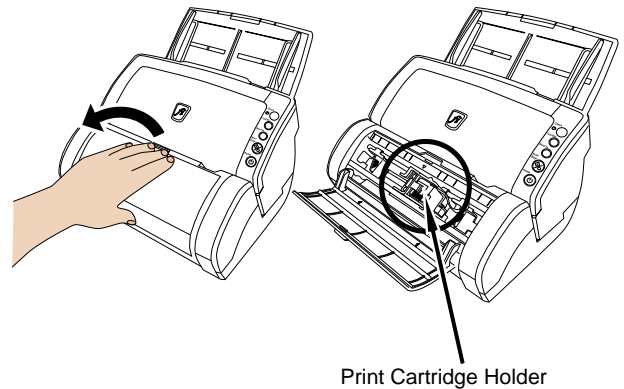

4. Remove the old print cartridge from the Print Cartridge Holder as shown on the right.
5. Take the new print cartridge out of its pouch and detach the protection tape from the Print cartridge.

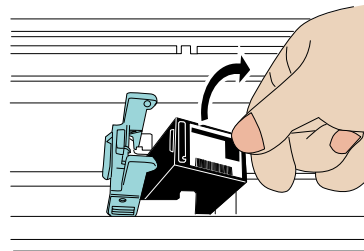

Do not touch the metal part of the cartridge nor put the tape back on again.

6. Place the print cartridge into the holder with its tab pointing to the right.

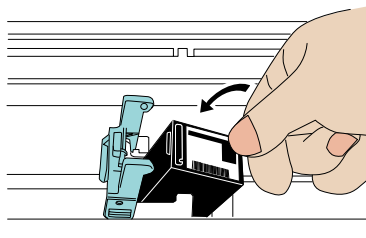

Be careful not to let the print cartridge touch or catch onto the print circuit film.

						TITLE	fi-6140/fi-6240/fi-6130/fi-6230/fi-614PR Maintenance Manual		
08	July 27, 09	K.Okada	A.Miyoshi	I.Fujioka	Refer to Revision Record on page 2.	DRAW	P1PA03540-B0XX/6	CUST.	
07	Nov.12, 08	K.Okada	T.Anzai	I.Fujioka	Refer to Revision Record on page 2.	No.			
06	Mar.10, 08	K.Okada	T.Anzai	I.Fujioka	Refer to Revision Record on page 2.				
Rev.	DATE	DESIGN	CHECK	APPR.	DESCRIPTION	PFU LIMITED		Page	251 / 257
Design	July 27, 2007	K.Okada	CHECK	K.Okada		APPR.	T.Anzai		

7. Lower the closing lever of the Print Cartridge Holder until it locks in and fixes the cartridge in place.

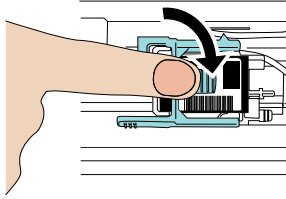

8. Position the Print Cartridge Holder along where the document will pass through.

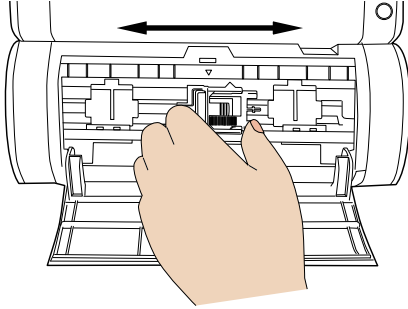

Printing too close to a document's edge can leave little or no room for further printing. Be sure to position the print cartridge to have enough space.

9. Close the Print Cartridge Cover.

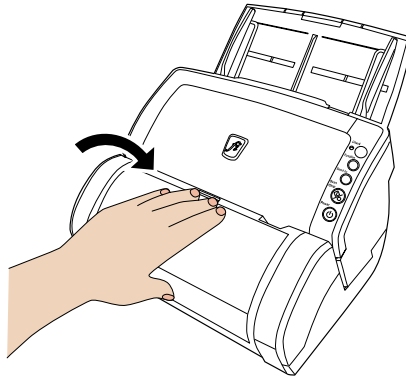

10. Turn on the scanner.

11. Reset the Ink Remaining Counter as follows:

You must reset the Remaining ink counter whenever you replace the print cartridge.

- 1) On the [Start] menu, select [Control Panel].
- 2) Select [Scanners and Cameras].
- 3) On the fi-6130/fi-6140 Scanner icon, right-click and select [Properties] (for Windows XP), or double-click the icon (for Windows 2000, Windows Vista).
- 4) Select [Device Set] tab.
- 5) Click the [Clear] button on [Remaining ink].
- 6) Click [OK] button.
- 7) The confirmation window will be displayed. Click [OK] button.

=>Remaining ink counter is reset to 100%.

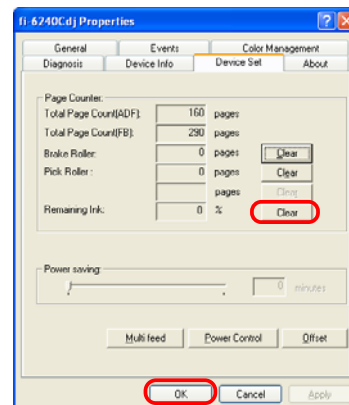

Rev.	DATE	DESIGN	CHECK	APPR.	DESCRIPTION	TITLE	fi-6140/fi-6240/fi-6130/fi-6230/fi-614PR Maintenance Manual	
08	July 27, 09	K.Okada	A.Miyoshi	I.Fujioka	Refer to Revision Record on page 2.	DRAW No.	P1PA03540-B0XX/6	CUST.
07	Nov.12, 08	K.Okada	T.Anzai	I.Fujioka	Refer to Revision Record on page 2.			
06	Mar.10, 08	K.Okada	T.Anzai	I.Fujioka	Refer to Revision Record on page 2.			
Design	July 27, 2007	K.Okada	CHECK	K.Okada	APPR.	T.Anzai	PFU LIMITED	Page 252 / 257

05

Appendix 1 Screws

The screws used for the device (scanner/ imprinter) are listed below.

Name in this manual	Description.	Specification	M	L
Screw A	PT SCREW	PA83952-5038	3	8

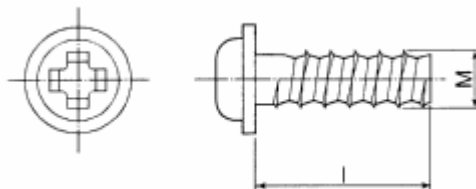

Name in this manual	Description.	Specification	M	L
Screw B		U30L-0010-0030#M3x5	3	5

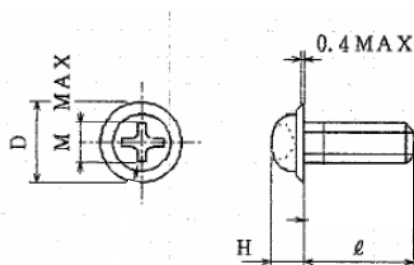

Name in this manual	Description.	Specification	M	L
Screw C	SCREW	RU6SW2N3-08121	3	8

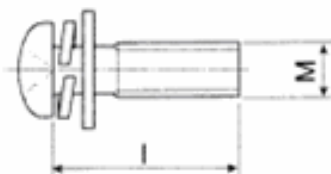

Name in this manual	Description.	Specification	M	L
Screw D	SCREW	RU6SNA3-06121	3	6

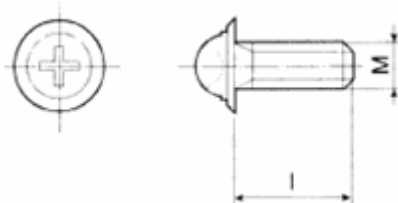

Rev.	DATE	DESIGN	CHECK	APPR.	DESCRIPTION	TITLE	CUST.	
08	July 27, 09	K.Okada	A.Miyoshi	I.Fujioka	Refer to Revision Record on page 2.	fi-6140/fi-6240/fi-6130/fi-6230/fi-614PR Maintenance Manual		
07	Nov.12, 08	K.Okada	T.Anzai	I.Fujioka	Refer to Revision Record on page 2.		DRAW No. P1PA03540-B0XX/6	
06	Mar.10, 08	K.Okada	T.Anzai	I.Fujioka	Refer to Revision Record on page 2.			
						PFU LIMITED	Page	253 / 257
Design	July 27, 2007	K.Okada	CHECK	K.Okada	APPR.	T.Anzai		

05

Name in this manual	Description.	Specification	M	L
Screw E		RU6SW2N2R5-08121	2.5	8

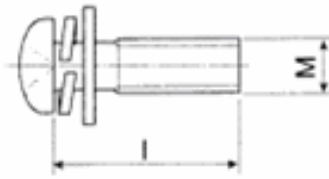

Name in this manual	Description.	Specification	M	L
Screw F	SCREW	CA98001-8785	4#40	5

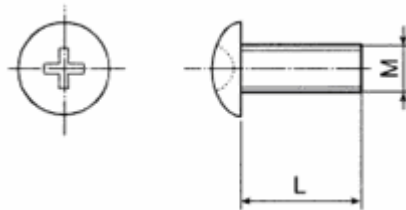

						TITLE	fi-6140/fi-6240/fi-6130/fi-6230/fi-614PR Maintenance Manual		
08	July 27, 09	K.Okada	A.Miyoshi	I.Fujioka	Refer to Revision Record on page 2.	DRAW No.	P1PA03540-B0XX/6	CUST.	
07	Nov.12, 08	K.Okada	T.Anzai	I.Fujioka	Refer to Revision Record on page 2.				
06	Mar.10, 08	K.Okada	T.Anzai	I.Fujioka	Refer to Revision Record on page 2.				
Rev.	DATE	DESIGN	CHECK	APPR.	DESCRIPTION	PFU LIMITED		Page	254 / 257
Design	July 27, 2007	K.Okada	CHECK	K.Okada		APPR.	T.Anzai		

Appendix 2 Emulation Mode

Emulation of the following scanners can be specified on this scanner.

Model name	Scanner that can be emulated
fi-6140	fi-4120C, fi-4120C2, fi-5120C
fi-6130	
fi-6240	fi-4220C, fi-4220C2, fi-5220C, fi-4340C
fi-6230	

To activate the Emulation function, scanner setting needs to be changed.
For the configuration method, see below.

1. With the ADF cover open and the Empty sensor status ON (by opening the cover all the way), press the **Power** button while pressing the **Function** button. (In this mode, the scanner interface with the host becomes off-line.)

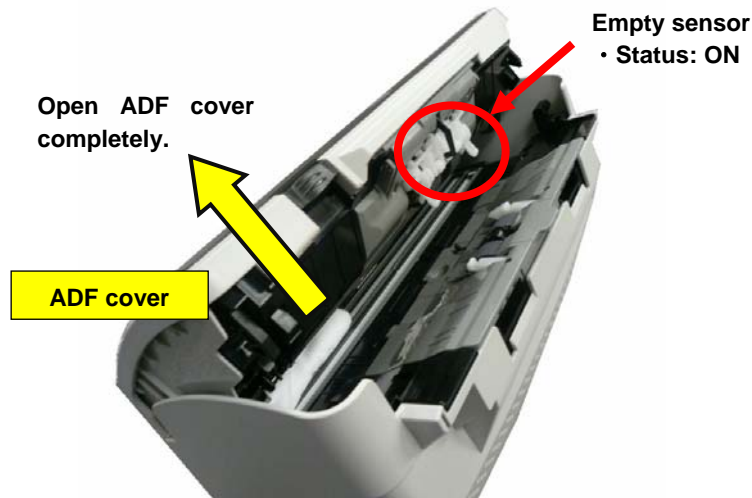

The following is the Function Number Display and the scanner status transition during scanner initialization after the power is turned ON in the procedure above.

Function No. Display	Scanner status
8	Initializing



Function No. Display	Scanner status
8	In Maintenance Mode

- When the scanner goes into the Maintenance Mode, let go of the **Function** button.



Function No. Display	Scanner status
8	In Emulation switch mode

- When the scanner goes into the Emulation switch mode, close the ADF cover.

						TITLE	fi-6140/fi-6240/fi-6130/fi-6230/fi-614PR Maintenance Manual		
08	July 27, 09	K.Okada	A.Miyoshi	I.Fujioka	Refer to Revision Record on page 2.	DRAW No.	P1PA03540-B0XX/6		CUST.
07	Nov.12, 08	K.Okada	T.Anzai	I.Fujioka	Refer to Revision Record on page 2.				
06	Mar.10, 08	K.Okada	T.Anzai	I.Fujioka	Refer to Revision Record on page 2.				
Rev.	DATE	DESIGN	CHECK	APPR.	DESCRIPTION	PFU LIMITED		Page	255 / 257
Design	July 27, 2007	K.Okada	CHECK	K.Okada		APPR.	T.Anzai		

2. During the Emulation switch mode, press the **Scan/Stop** button to display the current scanner setting.
- * If the Emulation mode is activated for the first time, the initial value (standard) “0” appears on the Function Number Display.
 - * Example) When fi-5120C (fi-5220C) is selected, “3” appears on the Function Number Display.
3. Pressing the **Function** button changes the displayed number. Press it several times until the number for the model you want your scanner to emulate appears.
- * Example) If your scanner is fi-6140, to emulate fi-4120C, press the **Function** button several times until “1” is displayed on the Function Number Display.
 - * Example) If the Function Number Display shows “1” on fi-6240, this scanner is configured as fi-4220C.

Function No. Display	Emulated model	Your scanner				Remarks
		fi-6140	fi-6130	fi-6240	fi-6230	
0	fi-6140	γ				Initial value (standard) Emulation mode invalid
	fi-6130		γ			
	fi-6240			γ		
	fi-6230				γ	
1	fi-4120C	γ	γ			Operates as USB1.1 specification (Full-Speed) when connected with the USB cable.
	fi-4220C			γ	γ	
2	fi-4120C2	γ	γ			
	fi-4220C2			γ	γ	
3	fi-5120C	γ	γ			
	fi-5220C			γ	γ	
4	fi-4340C			γ	γ	ADF scanner (fi-6140, fi-6130) cannot emulate fi-4340C.

4. Press the **Scan/Stop** button to display the selected scanner name (numbers) by turns.
- * The first “-” is a start mark. “SP” signifies “OFF: No display”. Switching interval is 0.5 second.

Emulation mode	How to display
fi-6140	“6140” is displayed as below repeatedly. “-” → “6” → “SP” → “1” → “SP” → “4” → “SP” → “0” → “SP”
fi-6130	“6130” is displayed as below repeatedly. “-” → “6” → “SP” → “1” → “SP” → “3” → “SP” → “0” → “SP”
fi-6240	“6240” is displayed as below repeatedly. “-” → “6” → “SP” → “2” → “SP” → “4” → “SP” → “0” → “SP”
fi-6230	“6230” is displayed as below repeatedly. “-” → “6” → “SP” → “2” → “SP” → “3” → “SP” → “0” → “SP”
fi-4120C	“4120” is displayed as below repeatedly. “-” → “4” → “SP” → “1” → “SP” → “2” → “SP” → “0” → “SP”
fi-4220C	“4220” is displayed as below repeatedly. “-” → “4” → “SP” → “2” → “SP” → “2” → “SP” → “0” → “SP”
fi-4120C2	“41202” is displayed as below repeatedly. “-” → “4” → “SP” → “1” → “SP” → “2” → “SP” → “0” → “SP” → “2” → “SP”
fi-4220C2	“42202” is displayed as below repeatedly. “-” → “4” → “SP” → “2” → “SP” → “2” → “SP” → “0” → “SP” → “2” → “SP”
fi-5120C	“5120” is displayed as below repeatedly. “-” → “5” → “SP” → “1” → “SP” → “2” → “SP” → “0” → “SP”
fi-5220C	“5220” is displayed as below repeatedly. “-” → “5” → “SP” → “2” → “SP” → “2” → “SP” → “0” → “SP”
fi-4340C	“4340” is displayed as below repeatedly. “-” → “4” → “SP” → “3” → “SP” → “4” → “SP” → “0” → “SP”

Rev.	DATE	DESIGN	CHECK	APPR.	DESCRIPTION	TITLE	DRAW No.		CUST.
08	July 27, 09	K.Okada	A.Miyoshi	I.Fujioka	Refer to Revision Record on page 2.	fi-6140/fi-6240/fi-6130/fi-6230/fi-614PR Maintenance Manual	P1PA03540-B0XX/6		
07	Nov.12, 08	K.Okada	T.Anzai	I.Fujioka	Refer to Revision Record on page 2.				
06	Mar.10, 08	K.Okada	T.Anzai	I.Fujioka	Refer to Revision Record on page 2.				
Design	July 27, 2007	K.Okada	CHECK	K.Okada		PFU LIMITED	Page	256 / 257	

5. If the scanner name (numbers) displayed on the Function Number Display is correct, press the **Function** button.
Pressing the **Function** button displays Screen E1 to ask whether to write the selected mode into EEPROM.

* To cancel the process, press the **Send to** button and return to the initial display of the Emulation mode.

[Screen E1]

Function No. Display	Power LED	Scanner status
8	ON	Blinks "o" (lower). Interval of blinking: 1.0 second (Switching interval of light ON and OFF is 0.5 second)

6. Writing to EEPROM.

Pressing the **Scan/Stop** + **Function** buttons writes the information of the scanner of which setting has been changed into EEPROM.

While the data is being written into EEPROM, Screen E2 appears.

When writing process is complete successfully, Screen E3 appears.

* To cancel the process, press the **Send to** button and return to the initial display of the Emulation mode.

[Screen E2]

Function No. Display	Scanner status
8	Displays "L" without blinking.

Data is being written into EEPROM.
No button is available.

- (1) When the process is terminated successfully:

[Screen E3]

Function No. Display	Scanner status
8	Displays "o" (upper) without blinking.

When data writing into EEPROM is complete successfully, Screen E3 appears.

- (2) When the process is terminated abnormally:

[Screen E4]

Function No. Display	Scanner status
8	Displays "c" (lower) without blinking.

If writing to EEPROM failed, the Screen E4 appears.

* When failed, start from step 1 again.

7. Restart the scanner.

If the process is terminated abnormally, turn off the power and back on again to restart the scanner.

Scanner configuration change for Emulation mode is complete now.

						TITLE	fi-6140/fi-6240/fi-6130/fi-6230/fi-614PR Maintenance Manual		
08	July 27, 09	K.Okada	A.Miyoshi	I.Fujioka	Refer to Revision Record on page 2.	DRAW No.	P1PA03540-B0XX/6	CUST.	
07	Nov.12, 08	K.Okada	T.Anzai	I.Fujioka	Refer to Revision Record on page 2.				
06	Mar.10, 08	K.Okada	T.Anzai	I.Fujioka	Refer to Revision Record on page 2.				
Rev.	DATE	DESIGN	CHECK	APPR.	DESCRIPTION	PFU LIMITED		Page	257 / 257
Design	July 27, 2007	K.Okada	CHECK	K.Okada		APPR.	T.Anzai		